



In situ conversion of methyl bromide to methyl iodide : a new technique for the measurement of atmospheric methyl bromide by GC-ECD
by Richard Allen Hughes

A thesis submitted in partial fulfillment of the requirements for the degree of Doctor of Philosophy in Chemistry
Montana State University
© Copyright by Richard Allen Hughes (1998)

Abstract:

Measurements of methyl bromide in the atmosphere have been complicated by the uncertain stability of methyl bromide in containers traditionally used for capture and storage of air samples. In addition, with atmospheric concentrations of methyl bromide at 10 pptv, current detection techniques require pre-concentration of large sample volumes. A method that provides a fast and simple measurement of methyl bromide in small air samples without pre-concentration would prove useful in many field applications. In this thesis, a technique is described which allows for the measurement of atmospheric concentrations of methyl bromide in 45-mL air samples. This is accomplished by in situ conversion of methyl bromide to the highly electron capture active methyl iodide with subsequent detection by electron capture detector. Conversion is accomplished by exposure of the methyl bromide to zinc iodide, which is contained in a heated in line column. Signal to noise ratios of better than 150:1 have been observed and reproducibility is +/-10% based on the data collected thus far. This technique should prove useful for the automated determination of methyl bromide in field applications.

IN SITU CONVERSION OF METHYL BROMIDE TO METHYL IODIDE: A NEW
TECHNIQUE FOR THE MEASUREMENT OF ATMOSPHERIC METHYL
BROMIDE BY GC-ECD

by

Richard Allen Hughes

A thesis submitted in partial fulfillment
of the requirements for the degree

of

Doctor of Philosophy

in

Chemistry

MONTANA STATE UNIVERSITY
Bozeman, Montana

August 1998

D378
H8745

APPROVAL

of a thesis submitted by

Richard Allen Hughes

This thesis has been read by each member of the thesis committee and has been found to be satisfactory regarding content, English usage, format, citations, bibliographic style, and consistency, and is ready for submission to the College of Graduate Studies.

8/25/98
Date

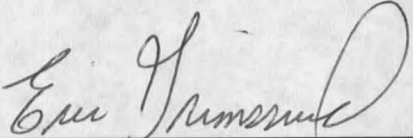
Eric P. Grimsrud
Chairperson, Graduate Committee

Approved for the Department of Chemistry

8/26/98
Date

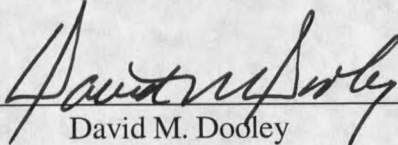
David M. Dooley
Head, Department of Chemistry

Approved for the College of Graduate Studies

8/27/98
Date

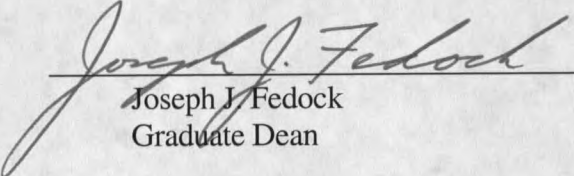
Joseph J. Fedock
Graduate Dean

STATEMENT OF PERMISSION TO USE

In presenting this thesis in partial fulfillment of the requirements for a doctoral degree at Montana State University-Bozeman, I agree that the Library shall make it available to borrowers under rules of the Library. I further agree that copying of this thesis is allowable only for scholarly purposes, consistent with "fair use" as prescribed in the U.S. Copyright Law. Requests for extensive copying or reproduction of this thesis should be referred to University Microfilms International, 300 North Zeeb Road, Ann Arbor, Michigan 48106, to whom I have granted "the exclusive right to reproduce and distribute my dissertation for sale in and from microform, along with the non-exclusive right to reproduce and distribute my abstract in any format in whole or in part."

Signature *Paul A. Hughes*
Date *8/20/98*

... but we rejoice in our sufferings, because we know that suffering produces perseverance;
perseverance, character; and character, hope...

Romans 5:3-4 (NIV)

To Tammy

Because without her great abilities as a wife, a mother and a friend, I would not have made it this far. She has been my inspiration!

TABLE OF CONTENTS

TABLE OF CONTENTS	vi
LIST OF TABLES	viii
LIST OF FIGURES	ix
ABSTRACT	xi
INTRODUCTION.....	1
Current Understanding of Stratospheric Ozone	1
The "Ozone Hole"	4
Ozone Depletion Chemistry	6
Atmospheric Bromine	8
Sources of Bromine in the Atmosphere	9
Troposphere.....	10
Stratosphere.....	10
Methyl Bromide	12
Anthropogenic Methyl Bromide	13
Natural Methyl Bromide	15
Global Budget of Methyl Bromide.....	16
Consequences of Anthropogenic Methyl Bromide	16
Current Methods of Detecting Methyl Bromide	17
STATEMENT OF PROBLEM	19
Motivation for Continued Investigation of Atmospheric Methyl Bromide	19
EXPERIMENTAL	21
In Situ Conversion of Methyl Bromide to Methyl Iodide.....	21
Instrument Design	21
Metal Iodide Conversion Columns	23
Metal Iodide/Phase Transfer Catalyst Conversion Columns	24
Sample Makeup.....	25
Evaluation of Conversion Column Efficiency	26

Investigation of the Conversion Products of Selected Halogenated Organic Compounds	27
Instrument Design and Conversion Evaluation.....	27
Determination of Methyl Bromide in Whole Air.....	29
Instrument Design	29
Sample Preparation, Collection and Testing.....	33
RESULTS AND DISCUSSION	35
In Situ Conversion of Methyl Bromide to Methyl Iodide.....	35
Interconversion of Alkyl Halides	35
Electron Capture Processes Involving Methyl Iodide.....	36
Detection of Converted Methyl Bromide by Electron Capture GC.....	37
Conversion Efficiencies of Metal Iodide Salts.....	39
Phase Transfer Catalyst Experiments.....	40
Investigation of Conversion of Halogenated Organic Compounds to Iodinated Products.....	44
Conversion of Selected Halogenated Organic Compounds by Zinc Iodide.....	44
Optimization and Characterization of Conversion Column.....	49
Effect of Conversion Column Temperature on Conversion Efficiencies.....	52
Effect of Conversion Column Configuration on Conversion Efficiency	54
Effect of Carrier Gas Flow Rate on Conversion Efficiency.....	55
Concentration Effects on Conversion Efficiency.....	57
Determination of Potential Product Loss or Degradation	57
Determination of Methyl Bromide in Whole Air.....	59
Study of Tritium ECD and Electrometer Behavior.....	64
Sample Size.....	71
Comparison of ^{63}Ni and ^3H ECD Detectors.....	73
Final Optimization of Chromatographic Parameters	78
Determination of Peaks of Atmospheric Significance	80
Conditions for Optimum Response.....	83
Reproducibility and Quantitation.....	83
Reproducibility of the Conversion of Methyl Bromide to Methyl Iodide in Whole Air.....	84
Verification and Calibration.....	86
CONCLUSION.....	90
LITERATURE CITED	94

LIST OF TABLES

Table 1. Metal iodide salts used to facilitate the conversion of alkyl bromides to alkyl halides.	23
Table 2. Phase transfer catalyst and metal iodide salt mixtures used to promote low temperature conversion of alkyl bromides to alkyl iodides.	25
Table 3. Thirty five alkyl halides that were tested for conversion to alkyl iodides with conversion column temperatures and concentration of alkyl halide tested.	28
Table 4. Relative conversion efficiencies of methyl chloride and methyl bromide to methyl iodide by 20 different metal iodide salts. Values are normalized to the conversion of methyl bromide by zinc iodide at 150°C.....	41
Table 5. Conversion efficiencies, (%), of methyl bromide and methyl chloride to methyl iodide by phase transfer catalyst/metal iodide columns.	42
Table 6. Percent conversion of alkyl halides upon exposure to zinc iodide.	46
Table 7. Percent conversion efficiency of methyl bromide to methyl iodide as a function of concentration.	58
Table 8. Instrumental conditions for optimum conversion of atmospheric methyl bromide to methyl iodide with subsequent separation from atmospheric components	83

LIST OF FIGURES

Figure 1. Schematic of instrument used to investigate the in situ conversion of methyl bromide to methyl iodide using a variety of metal iodide salts.	22
Figure 2. Schematic of instrument used to investigate the detection of methyl bromide in small volume whole air samples.	30
Figure 3. Schematic of a home built tritium ECD.	32
Figure 4. Schematic of heater block for tritium ECD.	32
Figure 5. Chromatograms for the conversion of methyl bromide to methyl iodide utilizing a sodium iodide column at 150°C. (A) 1-ppm sample of methyl bromide that was not exposed to the sodium iodide (B) 1-ppm sample of methyl bromide that was run through the in-line sodium iodide conversion column.	38
Figure 6. Chromatograms for 2-bromopropane. (A) Bypass mode, Through column mode with the reaction column at (B)150°C, (C) 100°C; (D) 50°C.	47
Figure 7. Chromatograms of 1,3-dibromopropane. (A) Bypass mode; (B) Through column mode with the reaction column at 150°C.	50
Figure 8. Chromatograms of 2,2-dibromopropane. (A) Bypass mode; Through column mode with reaction column at (B) 150°C; (C) 100°C.	51
Figure 9. Chromatograms for 10 ppm samples of methyl bromide that were introduced into the instrument, which was in through column mode, with the conversion column at 50°C, 75°C, 100°C, 125°C and 150°C. (A) Unconverted methyl bromide; (B) Methyl Iodide Product.	53
Figure 10. Chromatograms for the conversion of (A)methyl chloride and (B)methyl bromide to methyl iodide for carrier gas flow rates of 51, 47, 35, 30 and 25 ml/min.	56
Figure 11. Chromatogram of whole air with a methyl bromide spike in bypass mode and through column mode utilizing the GS-Q capillary column.(A) Methyl iodide peak due to conversion of methyl chloride; (B) Methyl iodide peak due to conversion of methyl bromide.	63
Figure 12. Plot of tritium ECD cell response to methyl iodide and standing current vs. ECD anode pin diameter.	65

Figure 13. Graph of tritium ECD response to methyl iodide vs. ECD anode pin position laterally within the cell..... 67

Figure 14. Plot of tritium ECD response to methyl iodide and ECD standing current and vs. ECD pulse period..... 68

Figure 15. Plot of tritium ECD response to methyl iodide vs. ECD cell temperature..... 70

Figure 16. Plot of tritium ECD cell response to methyl iodide vs. temperature, with and without the addition of wet nitrogen makeup gas. 72

Figure 17. Chromatograms of methyl iodide product response in whole air vs sample size for 5, 20 and 45 ml sample sizes 74

Figure 18. Chromatograms of whole air on the (A) 100°C tritium detector with wet nitrogen makeup gas and the (B) 300°C ⁶³Ni detector with no makeup gas. Both chromatograms were run in through-column mode with the conversion column at 150°C..... 77

Figure 19. Chromatograms of whole air utilizing optimized conditions. (A) Bypass mode; (B) Through column mode..... 79

Figure 20. Chromatogram of whole air with some of the major peaks identified. 82

Figure 21. Methyl iodide product response vs. Sample Day. (□) Repeated testing of a sample taken in a 4-L stainless steel container, filled 4/28/98 at a rural location approximately 2.5 miles from Bozeman, MT ; (····) and (---) represent the mean and standard deviation for this data; (X) Separate indoor air samples taken in the lab by syringe; (Δ) Separate outdoor air samples taken by syringe on MSU campus (o) Separate outdoor air samples taken by syringe through a 3rd floor window, Gaines Hall MSU. 86

Figure 22. Plot of methyl iodide product response vs. concentration for 3 1-ml samples (139 ppm) that were successively added to a 9600-L volume of whole air. 89

ABSTRACT

Measurements of methyl bromide in the atmosphere have been complicated by the uncertain stability of methyl bromide in containers traditionally used for capture and storage of air samples. In addition, with atmospheric concentrations of methyl bromide at 10 pptv, current detection techniques require pre-concentration of large sample volumes. A method that provides a fast and simple measurement of methyl bromide in small air samples without pre-concentration would prove useful in many field applications. In this thesis, a technique is described which allows for the measurement of atmospheric concentrations of methyl bromide in 45-mL air samples. This is accomplished by in situ conversion of methyl bromide to the highly electron capture active methyl iodide with subsequent detection by electron capture detector. Conversion is accomplished by exposure of the methyl bromide to zinc iodide, which is contained in a heated in line column. Signal to noise ratios of better than 150:1 have been observed and reproducibility is +/-10% based on the data collected thus far. This technique should prove useful for the automated determination of methyl bromide in field applications.

INTRODUCTION

Current Understanding of Stratospheric Ozone

The earth is protected from much of the sun's UV-B radiation (290 nm-320 nm) and UV-C radiation (175 nm-290 nm) by a layer of ozone (O_3) in the stratosphere, which strongly absorbs in the 230 to 290nm region^{1,2}. This is critical to life on earth since short wavelength UV of less than 290 nm can damage DNA². Ozone is ubiquitous in the atmosphere, but its concentration reaches a maximum in the stratosphere between 19 and 23 km above the surface of the earth³.

A two-step process in the upper stratosphere naturally generates a majority of ozone². First, molecular oxygen is photodissociated by the sun's UV radiation (<230 nm).



This is then followed by a reaction of atomic oxygen with a molecule of oxygen to form ozone. There is a third body involved in the reaction, M, which absorbs the energy produced by this reaction. M is usually a molecule of nitrogen, oxygen or an aerosol particle.



These reactions are most prevalent near the equator due to the intensity of the sun.

Currents in the atmosphere distribute the ozone with the general motion being toward the poles.

Once formed, the ozone absorbs UV radiation, 230 to 290nm, which results in its destruction.



Ozone can be further destroyed by reaction with atomic oxygen to give two oxygen molecules.



This series of reactions was long thought to be the sole regulation mechanism for natural ozone and is often referred to as the Chapman mechanism⁴. However, it proved to be inadequate for explaining the steady state concentration of ozone in the stratosphere, which is lower than the mechanism suggests. It should be noted here that the stratosphere warms with altitude due in most part to the exothermicity of reaction (2) and (4).

There must, therefore, be other sinks of ozone to account for the extra loss not accounted for in the Chapman mechanism. Natural sinks for stratospheric ozone are, in fact, numerous. Only when these sinks are taken into account, does the mechanistic theory of equilibrium for this system explain the observed concentration. The major chemical pathways for destruction of ozone are a result of the catalytic interaction shown below².

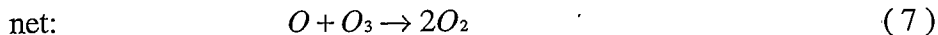

where $X = H, OH, NO, Cl$ or Br . The source of these radicals in a pristine stratosphere is from $H_2O, N_2O, CH_3Cl, CH_3Br$ and other naturally occurring halocarbons¹. These radicals are formed as a result of reactions with light, atomic oxygen or other radicals. The reactive species HO_x, NO_x, ClO_x and BrO_x , where $x = 1$ or 2 , produced in reaction (5) become the path through which each radical participates in the catalytic destruction of ozone. Note that the net effect of this cycle is the same as in (4) above.

These catalytic cycles are broken when the reactive compounds react with each other or other species to produce "reservoir" species, which act to control the rate of ozone destruction and to remove the radicals from the catalytic cycle and potentially the atmosphere. Reservoir species are more stable and are less likely to participate in ozone depleting reactions. Some of the major reactions that produce these species are:



Nitrogen analogs provide the bulk of the chain termination reactions. These nitrogen species are present in comparatively high concentrations, 10 ppb to 200 ppb, and in effect provide a supply of reactants with which the radicals can react.⁵ Many of these reactions also have fast reaction rates making their formation even more probable. In fact, at any one time only a few percent of the chlorine species exist in their active, ozone depleting, form. However, bromine compounds do not form reservoir species as readily and over 50% of inorganic bromine in the stratosphere resides in its active, BrO_x , form.⁵ The formation of reservoir species due to nitrogen compounds as well as the lack

of bromine containing reservoir species will become critical to understanding the unique chemistry that takes place in the stratosphere at the geographic poles, which will be discussed shortly.

The "Ozone Hole"

The material presented above represents the basic chemistry of ozone in the pristine stratosphere. In 1957, Dobson and others began taking routine measurements of total column ozone in the atmosphere over Antarctica.⁶ Total column ozone is measured by a spectrophotometer in Dobson units, which represents the vertical thickness in cm of ozone (reported as times 1000) in the atmosphere reduced to a layer of pure gas at 0°C and 760 mm Hg.⁶ Over the next two decades, periodic measurements of total column ozone made at various locations on the continent of Antarctica indicated that average ozone levels were 350 Dobson units with seasonal variations of +/- 75 units¹.

In the early 1970's, Roland and Molina⁷ put forth a theory about the potential of man-made halogenated compounds to effect the natural balance of ozone in the stratosphere. The source of these halogenated compounds was proposed to be from chlorofluorocarbons (Freons) and bromofluorocarbons (Halons). The specific chemistry involved will be discussed below. Prior to this point very little research had been conducted on the trace gas make up of the atmosphere and more specifically the stratosphere. There has since been, and continues to be, extensive study of atmospheric dynamics and chemistry at all altitudes.

Then in the early 1980s, it became very apparent that the levels of total column ozone were changing drastically over Antarctica each spring (September, October)⁸. By the middle 1980s, observations noted that total column ozone over the South Pole would decrease by as much as 50 % each spring. Other experiments measuring the vertical profile of ozone indicated that summer ozone concentrations reach a maximum at approximately 20 km and that the spring time decrease was mostly a result of an extreme loss of ozone at this altitude.^{9,10,11}

The extreme thinning of the ozone layer over Antarctica each spring has become known as the "ozone hole". Physically, the ozone hole is defined as the area where ozone levels drop to 220 DU or less¹². Depletion of 90% of the total column ozone has been recorded in portions of the hole and 100% depletion has been observed at altitudes from 14 to 19 km. The spring ozone hole has been observed regularly over the *entire* continent of Antarctica since the early 1980s. What is often overlooked is that Antarctica is quite large, approximately 13 million square kilometers (the U.S. has 9.3 million square kilometers). Data from 1992 and 1993 show the hole to encompass an area of over 24 million square kilometers.¹³ Calculations have indicated that springtime ozone loss over Antarctica represents a loss of up to 3% of the global ozone in a one to two month period.¹⁴ Measurements have indicated negative decadal trends in ozone over all areas of the globe with the exception of the tropics.^{5,15}

Ozone loss over the Arctic has been observed in the spring as well.^{16,17} Although the depletion is not as extensive, concern has been high due to the additive effects of another ozone sink and the relative proximity of the Arctic to major population centers

as compared to the Antarctic. Questions have been raised concerning the potential effects of significant stratospheric ozone depletion over metropolitan areas even if for short periods. Spring ozone loss within the Arctic vortex has been measured since the middle 1970s. In the early 80s measurements indicated that maximum total column ozone loss was 5 to 8%, which is within the expected annual variability.³ By the mid 90s that level had only changed slightly and, unlike its Antarctic counterpart, was still within expected annual variability.

As a result of the theories on the effects of halocarbons on ozone and subsequent confirmation through the formation of the spring time ozone hole and the measurements of decadal declines in ozone, Roland and Molina along with Crutzen, for his work on understanding atmospheric nitrogen chemistry, were awarded the 1995 Nobel Prize in Chemistry. Since this recognition, these theories have been widely accepted in the scientific communities, although some disagreement remains.¹⁸

Ozone Depletion Chemistry

The conditions that allow such severe ozone depletion to take place are unique to the geographic Polar Regions, although the severity in Antarctica is unrivaled. Discussion here will focus on the chemistry in the stratosphere over Antarctica with some discussion of the differences seen in the Arctic.

As winter develops in the Southern Hemisphere, a phenomenon known as the polar vortex forms as a result of strong westerly winds. The vortex causes a major portion of the Southern Hemisphere's stratosphere to become isolated from the rest of

the global stratosphere. The vortex is generally centered over the South Pole and can encompass latitudes to 50°S. Due to the lack of sunlight and the isolation of the air within the vortex from warmer, higher latitude air, temperatures within the vortex drop to below -80°C during the winter. At this low temperature, clouds of nitric acid trihydrate (NAT), sulfuric acid tetrahydrate (SAT) and water begin to form in the Antarctic stratosphere. These clouds, known as polar stratospheric clouds, remove the reactive nitrogen (NO_x) species from the atmosphere by direct physical adsorption. With this nitrogen unavailable, ClO and BrO concentrations can then rise to as high as 2 ppb and 20 ppt, respectively, due to their inability to form reservoir species. As discussed above, nitrogen compounds in the stratosphere are critical to the formation of these reservoir species and to the balance of ozone concentration in the stratosphere. Reactive nitrogen species are further removed from the atmosphere through heterogeneous reactions of remaining reservoir species on these cloud surfaces.

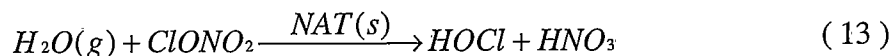
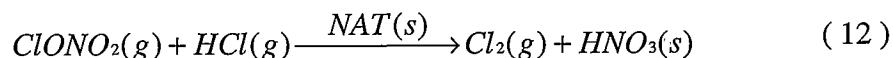

Sedimentation of these cloud particles is thought to worsen the problem because it essentially denitrifies the stratosphere. If sunlight were available, the NAT could photochemically produce NO_x's, however, sedimentation minimizes this turn around and allows the reactive chlorine to remain active. This buildup of active chlorine and bromine in the stratosphere takes place throughout the winter. When the spring sun returns to the polar region, the UV light quickly initiates reactions between this excess

reactive chlorine and bromine and ozone as shown in (5), (6) and (7). Ozone is destroyed at a rate of 2-4% per day during the height of the ozone depleting process.^{14,19}

As spring progresses, three factors control the end of the spring ozone hole. First, there is a depletion of available reactants due to the extreme loss of ozone. Second, as the stratosphere warms the PSCs sublime and reactive nitrogen becomes available by the photolysis of HNO_3 . The reservoir species then begin to form and break the chain reactions. As mentioned above there has been evidence of sedimentation of the NAT which minimized this pathway. Third, the vortex begins to break up, which allows mid-latitude air to once again mix with the polar air and replenish the ozone in the polar stratosphere and bring in a supply of reactive nitrogen compounds to reestablish the equilibrium.

The Arctic wintertime chemistry is similar except for two major factors. First, the winter time vortex is weaker and not as clearly defined.¹⁶ Second, the temperatures in the Arctic stratosphere do not get as low as they do in the Antarctic. The limited vortex allows for more mixing with mid-latitude air and therefore the isolated ozone loss is not observed. At these higher temperatures, PSCs do not form as readily and therefore heterogeneous chemistry plays a much more limited role. The warmer temperatures also support the existence of the reservoir species, which also limits the loss of ozone

Atmospheric Bromine

Up to this point three main factors concerning ozone have been covered. First, it has been shown that a few basic reactions drive the overall steady-state system, which

acts to regulate the amount of ozone in the stratosphere. Second, it was shown that under certain conditions severe perturbation of the ozone equilibrium could be seen. Third, it was suggested that bromine is at least a participant in the chemistry of stratospheric ozone. There are, however, many indications bromine actually plays a *major* role in the perturbation of atmospheric ozone levels that have been observed for the past 20 to 25 years.^{20,21,22} A brief overview, emphasizing the ozone/bromine related interactions, will show, in fact, that bromine plays a critical role in the ozone cycle and especially in the ozone depletion phenomenon. It is important to highlight what might otherwise be perceived as an insignificant contribution to the make-up of the atmosphere.

Sources of Bromine in the Atmosphere

Vertical profiles indicate that there is little change in the concentration from ground level to the tropopause of the most common alkyl bromides in the atmosphere. Most recent measurements show that the total organic bromine at the tropical tropopause (~12km) has been measured to be 17.4 +/- 0.9 ppt.²³ Of this, methyl bromide, which has both natural and anthropogenic sources, accounts for 54%. The specific sources of methyl bromide will be discussed in a later section. Most of the remainder of the organic bromine comes from Halons (38%), which are used as fire suppressants and are of entirely anthropogenic origin, dibromomethane (6%), bromochloromethane and dichlorobromomethane (0.8% combined) all are produced from natural sources. This low concentration of bromine-related compounds pales in comparison to the 3.5 ppb of chlorine containing species.²⁴ As will be demonstrated shortly, however, bromine not

only plays a critical role in the equilibrium of ozone in the atmosphere as discussed above but also the perturbation of atmospheric ozone.

Troposphere

Once released into the troposphere, the halocarbons mix rapidly and become relatively evenly distributed. In the troposphere, for those compounds with a C-H bond, the most common path of chemical destruction is reaction with the hydroxyl radical.²⁵

Using methyl bromide as an example:

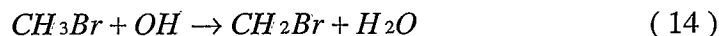

After formation of the radical, it subsequently reacts with a variety of other species, such as O₂, to produce water-soluble products, which then are rained out of the troposphere. Fully halogenated chemicals such as the Halons do not react with the hydroxyl radical, as shown in (14), and reach the stratosphere unchanged.⁵

Stratosphere

Once in the stratosphere, organic bromine is photolyzed or reacts with OH or O to produce free bromine. This bromine then reacts with a variety of species (OH, O, O₂, O₃, ClO, NO and NO₂) to produce a variety of inorganic bromides such as BrO, HOBr, HBr, BrCl and BrONO₂.⁵

The formation of the reservoir species BrONO₂, BrCl HOBr and HBr is much less favored than those of its chlorinated counterparts. As such, only about one-half of the inorganic bromine resides in these forms. The remainder of the bromine stays in the reactive forms, Br and BrO.^{26,27} Also, the brominated reservoir species are much more

photochemically active, which allows them to be converted to reactive bromine much more quickly than their chlorine counterparts.

Once formed, these inorganic bromides can react through a variety of pathways with ozone. Wofsy and Watson first recognized the role of bromine in stratospheric chemistry in 1975²¹ but their ideas were largely treated as a minor contender until 1980 when Yung²² expanded on their proposals. He showed that stratospheric bromine could play a major role in ozone depletion in two ways. First, he reiterated that bromide analogs themselves are effective ozone sinks through similar reactions as shown above.

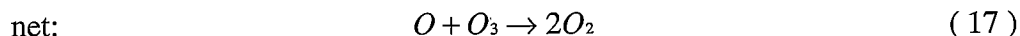
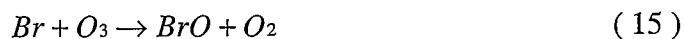

Second, he noted that the bromine analogs could react with ClO, NO₂ and HO₂ synergistically to remove ozone even more effectively. Yung indicated that the cycle shown below is one of the most important due to its regeneration of the chlorine and bromine radical.

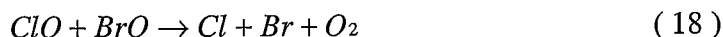

This regeneration process enables the bromine and chlorine to participate in more reactions with ozone than they might otherwise. It is this synergistic effect that makes this path so critical. Prior to this understanding, models of ozone depletion were not adequate to explain the losses being seen. When the bromine chemistry as discussed by Yung was taken into account, a significant increase in model accuracy was observed

when compared with field data. As a result of this understanding, it is now believed that bromine may be responsible, either directly or indirectly, for approximately 25% of the ozone loss in the stratosphere.^{3,5} However, during the unique conditions that bring about the ozone hole, bromine may be responsible for as much as 50% of the depletion of ozone. Utilizing the kinetics of the known bromine and chlorine containing reactions, it has been shown that bromine is 50 to 100 times more efficient than chlorine on a per atom basis at destroying ozone.²⁸

As mentioned above the sources of bromine in the atmosphere are both anthropogenic and natural. Because the Halons, which have not been made since 1993, are not reactive in the troposphere their life times are exceedingly long.²⁹ Even if emission from current feed stock were to cease today, their presence would be evident for many decades. However, methyl bromide, responsible for 54% of the organic bromine in the atmosphere, readily reacts in the troposphere. There are predictions that the elimination of anthropogenic sources of methyl bromide could have profound impact on the ozone hole in a very short time due to its reactivity in the troposphere and short tropospheric lifetime.²⁵

Methyl Bromide

Methyl bromide is unique among the brominated compounds that are prevalent in the atmosphere because it has both natural and anthropogenic origins. However, studies on the sources of methyl bromide are limited and there has been no definitive agreement regarding the output from all of the sources or even what the all of the sources are. This

section will focus on what is known about the sources of methyl bromide in an attempt to provide a clear understanding as to the implications regarding the depletion of ozone and as to the potential implications and applications of this project.

Anthropogenic Methyl Bromide

In the middle 1930s, methyl bromide was determined to be an excellent anti-fungal agent for horticulture produce.²⁵ Over the next thirty years, it was discovered that methyl bromide was also useful for structural fumigation and pest/disease fumigation in soil. The popularity of methyl bromide grew due to its effectiveness and its ability to replace several pesticides and herbicides. The effectiveness of methyl bromide has been unsurpassed by any single chemical or treatment process for control of pests and fungus. Unlike many other treatments, no observed pest tolerance toward methyl bromide has ever been detected. As a volatile gas, it is quick to dissipate after application. The only potential hazards to the consumer are consumption of inorganic bromides that were created as a product of the methylation process or by direct exposure to methyl bromide as a result of application processes. Consumption of inorganic bromides has been determined to be inconsequential. However, illness and death have been reported as a result of direct exposure to methyl bromide. Farm workers and residents living near fields where methyl bromide is applied are the most likely candidates for exposure. Since methyl bromide is a gas and because of the nature of the fumigation process, it has been estimated that up to 60% of the methyl bromide applied is released into the atmosphere and as such the potential for human exposure is high.³⁰ This figure is highly

variable as it is dependent on soil conditions, application technique, recovery technique and in situ destruction.

Atmospheric methyl bromide of anthropogenic origin has three main sources. These include industrial use and production, leaded gasoline and bio-mass burning. Industrial production is relatively well quantified in developed countries but production in undeveloped countries is difficult to monitor and of that which is produced, the determination of the amount released into the atmosphere is highly speculative. Today, worldwide industrial production of methyl bromide is approximately 76,000 tons annually. Of this amount, more than 70% is applied annually in the U.S. for agricultural soil fumigation, 24% is used for fumigation of structures, durables and perishables and 3% is used as chemical feedstock. Most recent numbers estimate that of this amount 41,000 tons are released annually. While recent developments in plastics may enable farmers to release less methyl bromide into the atmosphere, mechanical constraints dictate that loss to the atmosphere will never be eliminated.³⁰

Another anthropogenic source of methyl bromide comes as a result of a byproduct of the combustion of dibromoethane in leaded gasoline. Best estimates for methyl bromide's contribution to the atmosphere as a result of this process is 2500 tons annually +/- 100%. This value is highly speculative because of a lack of data regarding its use worldwide. Again, the measurements are poor and but levels should be dropping with fewer and fewer autos using leaded gasoline.³¹

Biomass burning is known to produce methyl bromide but quantitation of this effect has been difficult.^{32,33} Most methyl bromide from this source is thought to result

from the large fires in South America, Indonesia and other tropical zones where forests are burned to clear areas for agriculture. It has been estimated that natural fires account for less than 10% of the biomass that is burned annually.⁵ Best estimates indicate that fires contribute 25,000 tons of methyl bromide to the atmosphere annually. This value represents fires from both natural and anthropogenic causes.

Natural Methyl Bromide

The ocean is known to be both a source and a sink of methyl bromide. Recent measurements indicate that the ocean produces 56,000 tons/y of methyl bromide. However, the ocean also consumes about 77,000 tons/y of methyl bromide, mostly through hydrolysis. This data then indicates that the ocean is a net sink of 21,000 tons/y of methyl bromide.^{15, 34, 35} Again, quantitating such a value is difficult and associated uncertainties can have large implications with regard to the global budget of methyl bromide. All of these values depend on the validity of the rates for loss, which are also under constant scrutiny.

Soil has recently been realized as a viable sink for methyl bromide.^{36, 37} Calculations have indicated that the average annual loss to soil is on the order of 42,000 tons/y. The mechanism by which this loss takes place is proposed to be a result of biological oxidation. Proof of this is limited and the mechanisms up to this point are only speculative. Due to the wide variability of soil types and transport mechanisms, quantitating this sink has obvious hurdles to overcome.

Global Budget of Methyl Bromide

The currently accepted concentration of methyl bromide in the troposphere is 10 ppt +/- 1 ppt.¹⁵ Using this number the global burden, the amount in the atmosphere at any one time, is calculated to be 150,000 tons.³⁸ This causes a dilemma since the above numbers indicate that sources are only 60% of sinks. This would naturally lead to the conclusion that the concentration of methyl bromide in the atmosphere should either be declining or non-existent, which is not the case. Uncertainties in the sources and sinks as well as the non-uniformity of these sources and sinks make reconciling a global budget difficult. Most of the values presented above for natural sources and sinks have variability of at least 100%. Numbers for anthropogenic sources range in variability from 50% to 100%. Nevertheless, it has still been shown that methyl bromide has a significant anthropogenic element.

Consequences of Anthropogenic Methyl Bromide

Bromine, as mentioned, is responsible for 30 to 50% of the ozone depletion seen at the poles each spring both directly and indirectly. Also discussed is the fact that methyl bromide accounts for 55% of tropospheric bromine and is responsible for an equal portion of the stratospheric inorganic bromine. Since approximately 50% of methyl bromide is of anthropogenic origin, anthropogenic methyl bromide may be responsible for 8 - 12% of the Antarctic ozone hole. Research has shown that elimination of anthropogenic sources of methyl bromide could be equivalent to moving the phase out date of CFCs up 3 years.²⁵ Only through a better understanding of the

methyl bromide budget and sources will better estimates of the overall effects of methyl bromide be determined.

Current Methods of Detecting Methyl Bromide

The most common techniques used for the detection of halogenated compounds, and more specifically of concern here, methyl bromide, in air are the GC/ECD, the oxygen doped GC/ECD and GC/MS.^{23, 24, 37, 39, 40} All of these techniques are widely used and accepted in the field of atmospheric chemistry.

In order to detect atmospheric levels of methyl bromide it is often necessary to preconcentrate large volumes of sample with subsequent separation and detection by the GC/ECD or by GC/MS techniques mentioned above. Pre-concentration of samples is accomplished by the cryogenic focusing or adsorptive trapping of large sample volumes in a pre-column prior to chromatographic separation. Sample volumes are typically 0.5 to 2 L. Cryogenic methods rely on liquefied permanent gas temperatures to freeze out the constituents of a sample. After the desired volume is captured, the pre-column is heated, allowing the sample to enter the chromatographic column. Adsorbent trapping relies on the sample chemically adsorbing to a substrate packed into a pre-column. As before, once the desired volume of sample is trapped, the column is heated and the sample is desorbed and allowed to enter the chromatographic column. Detection by ECD can also be enhanced by using the oxygen-doped technique.⁴¹ Here, a known amount of oxygen is allowed to enter the ECD. The characteristics of the ECD chemistry are changed and signal enhancement is observed for selected compounds.

All of the methods mentioned have drawbacks when used for the determination of atmospheric methyl bromide on a routine basis. Cryofocusing samples requires the use of relatively large volumes of liquefied gases. This tends to be impractical in field applications. Cryofocusing might also require the collection of samples in the field for later analysis, which could lead to sample degradation, small sample numbers per location and elevated costs. Adsorbent traps rely on the chemical interaction of the species of interest and the adsorbent. If trapping is too efficient the compound of interest may be irreversibly trapped on the column. If the trapping is not efficient, the compound of interest might be unretained and lost out of the trap effluent. The Oxygen-doped ECD has limited versatility and tends to negatively effect the signal-to-noise ratio for response to methyl bromide. Methods, such as mass spectrometry, that do have good sensitivity are typically not field portable and as with cryofocusing discussed above, this then requires that the sample of interest be collected in a container and transported to the lab. Although sample containers exist that have been shown to not appreciably effect sample integrity, it becomes prohibitively expensive to collect a large number of samples.

STATEMENT OF PROBLEM

Motivation for Continued Investigation of Atmospheric Methyl Bromide

From the background that has been given on the basic chemistry of the atmosphere, it is clear that methyl bromide is a major contributor to processes involving atmospheric ozone. As seen above, the catalytic and synergistic effects of bromine on the destruction of ozone can be profound. Several groups and organizations have stated that the global levels of methyl bromide are still not completely characterized and that the sources and sinks as well as the source and sink mechanisms are not well understood.^{5,15,25,40} Determination of such values would allow for better estimates of atmospheric lifetime, ozone depletion potentials and overall atmospheric makeup.²⁵ Current techniques for the detection of methyl bromide rely on collecting samples in a container for later testing, thereby potentially affecting sample integrity, or pre-concentrating large sample volumes, which then requires equipment that may not be practical in many field settings. Investigation of the ability to increase the detectability of methyl bromide in small volume whole air samples is the primary goal of this thesis. A technique that relies on standard GC instrumentation but eliminates the need for pre-concentration would be of great interest to the atmospheric science community.

Watson and co-workers⁴² investigated a technique involving the in situ conversion of methyl chloride to methyl iodide, which is EC active, by exposure of the methyl chloride to a heated in-line sodium iodide column in order to enhance the detectability of

methyl chloride by electron capture detection. The first goal of this thesis is to investigate the potential conversion of methyl bromide to methyl iodide using a similar sodium iodide column along with electron capture detection. The second objective is to determine if this conversion reaction is restricted to sodium iodide or are other metal iodide salts also capable of facilitating the conversion of methyl bromide to methyl iodide. Third, can the conversion be made efficient enough without detrimentally effecting the ECD and yet still be able to enhance the response of methyl bromide? The fourth objective is to determine what effect the conversion column may have on the more abundant chlorocarbons that will be present in real air. Lastly, using the information from the first four steps, real air samples will be tested to determine if the improved detection of atmospheric concentrations of methyl bromide can be realized.

EXPERIMENTAL

In Situ Conversion of Methyl Bromide to Methyl Iodide

Instrument Design

A schematic of the instrument is shown in Figure 1. The base chromatograph was a Varian 3700. Standard grade nitrogen was used as the carrier gas at a flow rate of 35 ml/min except as noted in the section below detailing other system setups and optimization. Oxygen and water were removed from the carrier gas nitrogen by in-line Oxy-trap(Alltech) and Drierite / 5Å molecular sieve filters. Samples were introduced into the carrier gas stream via a 6-port valve, V1, (Carle Instruments, OK) fitted with a sample loop. The 2-ml sample loop was constructed of 3-mm o.d. stainless tubing. Two, three-meter 10% SF-96 on Chromasorb-W columns constructed of 3-mm o.d. stainless steel tubing were used for chromatographic separation. The chromatographic columns were used at ambient temperature. The first column provided initial separation of the sample prior to the metal iodide conversion column. The second column provided post conversion column separation of products and reactants that resulted from reactions within the metal iodide conversion column. The conversion column could be switched into or out of the flow path between the two chromatographic columns by a second 6-port valve, V2.(Valco Instruments). This valve allowed the effluent from the first chromatographic column to bypass, BP mode, the conversion column or be directed onto the conversion column, TC mode. A separate nitrogen source is used to maintain

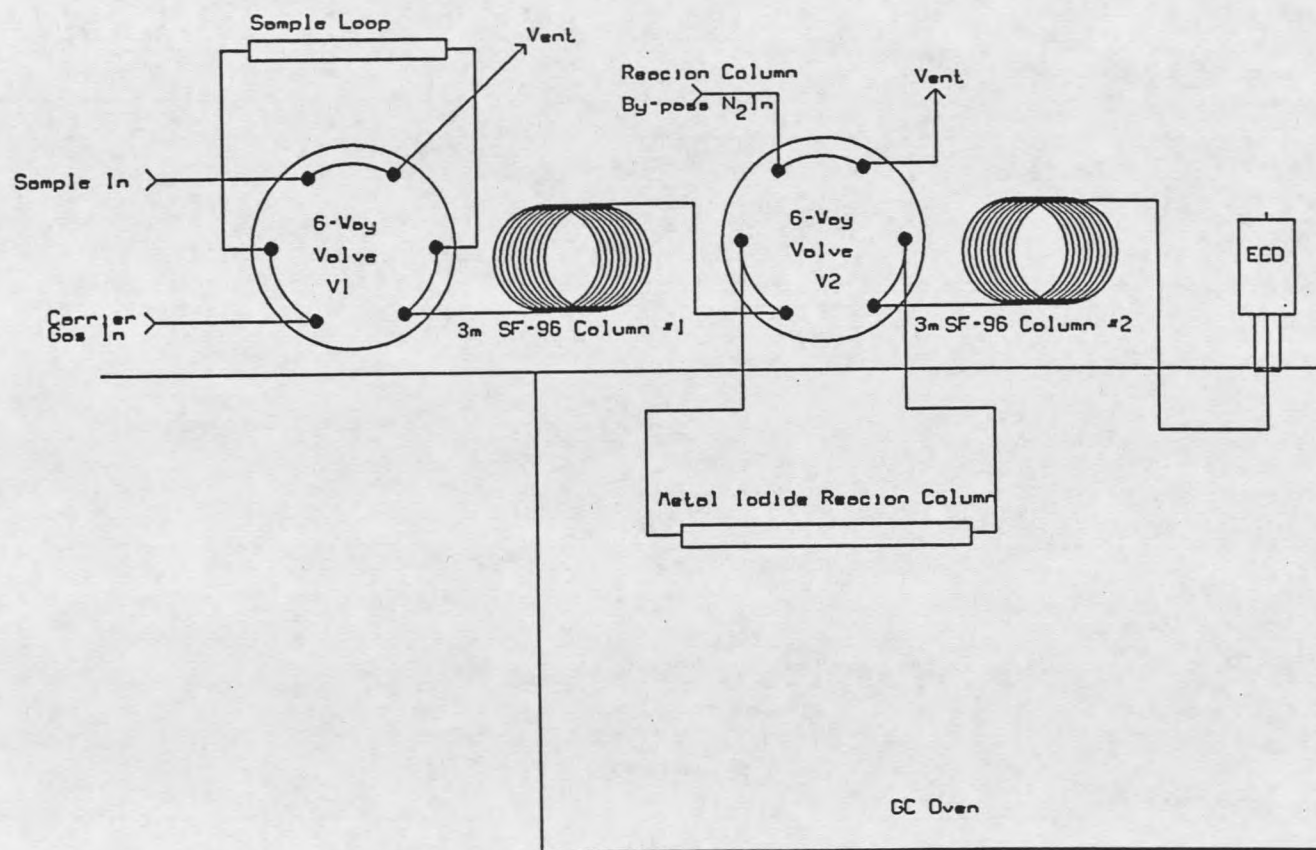

Figure 1. Schematic of instrument used to investigate the in situ conversion of methyl bromide to methyl iodide using a variety of metal iodide salts.

nitrogen flow through the conversion column when the option of bypassing the reaction column is utilized. The temperature of the conversion column was controlled by use of the Varian 3700 oven and associated controls. Effluent from the chromatographic columns was directed into an electron capture detector. The detector was operated at 250°C.

Metal Iodide Conversion Columns

Conversion columns were constructed of 6-mm o.d. copper or stainless steel tubing packed with a mixture of Chromasorb-W and metal iodide salt. A list of the metal iodide salts tested is given in Table 1. All chemicals were used as received.

Table 1. Metal iodide salts used to facilitate the conversion of alkyl bromides to alkyl halides.

AgI ₂	CsI	MnI ₂	RbI
BaI ₂	CuI	NaI	SnI ₂
BiI ₃	KI	NH ₄ I	SnI ₄
CaI ₂	LiI	NiI ₂	SrI ₂
CdI ₂	MgI ₂	PbI ₂	ZnI ₂
CoI ₂			

Conversion columns were prepared according to the following procedure. The metal iodide salt was ground to a fine powder using a mortar and pestle and then combined with an equal volume of Chromasorb-W in a graduated cylinder. The piece of tubing was plugged on one end with a small piece of glass wool. The mixture was then poured, with the aid of a funnel, into the other end of the tube with light tapping of the tube on the bench to ensure even filling and to minimize air pockets. The tube was filled to within 6 mm of the end of the tube. Typically, 1.5 – 2.0 g of the mixture was put into

each 15-cm length of 6-mm o.d. tubing. A glass wool plug was used to fill the rest of the tube. Ends of the column were fitted with Swagelok fittings to allow installation on to the instrument. All stages of column preparation were done in a fume hood except when using compounds with extreme air sensitivity. These columns were prepared in a nitrogen filled glove bag. Methodology for preparing conversion column materials, as described by Ooman,⁴⁶ where the metal iodide is dissolved in a solvent and mixed with the support followed by removal of the solvent under vacuum was attempted but results were poor. After each column was prepared, it was baked out at 250 °C for 24 to 72 hours under a flow of 30 ml/min nitrogen. After bakeout, the column was either installed or capped for future use. After installation the column was heated to 150°C and allowed to equilibrate for at least two hours.

Metal Iodide/Phase Transfer Catalyst Conversion Columns

These columns contained a mixture of phase transfer catalyst (PTC), metal iodide salt and support media. Support media was either Chromasorb-W (Alltech or Supelco) or silica gel. Table 2 shows the PTCs used in this study. Methodology for the preparation of the contents of PTC columns was followed as described in the literature.⁴³ This basically involved adding the three components mentioned above to a mixture of water/methanol (7/3) with stirring. After 10 minutes of stirring the water/methanol mixture was removed under aspirator vacuum using a rotary evaporator. The mixture was then baked in a 110°C oven overnight and subsequently stored in an airtight

Table 2. Phase transfer catalyst and metal iodide salt mixtures used to promote low temperature conversion of alkyl bromides to alkyl iodides.

Phase Transfer Catalyst	Metal Iodide Salt	Mixture in gram ratios of Support : Phase Transfer Catalyst : Metal Iodide Salt
Tetrabutylammonium Iodide	Potassium Iodide	Silica Gel:PTC:KI 5.58:0.48:3.94
Tetrabutylammonium Iodide	Zinc Iodide	Silica gel:PTC:ZnI ₂ 5.58:0.48:3.94
Tetrabutylammonium Iodide	Zinc Iodide	ChromasorbW:PTC:ZnI ₂ 2.65:0.48:3.94
Tetraethylammonium Iodide	Zinc Iodide	ChromasorbW:PTC:ZnI ₂ 3.6:0.50:6.24 Dry prep
Tetraethylammonium Iodide	Zinc Iodide	ChromasorbW:PTC:ZnI ₂ 4.0:0.50:6.24 Wet prep
Tetraethylphosphonium Iodide	Zinc Iodide	ChromasorbW:PTC:ZnI ₂ 4.0:0.50:5.82
Tetraphenylphosphonium Iodide	Zinc Iodide	ChromasorbW:PTC:ZnI ₂ 2.0:0.50:3.42
Tetrabutylammonium Iodide	Zinc Iodide	ChromasorbW:PTC:ZnI ₂ 2.67:0.48:3.96 Wet prep
Tetrabutylammonium Iodide	Lead Iodide	ChromasorbW:PTC:PbI ₂ 3.25:0.50:6.24
Tetrabutylphosphonium Iodide	Zinc Iodide	ChromasorbW:PTC:ZnI ₂ 4.15:0.50:2.72 Wet prep

container until needed. The columns themselves were then constructed as described previously.

Sample Makeup

Compounds used in this study were purchased from a variety of commercial vendors. All of the compounds purchased were used as received. Samples of each compound to be tested were made by standard dilution into airtight glass carboys, which were maintained at above-ambient pressure. Carboy volumes were either 20 L or 4.5 L.

Nitrogen was used as the diluent gas and was checked for the presence of electron capturing impurities prior to sample preparation. Initial dilution was performed by injecting a small aliquot of either a neat liquid (0.5 to 100 μ l) or gas (0.5 to 5 ml) into a carboy that was subsequently pressurized to between 1 and 10 psi, depending on the desired concentration. Subsequent dilution was performed by transferring a sample from this initial carboy using a 10 ml gas tight syringe for sample transfer and a second carboy, which was subsequently pressurized to between 1 and 10psi. On occasion this second carboy was used to make a third carboy of even lower concentration. However, final dilutions and sample transfer were usually accomplished using a 100-ml or a 250-ml gas-tight syringe equipped with a Hamilton HV Plug Valve.

Evaluation of Conversion Column Efficiency

After construction, conditioning and installation of a metal-iodide conversion column, samples of methyl bromide or methyl chloride were introduced into the system via the sampling loop. Each metal iodide listed in Table 1 was evaluated for its efficiency of converting 1-ppm methyl bromide and 1-ppm methyl chloride to methyl iodide. The reaction column temperature was varied from 50°C to 150°C in 25°C increments for each metal iodide salt. After adjusting the column temperature, the system was allowed to equilibrate for 1 hour. A strip-chart recorder was used to monitor the output signal of the ECD. This procedure was repeated for each metal iodide. Each salt was evaluated for conversion efficiency by monitoring the peak height of the product methyl iodide.

Investigation of the Conversion Products of Selected Halogenated Organic Compounds

Instrument Design and Conversion Evaluation

For these experiments an identical instrument to that described above except was used except that a FID detector was utilized. The flow rates of air and hydrogen were 300 and 30 ml/min, respectively, for the FID. The detector was operated at 250°C.

Table 3 provides a list of compounds that were analyzed for their possible transformation to an alkyl iodide product using a zinc iodide conversion column and the conditions under which they were tested. All of these chemicals were used as received and prepared in carboys as previously described. Samples from carboys were introduced into the system via the sampling loop. Selected compounds were tested at concentrations ranging from 0.1 ppb to 100 ppm although most were only tested at 10 ppm. Most compounds were tested at two conversion column temperatures, typically 50°C and 150°C. Different concentration and temperature regimes were used when unique results prompted further investigation, as will be discussed below. A computer with a data acquisition card was used to monitor the output signal of the FID. The extent of conversion was determined by monitoring the peak areas of products produced. Because the response of the FID is approximately equal for compounds of equal carbon chain length and similar substitution pattern, peak areas were based on the following formula:

$$\% \text{conversion} = \frac{(\text{peak area for compound of interest})}{(\text{sum of peak areas for all products})} \times 100$$

Table 3. Thirty five alkyl halides that were tested for conversion to alkyl iodides with conversion column temperatures and concentration of alkyl halide tested.

Compound	Concentrations of Alkyl Halide Tested	Conversion Column Temperatures
Brominated Compounds		
CH ₃ Br	100 ppm to 100 ppt	30°C to 200°C
CH ₂ Br ₂	10 ppm	50°C, 100°C, 200°C
C ₂ H ₅ Br	0.1 ppm to 10 ppm	50°C to 150°C
1,2 – dibromoethane	10 ppm	50°C, 100°C, 150°C
n – bromopropane	0.1 ppm to 10 ppm	50°C to 150°C in 25°C inc.
2 – bromopropane	0.1 ppm to 10 ppm	50°C to 150°C in 25°C inc.
1,2 – dibromopropane	0.3 ppm to 10 ppm	100°C and 150°C
1,3 – dibromopropane	10 ppm	50°C, 80°C, 100°C, 105°C, 150°C
2,2 – dibromopropane	1 ppm and 10 ppm	30°C, 50°C, 100°C, 150°C, 180°C
2 – bromobutane	10 ppm	50°C, 100°C, 150°C
iso – butylbromide	0.3 ppm to 10 ppm	50°C, 80°C, 150°C
t – butylbromide	10 ppm	50°C, 80°C, 150°C
Chlorinated Compounds		
CH ₃ Cl	0.3 ppm to 100 ppm	30°C to 200°C
CHCl ₃	10 ppm	50°C and 150°C
CCl ₄	10 ppm	50°C, 100°C, 150°C
C ₂ H ₅ Cl	10 ppm	50°C and 150°C
C ₂ H ₃ Cl	10 ppm	50°C and 150°C
1,1 – dichloroethane	10 ppm	150°C
1,1,1 – trichloroethane	10 ppm	50°C and 150°C
1 – chloropropane	10 ppm	50°C, 100°C, 150°C
2 – chloropropane	0.3 ppm to 100 ppm	50°C and 150°C
2 – chlorobutane	10 ppm	50°C, 100°C, 150°C
t – butylchloride	10 ppm	50°C, 100°C, 150°C
Bromo-chloro Compounds		
CCl ₃ Br	10 ppm	150°C
CHClBr ₂	10 ppm	150°C
C ₂ H ₄ ClBr	10 ppm	150°C
Bromofluoro, chlorofluoro and bromochlorofluoro Compounds		
CF ₃ Br	10 ppm	150°C
CF ₂ Br ₂	10 ppm	150°C
CFBr ₃	?	?
CHFBr ₂	10 ppm	150°C
CF ₂ Cl ₂	10 ppm	50°C and 150°C
CFCl ₃	10 ppm and 110 ppm	50°C and 150°C
CF ₂ ClBr	10 ppm	150°C
CFClBr ₂	10 ppm	150°C

Determination of Methyl Bromide in Whole Air

Instrument Design

For these experiments an instrument similar to that initially described above was used except for the changes noted below. A schematic of this instrument is shown in Figure 2. Samples were introduced through a 6-way valve fitted with a sample loop. The sample loop size was varied and the details will be covered in the results and discussion. The carrier gas was dried beyond that described above and all samples were dried by use of an inline water trap. This trap was located between the outlet of valve V1 and the inlet of the main chromatography column and was constructed of 10 cm of 6-mm o.d. (5.33-mm i.d.) stainless steel tubing packed with ground magnesium perchlorate (Fisher Scientific). Initial chromatography was performed on a 30-m long by 0.53-mm i.d. mega-bore J&W Scientific GS-Q capillary column. The oven of the Varian 3700 and its associated controls were used to control the temperature of this column. This column was chosen over the SF-96 column due to its ability to separate oxygen from the remaining components of whole air. Post conversion column chromatography was achieved using a 1-m by 3-mm o.d 10% SF-96 on Chromasorb-W column. The temperature of the conversion column was controlled by wrapping the column with a heat tape. The heat tape was controlled by a variac and the temperature was monitored by thermometer. The temperature was kept stable by wrapping the heated column with fiberglass insulation.

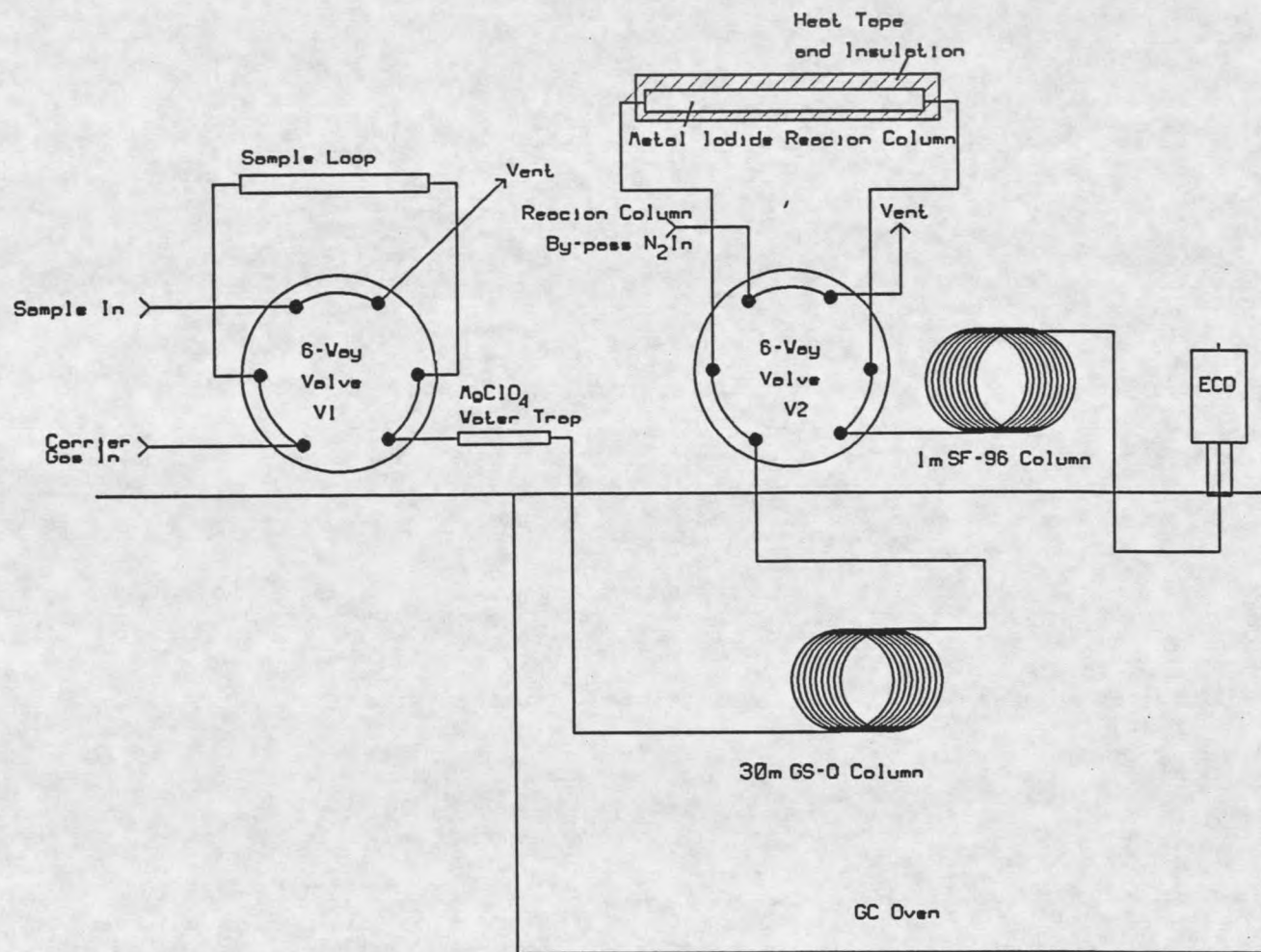

Figure 2. Schematic of instrument used to investigate the detection of methyl bromide in small volume whole air samples.

In order to minimize lab air intrusion into the sample introduction valve and bypass valves, they were each housed in a cardboard box enclosure that was purged with nitrogen. Effluent from the chromatographic columns was directed into either a ^{63}Ni or a ^3H electron capture detector. Two commercial ^{63}Ni detectors, Hewlett Packard and Varian, were utilized as well as a home-built ^3H detector.

The home-built tritium detector shown in Figure 3 was constructed as follows. The ECD cell was constructed from a Cajon brand VCR metal gasket face seal fitting to Swagelok tubing adapter (Idaho Valve #SS-4-VCR-6-400). Two modifications were made to the fitting. First, a hole was drilled into the center hex flat into which a 3-mm stainless steel tube was silver-soldered to provide the gas outlet and second, the metal gasket end of the fitting was bored out to 6.3-mm i.d. x 1 cm deep to provide a secure area for the foil. The Swagelok end of the fitting was fitted with a 60%/40% graphite/vespel ferrule. A pin was inserted through a hole in the center of the ferrule and served as the ECD anode, which was connected to the electrometer. The fixed frequency electrometer used to control the ECD was designed and constructed by John Bognar, a former undergraduate researcher in the Grimsrud lab. The foil was titanium-tritide on a 1 cm x 2 cm piece of .005" thick stainless steel (Safetylight Corp.). The foil has an activity of 350mCi. Carrier gas from the SF-96 column effluent was introduced into the cell via the gland fitting, which is part of the VCR unit.

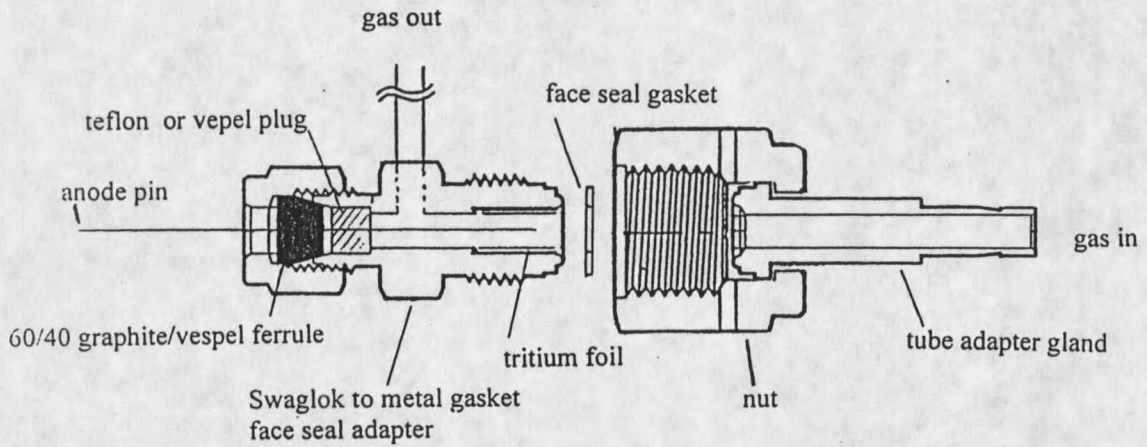

Figure 3. Schematic of a home built tritium ECD.

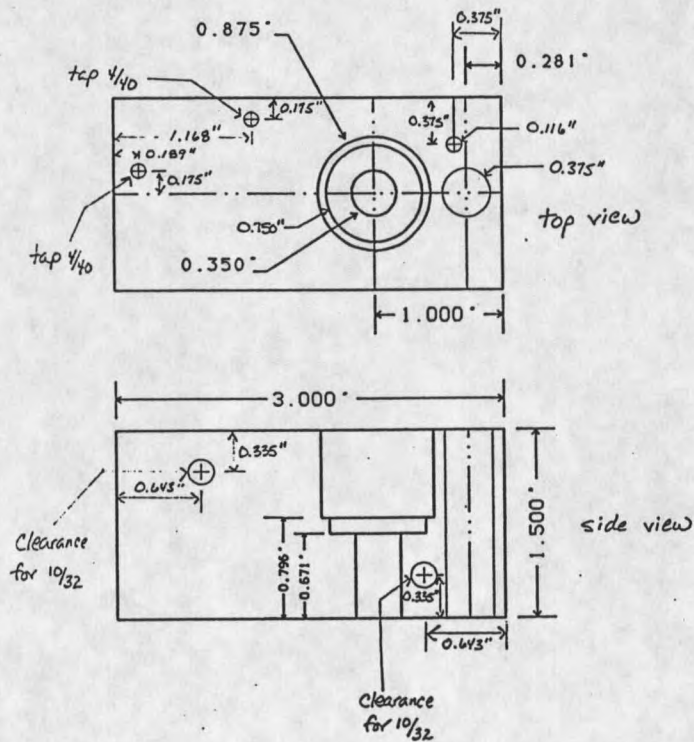

Figure 4. Schematic of heater block for tritium ECD.

The temperature of the tritium ECD was controlled and maintained by use of a heater block and cartridge heater. The cartridge heater was taken from an injection port heater on the Varian 3700. The controls for the heater were utilized to set the temperature of the ECD. A schematic of the heater block is shown in Figure 4. A 195°C thermal snap switch was mounted on the heater block in order keep the temperature of the ECD from going above this temperature. At temperatures above approximately 210°C the titanium tritide complex becomes volatile and represents a radiation hazard.

The commercial ^{63}Ni detectors were operated at 300°C and controlled with the commercial electronics. Both of these detectors are designed to operate in constant-current mode. The HP ECD and associated controls were part of a HP 5890 GC and the Varian ECD and associated controls were part of a Varian 3700 GC. Only the ECD and its controls were utilized on the HP instrument. This was accomplished by extending the 1-m SF-96 column from the port of Valco valve (V2) that was mounted to the Varian 3700 to the ECD inlet on the HP 5890.

Sample Preparation, Collection and Testing

Samples of compounds to be tested or used as spikes were made in carboys as above. Air samples were collected for testing in two manners. Grab samples were taken from inside the building and from the Montana State University grounds in 100-ml or 250-ml all-glass syringes (Popper & Sons, inc., New York) equipped with a Hamilton HV Plug Valve and were used immediately. Samples from off campus were collected for later use in a 500-ml or 4000-ml stainless steel canister. These canisters were internally treated with the SUMMA process. A Metal bellows valve (Nupro corp.) was fitted to the

opening on each end of the canister. A DC-powered diaphragm pump (KNF Neuberger, model N05SVI) was used to purge and fill these canisters. Canisters were filled to above ambient pressure. Samples from the stainless containers were removed by syringe through a port with septum that had been fitted onto one of the valve outlets after the filling process.

RESULTS AND DISCUSSION

In Situ Conversion of Methyl Bromide to Methyl Iodide

Interconversion of Alkyl Halides

Shortly after the development of the electron capture detector⁴⁴, interest in the possibility of derivatizing compounds that normally would not respond in an ECD with substituents that had EC active characteristics began to emerge.⁴⁵ Given that the electron capture detector is extremely sensitive and yet highly selective has made the ECD the detector of choice in applications where interference and/or sensitivity problems were an issue. In 1981, Watson, Ball and Stedman demonstrated that improved electron capture sensitivity to methyl chloride could be achieved by the in situ conversion of methyl chloride to methyl iodide.⁴² This was accomplished by passing a chromatographed sample through a secondary column containing sodium iodide. Upon exposure of the methyl chloride to sodium iodide at 350°C, Watson reported 80% of the methyl chloride was converted to methyl iodide. They reported the ability to detect 31 fg of converted methyl chloride in a 5-ml sample corresponding to a detection limit of 3 ppt which is an increase in detectability of 10⁴.

Then in 1984 Oomens and Noten reexamined the conversion of methyl chloride with an in-situ sodium iodide column.⁴⁶ They indicated that Watson's experiments were difficult to reproduce, that they had attempted to refine the conditions and subsequently detected only pg levels of methyl chloride. This corresponds to a detection limit equivalent to approximately 7 ppb, which is an order of magnitude above ambient levels.

This would seem to indicate that the technique would not be useful for the detection of methyl chloride in ambient air.

The desire to interconvert halides is not unique to this issue. As indicated in Larock treatise on organic transformations⁴⁷, there are many reactions in the organic synthesis realm that have been used to investigate the interconversion of halocarbons. Most of these, however, take place in the solution phase with one notable exception. In 1979, Tundo⁴⁸ showed that the conversion of bulk quantities of n-butyl bromide to n-butyl iodide was possible by pumping the liquid bromide into a heated in line column containing sodium iodide and a tetrabutyl phosphonium iodide phase transfer catalyst. As the vaporized n-butylbromide traversed the column, conversion efficiencies of 93% crude and 83% after purification were achieved with column temperatures of 160°C. He indicated that the transformation did not take place without the use of the PTC. Detection was by GC and NMR but was only used for the confirmation of product purity.

The mechanism by which this reaction takes place is generally believed to be S_N2 ⁴⁹, although neither Waston⁴² nor Oomans⁴⁶ mention this possibility. Tundo⁴³ has a limited discussion on this but indicates that these types of reactions can be assumed to be S_N2 .⁴³ Experiments performed in this study will take a cursory look at this issue.

Electron Capture Processes Involving Methyl Iodide

It is well established that the electron capture detector is more sensitive to methyl iodide than to methyl bromide.⁵⁰ The increased sensitivity to methyl iodide can be attributed to two factors. First, the electron capture rate constant for methyl iodide is much greater than it is for methyl bromide. This translates to a more efficient capture of

electrons within the cell and hence a greater response. This difference alone can account for an increase in sensitivity on the order of 10^3 over methyl bromide. Second, Grimsrud and Knighton⁵⁰ showed that, at low concentrations and relatively low temperatures, the response of an electron capture detector to methyl iodide appeared to have a response that was disproportionately large relative to the concentration that had been introduced into the system. Upon further study, it was proposed that this effect was a result of recombination of I^- with a proton to form HI, which then captures an electron. The iodide ion is essentially recycled, allowing for multiple electron capture events for each initial molecule of methyl iodide introduced into the ECD cell. This translates into a response that has stoichiometry greater than one.

There are two types of β sources, 3H and ^{63}Ni , that have historically been utilized by the Grimsrud research group for electron capture detectors. The tritium ECD has a higher activity, 350-800mCi, than the ^{63}Ni ECD, 15mCi, which translates to higher ion density within the ECD cell. It was postulated that this increased ion density might maximize the reactions due to I^- recycling and further increase the response due to methyl iodide. A comparison of the response of these two detectors to methyl iodide will be investigated.

Detection of Converted Methyl Bromide by Electron Capture GC

Given the preliminary findings of Watson⁴², Oomans⁴⁶ and Tundo⁴⁸, it is proposed that a similar method for the conversion of methyl bromide to methyl iodide could enhance its detectability and aid in the investigation of atmospheric methyl

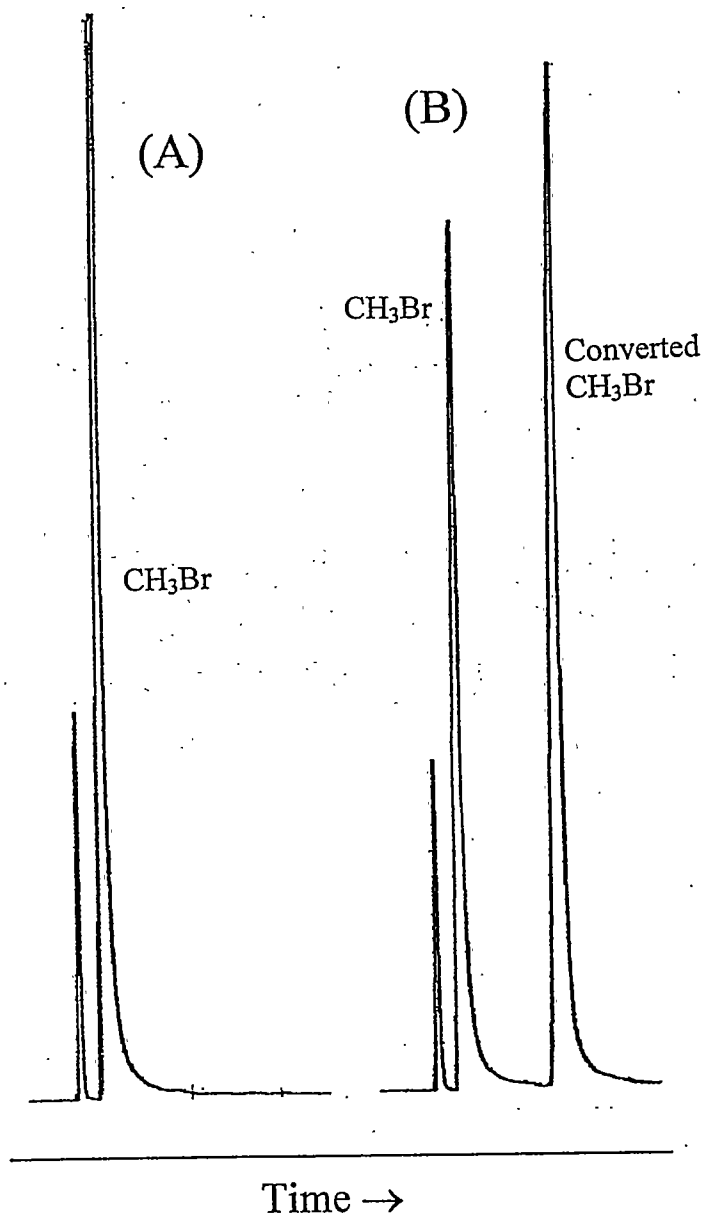

Figure 5. Chromatograms for the conversion of methyl bromide to methyl iodide utilizing a sodium iodide column at 150°C . (A) 1-ppm sample of methyl bromide that was not exposed to the sodium iodide (B) 1-ppm sample of methyl bromide that was run through the in-line sodium iodide conversion column.

bromide. Investigation of the conversion of methyl bromide to methyl iodide with the assistance of sodium iodide is a logical step toward the determination of the practicality of this procedure.

The two chromatograms shown Figure 5 in represent two 1-ppm samples of methyl bromide, one with and one without exposure to a 15-cm x 6-cm sodium iodide conversion column operated at 75°C. These chromatograms clearly indicate that conversion of methyl bromide to methyl iodide is possible although the concentration of the sample was quite high. The limited decrease in the methyl bromide peak and the very prominent methyl iodide peak demonstrates the sensitivity bias of the ECD toward methyl iodide. Since it was determined that conversion does, in fact, occur, a variety of metal iodide salts were evaluated in an attempt to improve the conversion efficiency and the detection limit.

Conversion Efficiencies of Metal Iodide Salts

Nineteen metal iodide salts and ammonium iodide were examined in order to determine their ability to facilitate this conversion. Table 4 provides a list of the conversion efficiencies observed for a sample containing 1 ppm methyl chloride and methyl bromide using a 15-cm x 6-mm column operated at 150°C and a Varian ECD detector operated at 250°C. For ease of comparison, the conversion efficiencies reported for each salt are relative to the conversion efficiency of methyl bromide using the zinc iodide column, which exhibited the most efficient conversion.

As seen in Table 4, methyl bromide was converted more efficiently than methyl chloride in every case. Seventeen of the salts displayed conversion activity toward

methyl bromide while only 12 showed measurable conversion activity toward methyl chloride. Three salts, SnI_2 , SnI_4 and NH_4I , could not be tested for their ability to convert due to their volatility at the test temperature. All three of these salts exhibited extreme column bleed followed by sublimation, which eventually plugged the tubing following the reaction column.

Zinc iodide and lithium iodide were found to be the most efficient at converting methyl bromide to methyl iodide while lithium iodide and magnesium iodide were observed to be the best at converting methyl chloride to methyl iodide. Lead iodide showed the best specificity toward the conversion of methyl bromide over methyl chloride. At 150°C , sodium iodide showed little activity toward methyl chloride or methyl bromide when compared to the results obtained at 350°C by Watson.⁴²

During this early phase of determination, the selectivity characteristics of the conversion salt toward methyl bromide were considered to be very important due to the potential interference of conversion products from the more abundant chlorocarbons in the atmosphere. As such, zinc iodide was considered to be the best column material on the basis of maximum overall conversion efficiency of methyl bromide and greater discrimination against methyl chloride. However, lead iodide was also tested further because of its greater selectivity.

Phase Transfer Catalyst Experiments

Based on previous work by Tundo, it had been surmised that the addition of a phase transfer catalyst (PTC) might assist in the conversion of methyl bromide to methyl iodide. It was also hoped that by utilizing the phase transfer catalyst, it might be possible

Table 4. Relative conversion efficiencies of methyl chloride and methyl bromide to methyl iodide by 20 different metal iodide salts. Values are normalized to the conversion of methyl bromide by zinc iodide at 150°C

Conversion Column Compound	Normalized conversion efficiencies of CH ₃ Cl and CH ₃ Br to CH ₃ I	
	CH ₃ Cl	CH ₃ Br
ZnI ₂	0.28	1.00
LiI	0.53	0.96
MgI ₂	0.50	0.81
NiI ₂	0.27	0.64
CoI ₂	0.18	0.38
MnI ₂	0.32	0.37
PbI ₂	<0.01	0.35
AgI ₂	0.01	0.24
CuI	0.02	0.20
BaI ₂	0.10	0.18
CsI	<0.01	0.18
RbI	<0.01	0.15
NaI	0.01	0.13
KI	<0.01	0.11
SrI ₂	0.07	0.09
CdI ₂	0.01	0.06
BiI ₃	<0.01	0.05
NH ₄ I	No Conversion	No Conversion
SnI ₂	No Conversion	No Conversion
SnI ₄	No Conversion	No Conversion

to operate at a lower conversion column temperature and that the phase transfer catalyst might work in a general sense for the conversion of a variety of bromides to iodides.

Tundo had used a variety of PTCs to promote the bulk synthesis of iodides from bromides.^{43, 48} Based on his work a number of systems were formulated and constructed, which included five common PTCs, tetrabutylammonium iodide, tetraethylammonium iodide, tetraethylphosphonium iodide, tetraphenylphosphonium iodide and tetrabutylphosphonium iodide and 2 column supports, Chromasorb-W and silica gel.

Since these reactions were performed on the instrument utilizing the FID, percent

conversions were based on the peak areas of the observed products and residual starting material as discussed previously in the experimental section.

Table 5 shows the PTC columns screened, the reaction conditions used and the actual conversion percentages of methyl chloride and methyl bromide that were achieved. The results for zinc iodide without a PTC are also included for a point of reference. The two columns that used silica gel as the support medium, which was specifically

Table 5. Conversion efficiencies, (%), of methyl bromide and methyl chloride to methyl iodide by phase transfer catalyst/metal iodide columns.

Phase Transfer Catalyst, Associated Column Contents and Their Weight Ratio	Conversion efficiencies (%) of CH ₃ Cl and CH ₃ Br to CH ₃ I		
	CH ₃ Cl	CH ₃ Br	Reaction Conditions
Tetrabutylammonium Iodide Silica Gel:PTC:KI 5.58:0.48:3.94	See Text		
Tetrabutylammonium Iodide Silica gel:PTC:ZnI ₂ 5.58:0.48:3.94	See Text		
Tetraethylammonium Iodide ChromasorbW:PTC:ZnI ₂ 3.6:0.50:6.24 Dry prep	1	13.6	125°C, 10 ppm
Tetraethylammonium Iodide ChromasorbW:PTC:ZnI ₂ 4.0:0.50:6.24 Wet prep	1	17	125°C, 10 ppm
Tetraethylphosphonium Iodide ChromasorbW:PTC:ZnI ₂ 4.0:0.50:5.82	1.5	31.6	125°C, 10 ppm
Tetrabutylammonium Iodide ChromasorbW:PTC:ZnI ₂ 2.65:0.48:3.94	49	91	105°C, 10 ppm
Tetrabutylammonium Iodide ChromasorbW:PTC:ZnI ₂ 2.67:0.48:3.96 Wet prep	19	100	125°C, 10 ppm
Tetrabutylammonium Iodide ChromasorbW:PTC:PbI ₂ 3.25:0.50:6.24	1	22	125°C, 10 ppm
Tetrabutylphosphonium Iodide ChromasorbW:PTC:ZnI ₂ 4.15:0.50:2.72 Wet prep	23	100	125°C, 10 ppm
Tetraphenylphosphonium Iodide ChromasorbW:PTC:ZnI ₂ 2.0:0.50:3.42	3	42	125°C, 10 ppm
Zinc Iodide with Chromasorb -W	23	82	150°C, 10 ppm

recommended in the literature by Tundo, adversely affected the chromatography by producing broad tailing peaks in even the simplest systems.

The columns containing the tetraethyl PTCs did not effectively convert methyl chloride or methyl bromide. Conversion percentages ranged from approximately 13 to 40% for methyl bromide and 1 to 3% for methyl chloride. One column utilized lead iodide as the metal iodide salt in conjunction with tetrabutylammonium iodide and Chromasorb-W. Conversion efficiency of methyl bromide was 22% and the conversion of methyl chloride was approximately 1%.

Columns with tetrabutylammonium iodide and tetrabutylphosphonium iodide, Chromasorb-W as the support and zinc iodide as the source of iodide performed exceptionally, achieving 100% conversion of methyl bromide at 125°C compared to the zinc iodide and Chromasorb-W only system, which showed 82% conversion at 150°C.

While these two systems resulted in excellent conversion rates, their use was not extensively pursued for two reasons. First, in these experiments column bleed was evident at temperatures above 125°C, on the FID system and as such, these systems were not tested on the system with the ECD. It is not known whether these columns would have been impractical to use with the ECD due to bleed but given the nature of the ECD, it was surmised that bleed would have been a problem. Secondly, since the column still needed to be heated there was no real advantage gained with respect to minimizing instrumental requirements. Since high conversion rates could not be achieved at or near room temperature, no further work with the PTC columns was performed.

Investigation of Conversion of Halogenated Organic Compounds to Iodinated Products

The obvious questions that now need to be addressed are: do other halogenated organics convert under these conditions, to what extent do they convert, and will any of these products interfere with the detection methyl bromide?

A list of 35 compounds was chosen based on atmospheric significance and availability in the lab. Table 6 shows a list of conversion efficiencies for a 10-ppm sample using a 15-cm x 6-mm ZnI₂ column operated at 150°C. Also shown is the percent iodo product produced, the percent other compounds produced and the number of compounds produced.

Conversion of Selected Halogenated Organic Compounds by Zinc Iodide

Of most significant importance is that multiply halogenated compounds do not convert to iodinated products, which means that the Freons and Halons will not further complicate the detection of methyl bromide due to the presence of multiple conversion products. It is rather unfortunate however that some of these compounds, such as HCFC-134a or dichloromethane, do not convert as an increase in their detectability could have been of benefit to the scientific community.

All primary haloalkanes tested converted to an iodoalkane, except n-chloropropane. The n-bromoalkanes all converted with greater efficiency than the corresponding n-chloroalkane. With respect to chain length, no specific trend was observed for the n-bromoalkanes. Methyl bromide, at 82%, converted better than ethyl bromide, 64%, but n-propyl bromide converted as well as methyl bromide, 82%.

1-bromo 2-methylpropane did not convert cleanly as evidenced by 21% iodo product and 51% of another product. Speculation concerning the identity of this product will be discussed in the next section. N-butyl bromide and longer chain hydrocarbons were not tested. The alkyl chlorides did follow a trend of decreasing conversion efficiency with increasing carbon chain length. Methyl chloride, at 23%, converted better than ethyl chloride, 7%, and n-propyl chloride did not produce any conversion products.

When bromo and chloro compounds substituted in the secondary or tertiary position were exposed to the heated reaction column two products were observed. One product has a retention time longer than the starting material, which is consistent with the formation of the iodo conversion product. The second product has a retention time that is shorter than the starting material, which would require the elimination of the halogen in order to explain the shorter retention time. The early eluting product was present in increasing amounts at higher temperatures. For instance, 2-bromopropane, utilizing a 150°C conversion column, gave 72% 2-iodopropane but also gave 28% of an earlier eluting product and no starting material. However, utilizing a 100°C conversion column, 2-bromopropane was converted to 83% 2-iodopropane and 5% of the early eluter with the remainder being starting material. These two conditions are shown in Figure 6. In addition to 2-bromopropane, three other secondary compounds were tested for conversion to alkyl iodides at a column temperature of 150°C. 2-bromobutane converted to give 1% 2-iodobutane, 2-chloropropane gave 60% iodo product and 2-chlorobutane converted to give 3% 2-iodobutane.

Table 6. Percent conversion of alkyl halides upon exposure to zinc iodide.

Compound	Total Percent Conversion (%)	Iodo Product (%)	Other Products (%)	Total Number of Products
Brominated compounds				
CH ₃ Br	82	82		1
C ₂ H ₅ Br	64	64		1
n - bromopropane	82	82		1
1-bromo 2-methylpropane	72	21	51	2
2 - bromopropane	100	72	28	2
2 - bromobutane	100	1	99	2
2-bromo 2-methylpropane	Inconclusive			
CH ₂ Br ₂	0			0
1,2 - dibromoethane	21		21	1
1,2 - dibromopropane	Inconclusive			
1,3 - dibromopropane	53	28/25		2
2,2 - dibromopropane	100		100	4
Chlorinated compounds				
CH ₃ Cl	23	23		1
C ₂ H ₅ Cl	7	7		1
C ₂ H ₃ Cl	0			0
1 - chloropropane	0			0
2 - chloropropane	74	60	14	2
2-chloropent-1-ene	0			0
2 - chlorobutane	99	3	96	2
2 - chloro 2 - methylpropane	100		100	1
CHCl ₃	0			0
CCl ₄	0			0
1,1 - dichloroethane	0			0
1,1,1 - trichloroethane	28	5	23	2
Bromo-chloro compounds				
CCl ₃ Br	No recovery			
CHClBr ₂	0			0
1-bromo- 2-chloroethane	6		6	1
Bromofluoro, chlorofluoro and bromochlorofluoro compounds				
CF ₃ Br	0			0
CF ₂ Br ₂	0			0
CFBr ₃	0			0
CHFBr ₂	0			0
CFCBr ₂	0			0
CF ₂ ClBr	0			0
CF ₂ Cl ₂	0			0
CFCl ₃	0			0

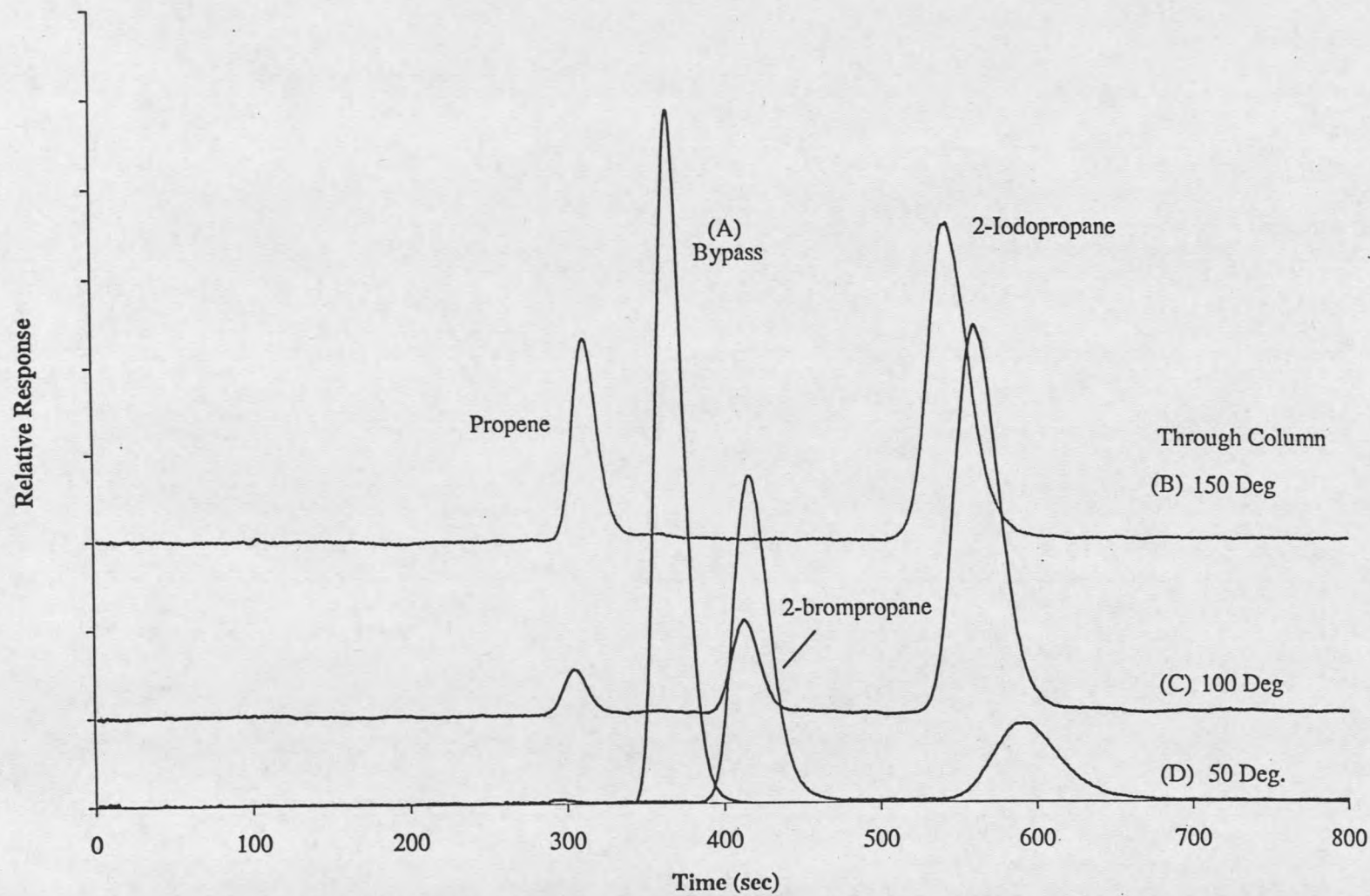

47

Figure 6. Chromatograms for 2-bromopropane. (A) Bypass mode, Through column mode with the reaction column at (B) 150°C, (C) 100°C; (D) 50°C.

With respect to the identity of the early eluting peak, there are two likely products that would give such a result. First, the halogen might be substituted with a proton, producing the unsubstituted alkane, or second, the halogen might be eliminated, producing an alkene product. The system is very dry, however, and the only apparent source of a proton would be from water. We therefore concluded that the product is a result of the elimination of a halogen and a hydrogen atom.

Only two tertiary alkyl halides were tested. The data for 2-bromo 2-methylpropane was inconclusive with regard to whether the main peak was an early eluter or starting material. The starting material was also contaminated as evidenced by multiple peaks in the chromatogram. 2-chloro 2-methylpropane gave 100% early eluter at all temperatures tested between 50°C and 150°C.

Twenty of the compounds tested were substituted with two or more halogens. Addition of multiple halogens disabled the production of iodo products except in limited cases. 1,1,1-trichloroethane apparently produced 5% of an iodo product. Only one compound, 1,3-dibromopropane, was tested where an unsubstituted carbon separated two carbon atoms that were each substituted with a halogen. The increase in retention time observed in the chromatogram, shown in Figure 7 is consistent with the formation of the iodobromo and the diiodo product. As indicated in Table 6, 1,3-dibromopropane was converted to 28% iodobromopropane and 25% diiodopropane with the balance being starting material. It would appear that the separation of the bromines by the unsubstituted carbon allows each one to act independently and thus the formation of the diiodo product is possible. The multiply substituted compounds that did not convert

include many of the anthropogenic compounds that are a significant source of the chlorine and bromine in the atmosphere. The non-conversion of these compounds means that they will not interfere with the determination of methyl bromide in whole air samples and that the response due to them may be used as an internal standard.

One particular result that was found to be unique was the conversion of 2,2-dibromopropane. Figure 8 shows that on exposure to the heated reaction column, 4 products were formed, which all had earlier elution times than the starting material. Speculatively, there are several options which might explain this observation. Elimination of one or both bromines might lead to 2-bromopropene, propyne or allene. Some combination of elimination and hydration might give propane, propene or 2-bromopropane. Although interesting, the identity of the products has not been elucidated since it was not paramount to this project. Future research may look into this issue further.

Of all the compounds examined that showed any conversion activity, only methyl bromide, methyl chloride and 1,1,1-trichloroethylene are expected to be present in whole air. As such, the criteria by which the metal iodide was chosen needed only to be based on conversion efficiency. As evidenced by this work, zinc iodide was therefore chosen as the conversion compound for use in the remainder of the study.

Optimization and Characterization of Conversion Column

After zinc iodide had been chosen for the conversion compound, it was necessary to optimize the parameters of the column to maximize conversion efficiency. A series of

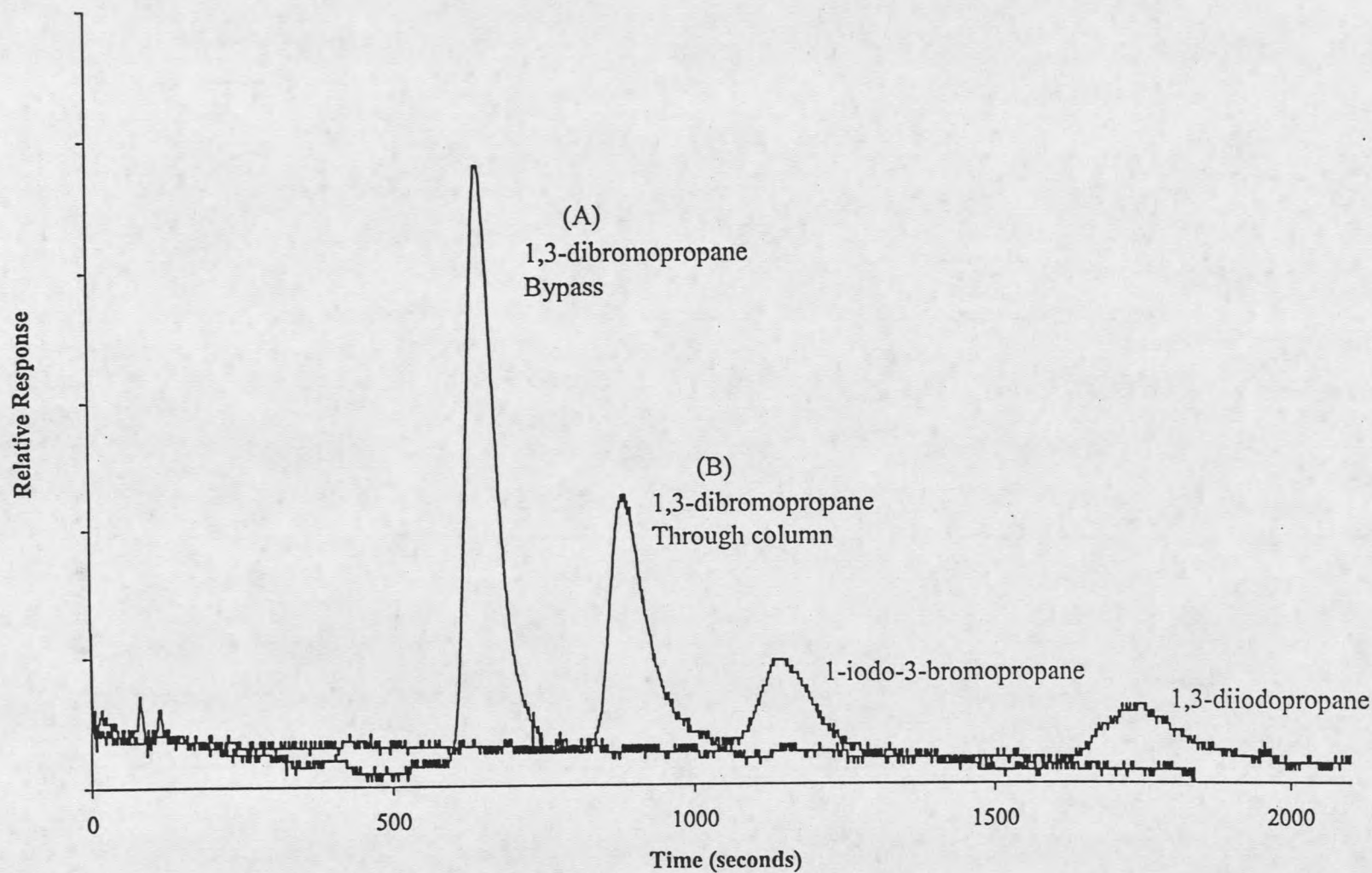

Figure 7. Chromatograms of 1,3-dibromopropane. (A) Bypass mode; (B) Through column mode with the reaction column at 150°C

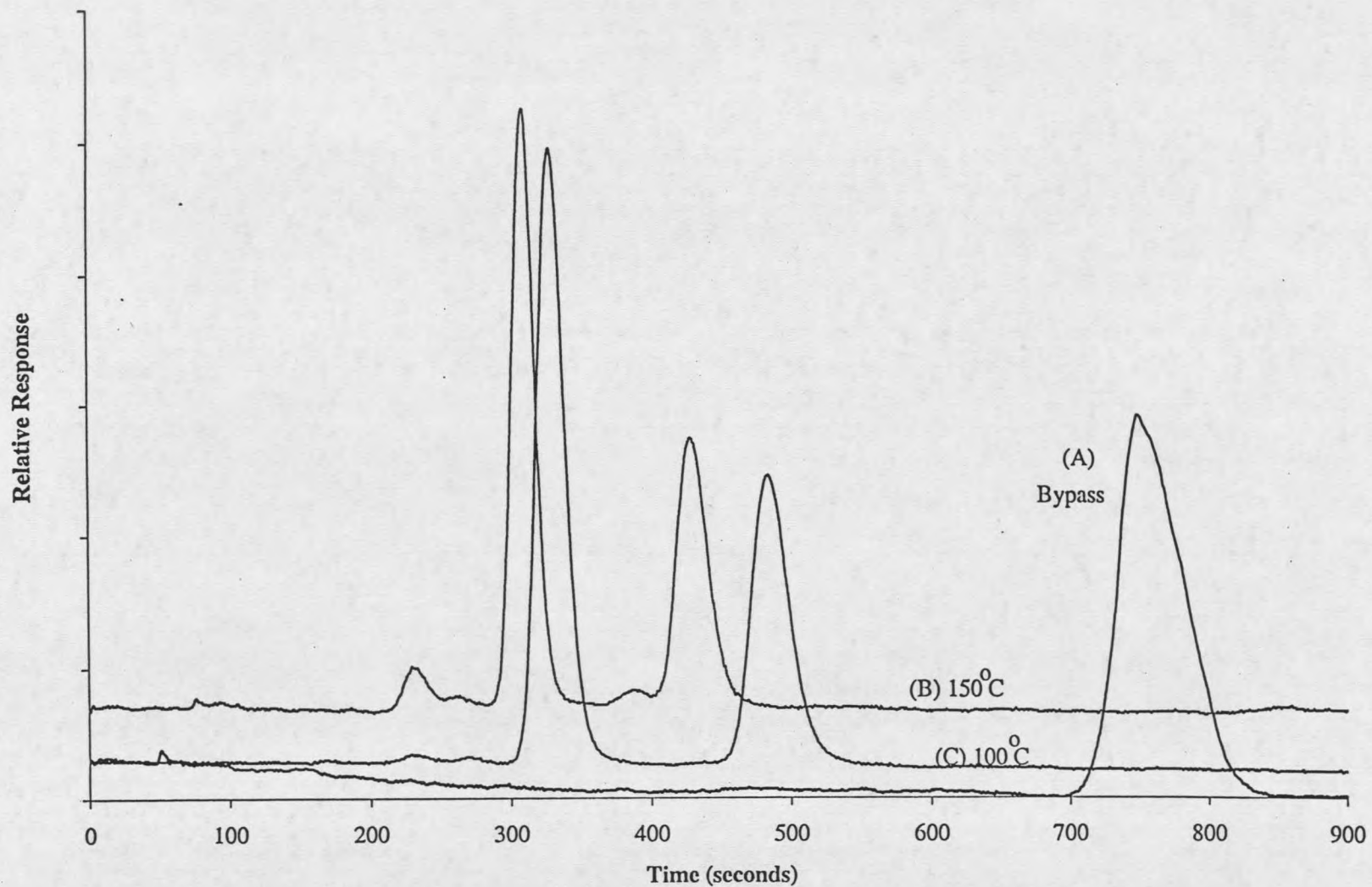

Figure 8. Chromatograms of 2,2-dibromopropane. (A) Bypass mode; Through column mode with reaction column at (B) 150°C; (C) 100°C.

experiments helped to determine the optimum column temperature, column configuration and carrier gas flow rate. Also investigated was the ability of zinc iodide to convert methyl bromide to methyl iodide at a variety of concentrations and the stability of the methyl iodide that was created in order to ensure that it was not degraded in the heated reaction column.

Effect of Conversion Column Temperature on Conversion Efficiencies

In order to determine the effect of temperature on the conversion process, samples of methyl bromide were introduced into the system with conversion column temperatures ranging from 50°C to 150°C in 25°C increments. Figure 9 shows a compilation of chromatograms for the conversion of five samples of 10-ppm methyl bromide using a 15-cm x 6-mm ZnI₂ column at each of the temperatures listed above using the FID for detection. The chromatograms show that as temperature increases, the conversion of methyl bromide also increases as evidenced by the increase in the methyl iodide product peak. Later in the study it was determined that at temperatures higher than 150°C, a decrease in standing current of the ECD and loss of sensitivity was observed as a result of column bleed. Studies for this thesis involving the FID did show some improvement of conversion at 200°C but again this temperature was not practical on the ECD systems. A 150°C conversion column temperature was therefore chosen as the optimum temperature to operate the conversion column.

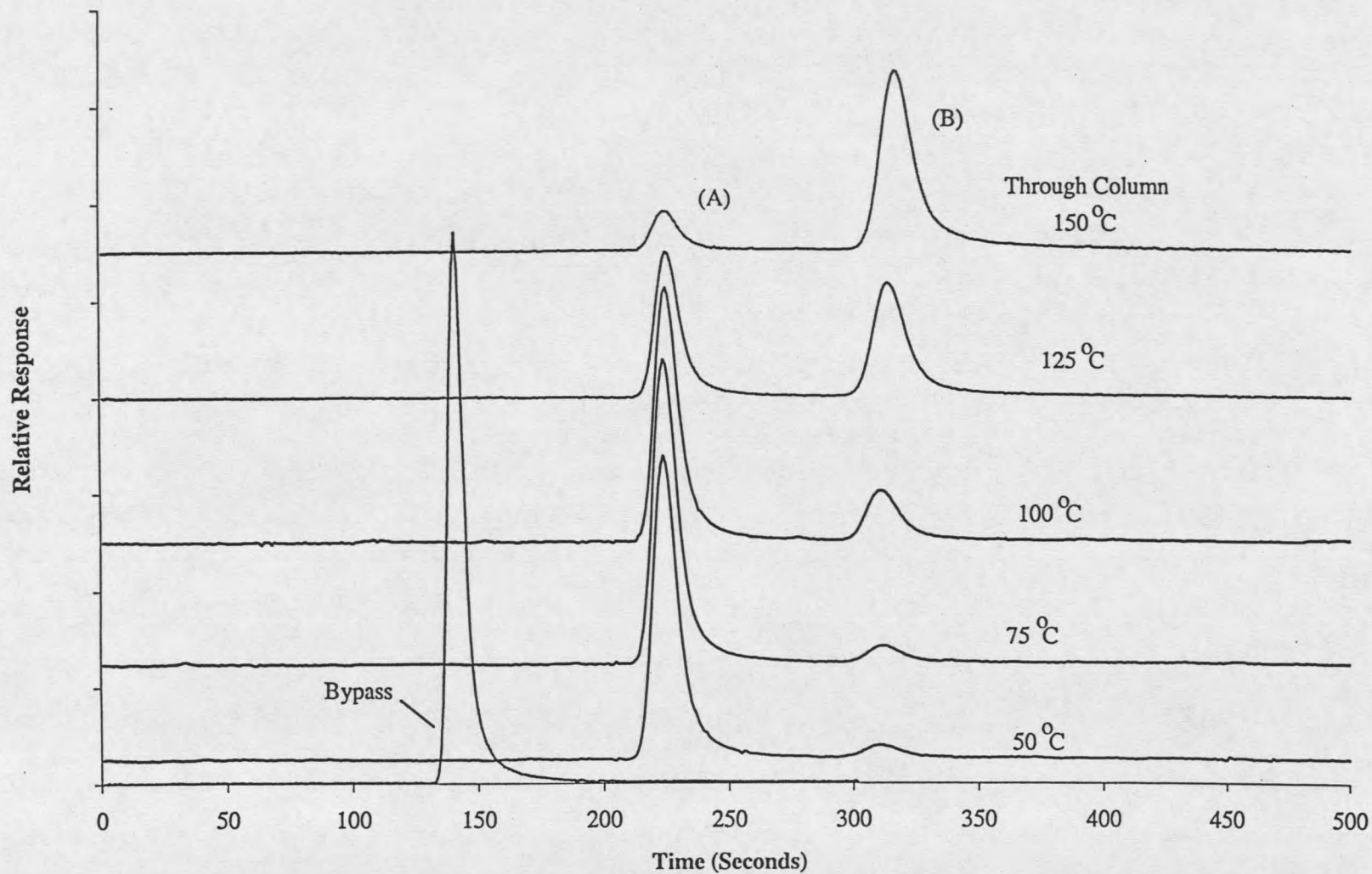

Figure 9. Chromatograms for 10 ppm samples of methyl bromide that were introduced into the instrument, which was in through column mode, with the conversion column at 50°C, 75°C, 100°C, 125°C and 150°C. (A) Unconverted methyl bromide; (B) Methyl Iodide Product.

Effect of Conversion Column Configuration on Conversion Efficiency

Several conversion column configurations, which differed in length and diameter, were investigated in order to determine if there was an optimum configuration and to determine if contact time with the metal iodide or volume of metal iodide was more important. These included a 5-cm x 12.5-mm o.d. column, a 15-cm x 6-mm o.d. column, a 38-cm x 6-mm o.d. column and a 135-cm x 3-mm o.d. column. All of these were packed with zinc iodide and conditioned as above except the 135-mm x 3-mm o.d. column, which required a vacuum on one end to facilitate filling. Columns were evaluated based on the maximum response and impact on chromatography of methyl iodide resulting from conversion of methyl bromide.

As reported above the conversion percentage for zinc iodide in the 15-cm x 6-mm o.d. column was 82%. The 38-cm x 6-mm o.d. column contained approximately 2.5 times the volume of zinc iodide as the 15-cm column and conversion efficiency for this column increased 5% relative to the 15-cm column. Although greater efficiency was achieved with the 38-cm column, flow restriction as a result of the longer column caused detrimental flow rate changes when switching between bypass and through column mode. The 5-cm x 12.5-mm o.d. column contained approximately 1.5 times the volume of zinc iodide as the 15-cm column but it showed a decrease in conversion efficiency of approximately 10%, when compared to the 15 cm column. The 135-cm long by 3-mm o.d. column, similar to that used by Watson⁴² and Oomans⁴⁶, was found to be unacceptable due to extreme flow restriction. It was hoped that this column would allow for better chromatography due to the minimization of different tubing sizes. The 15-cm x

6-mm o.d. column proved to be the best compromise between conversion percentage and flow restriction. As such this column was used throughout the remainder of this thesis.

Effect of Carrier Gas Flow Rate on Conversion Efficiency

The change in conversion efficiency based on residence time in the conversion column was tested by running a series of experiments in which samples were introduced into the system at a variety of carrier gas flow rates ranging from 25 to 51 ml/min. The ECD itself is stable only over a limited range of flow values due to the chemistry that must take place in the cell. It is important to understand that by adjusting the carrier gas flow, a change in signal may be due to a change in the ECD characteristics as well as a change in the conversion column efficiency. Traditionally, in chromatography, a faster flow rate gives a narrower, taller peak for a given compound.

Figure 10 shows chromatograms for samples containing methyl bromide at the flow rates of 51, 47, 35, 30 and 25 ml/min. The peak shape did not improve as flow increased from 25 to 50 ml/min whereas signal intensity actually decreased. Maximum signal was realized at the lower flows with no degradation of peak shape. This would seem to be indicative of a change in reaction column efficiency based on residence time in the column since the flow rate changes tested here should not have so drastically effected ECD response. Based on these results a flow rate of 25 to 30 ml/min was considered optimal.

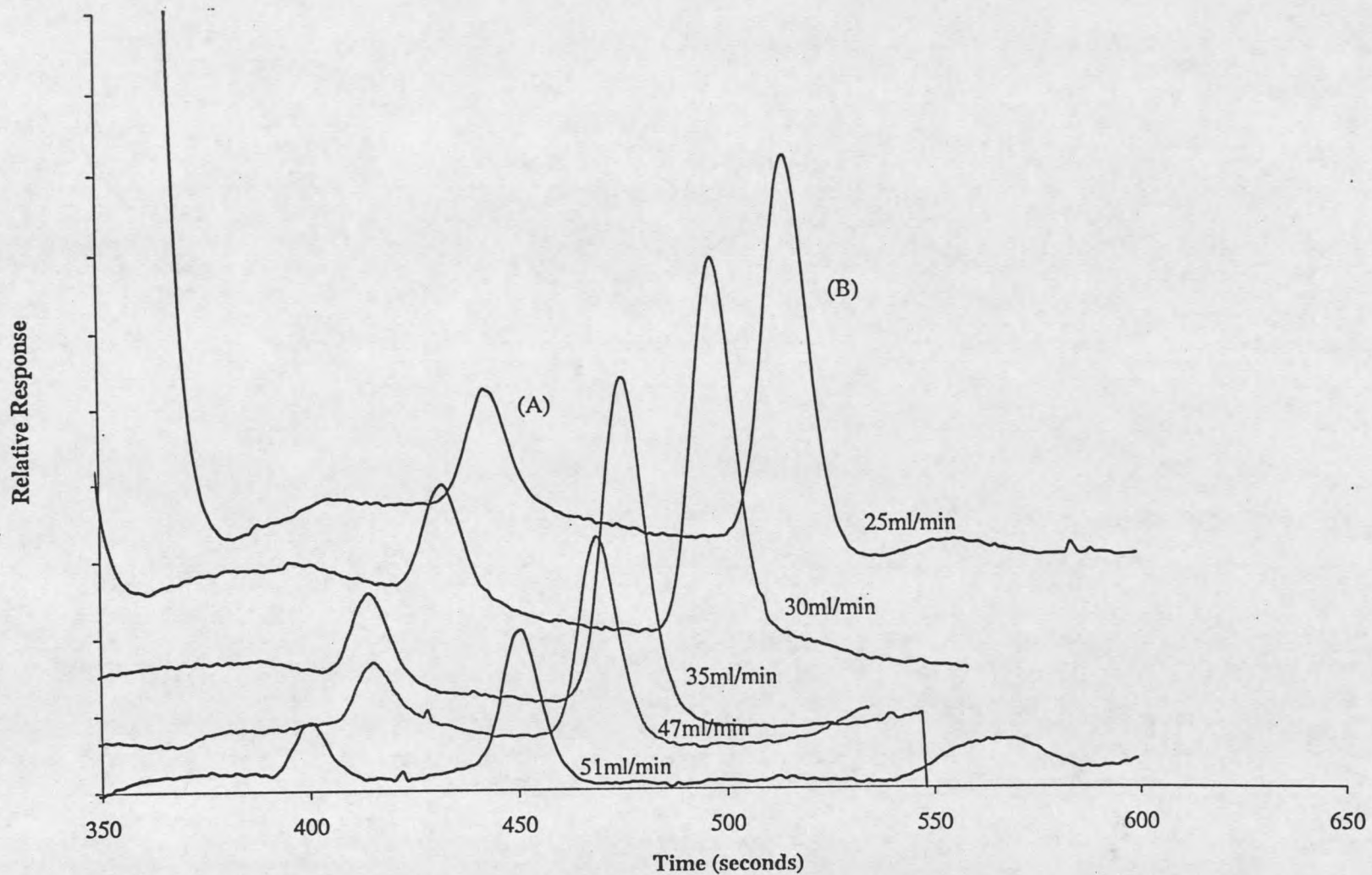

Figure 10. Chromatograms for the conversion of (A)methyl chloride and (B)methyl bromide to methyl iodide for carrier gas flow rates of 51, 47, 35, 30 and 25 ml/min.

Concentration Effects on Conversion Efficiency

A series of 2-ml methyl bromide samples ranging in concentration from 1000 ppm to 60 ppt were introduced into the system, which was fitted with a 15-cm x 6-mm i.d. zinc iodide reaction column to examine what effect if any sample concentration might have on the observed conversion efficiency. High concentrations were tested on the FID since the ECD response is non-linear at high concentrations. The conversion efficiencies reported using the FID were based on peak areas as previously discussed in the experimental section while the ECD values were based on a calibration curve for methyl iodide.

Table 7 shows a list of observed conversion percentages of methyl bromide in order of decreasing concentration. The FID data shows a weak trend that is probably real, indicating the inability of the selected column to convert at high concentrations. No trend with ECD data is observed which is taken to indicate uniform conversion with low sample concentration. Greater variability in the ECD data and the difference between the FID and ECD is due to the difficulty associated with calibrating the ECD response.

Determination of Potential Product Loss or Degradation

Two tests were performed to ensure that products being formed in the reaction column was not being lost as a result of the heat of the column or other interactions within the conversion column. In an attempt to determine the stability of methyl iodide within the heated reaction column a 2-ml sample of 10-ppm methyl iodide was

Table 7. Percent conversion efficiency of methyl bromide to methyl iodide as a function of concentration.

Concentration of methyl bromide 2-ml CH ₃ Br sample on Varian FID	Percent conversion of methyl bromide to methyl iodide
1000 ppm	74
750 ppm	74
500 ppm	75
250 ppm	74
100 ppm	76
70 ppm	76
50 ppm	78
30 ppm	78
10 ppm	78
2-ml CH ₃ Br sample on Varian ECD	
620 ppt	83
558 ppt	87
496 ppt	89
434 ppt	87
372 ppt	87
310 ppt	86
248 ppt	90
186 ppt	93
124 ppt	88
62 ppt	63

introduced into the system, which was in the through reaction column mode and utilized the FID detector. A second identical sample was then introduced with the system in bypass mode. The resulting peak heights were monitored and compared. This would assure that the methyl iodide produced within the column during a normal run is not thermally degraded. Results showed that there was minimal loss of methyl iodide as a result of exposure to the heated metal iodide column which would indicate that any methyl iodide produced as a result of methyl bromide conversion was available for detection.

To ensure that by-products within the conversion column that resulted from the use of the column, possibly $ZnBr_2$, were not effecting the conversion process, a reverse experiment was performed. A $ZnBr_2$ reaction column was made and conditioned utilizing the same protocol as described in the experimental section. This column was then used as the others except that an attempt was made to convert methyl iodide to methyl bromide. A 2-ml sample of 10-ppm methyl iodide was introduced into the system fitted with the conversion column at $150^\circ C$. Samples were run in both BP and TC mode. By comparing the peak areas of BP and TC runs, it was shown that the reverse reaction did not take place as no product peak was detected and no decrease in the methyl iodide peak was observed.

Determination of Methyl Bromide in Whole Air

After experimental conditions and instrumental configuration regarding the conversion process had been determined, the next step is to ascertain whether this process can be used to aid in the detection of methyl bromide in whole air. Based on the findings of the work conducted up to this point the following experimental setup was constructed.

- Sample introduction – 2 ml gas sample loop
- Chromatographic column #1 – 1m 10% SF-96 on Chromasorb-W at ambient temperature
- Conversion column – ZnI_2 with Chromasorb W at $150^\circ C$
- Chromatographic column #2 – 1 m 10% SF-96 on Chromasorb-W at ambient temperature

- Detector – Tritium (^3H) – fixed frequency ECD at 100°C

The first experiment performed to test for the detectability of methyl bromide in whole air involved introducing a 2 ml whole air sample, taken from the lab window, into the system that was in TC mode and checking for methyl bromide based on previously determined retention times.

The result of this experiment was disappointing. The standing current was immediately lost as the oxygen entered the detector and remained that way for several hours. In addition, the total standing current was not recovered for nearly one week. When the same experiment was run with a reaction column at 50°C , the ECD was not adversely affected, but no methyl bromide was observed.

In order to determine the cause of this effect, experiments reverted back to the use of the FID. The FID essentially does not respond to oxygen and as such, it was possible to determine if a compound in real air was generating a new product in the reaction column or causing extreme column bleed. The only difference between this system and the one used previous, is the use of the FID.

Over the course of several days, 20 samples of 14 ppm methyl bromide in instrument grade air (Air Liquide Inc.) were introduced into the instrument via the sampling loop with the instrument in TC mode and the zinc iodide reaction column at 150°C . These samples were not pre-treated or cleaned in any way. Column stability was evaluated by monitoring the peak area of the methyl iodide product.

These experiments indicated that no significant degradation of signal took place as a result of exposure to real air samples. Rather it was speculated that oxygen produced

a product within the heated reaction column that was detrimental to the ECD. No unforeseen peaks or column bleed were observed when using the FID with whole air samples.

Based on these findings a new strategy was adopted. The bypass valve, usually reserved for changing the flow path from bypass mode to through column mode between runs would be used in mid run. Initially a run would start with the system in bypass mode in order to direct the oxygen contained in the sample around the reaction column. Then, after the oxygen had eluted, the system would be switched into through column mode thereby allowing only the components that elute after oxygen to traverse the reaction column. This technique proved to be successful on the FID system in that it did not perturb the detector output except for a short period, most likely due to pressure changes within the system. Based on this, the same experimental protocol was attempted on the system fitted with the ECD.

Initially, a 2-ml sample of whole air was introduced into the system with the system in the bypass mode. The enhanced sensitivity of the ECD to oxygen with respect to the FID immediately became apparent. The oxygen peak was very large, the tailing end of which eluted for several minutes. If sufficient time was allowed for the oxygen to clear the system, as evidenced by the return of the chromatographic trace to baseline, methyl bromide was also bypassed from the reaction column. It became evident based on this that the SF-96 column could not effectively separate oxygen from methyl bromide and that a different chromatographic column, which could provide more efficient separation of oxygen and methyl bromide would be needed.

Another packed column containing 25% OV-101 on Chromasorb-W was tried in place of the initial SF-96 chromatography column with similar results. Inspection of the commercial literature showed that the J&W GS-Q capillary column was very effective at separating halocarbons. However, it was not clear as to its ability to separate these products from atmospheric concentrations of oxygen. There was also a concern that this capillary column may not have the ability to handle the relatively large 2-ml sample used in these experiments. However, the Mass Spectrometry Facility at Montana State University had a 3-m x .53-mm GS-Q column and made it available to this project for testing purposes. It was installed onto the instrument in place of the initial SF-96 column. The second SF-96 column was retained to assist in the separation of conversion column products and to act as a guard column for the ECD. The GS-Q column was not designed to operate at ambient temperature and at this point it was necessary to remove the conversion column from the GC oven so that the oven could be used to heat the GS-Q column. The conversion column was subsequently heated by a heat tape, as described in the experimental section. It was also at this point that a MgClO_4 drying tube was installed, as described in the experimental section, in order to remove the water from whole air samples. The GS-Q column provided the required separation of oxygen from methyl bromide and Figure 11 shows a chromatogram of a 2-ml sample of whole air with a methyl bromide spike that was run in bypass mode. In this run, the starting temperature was 60°C. The temperature was immediately ramped at 5°C/min to a final temperature of 100°C. The final temperature was held for 15min.

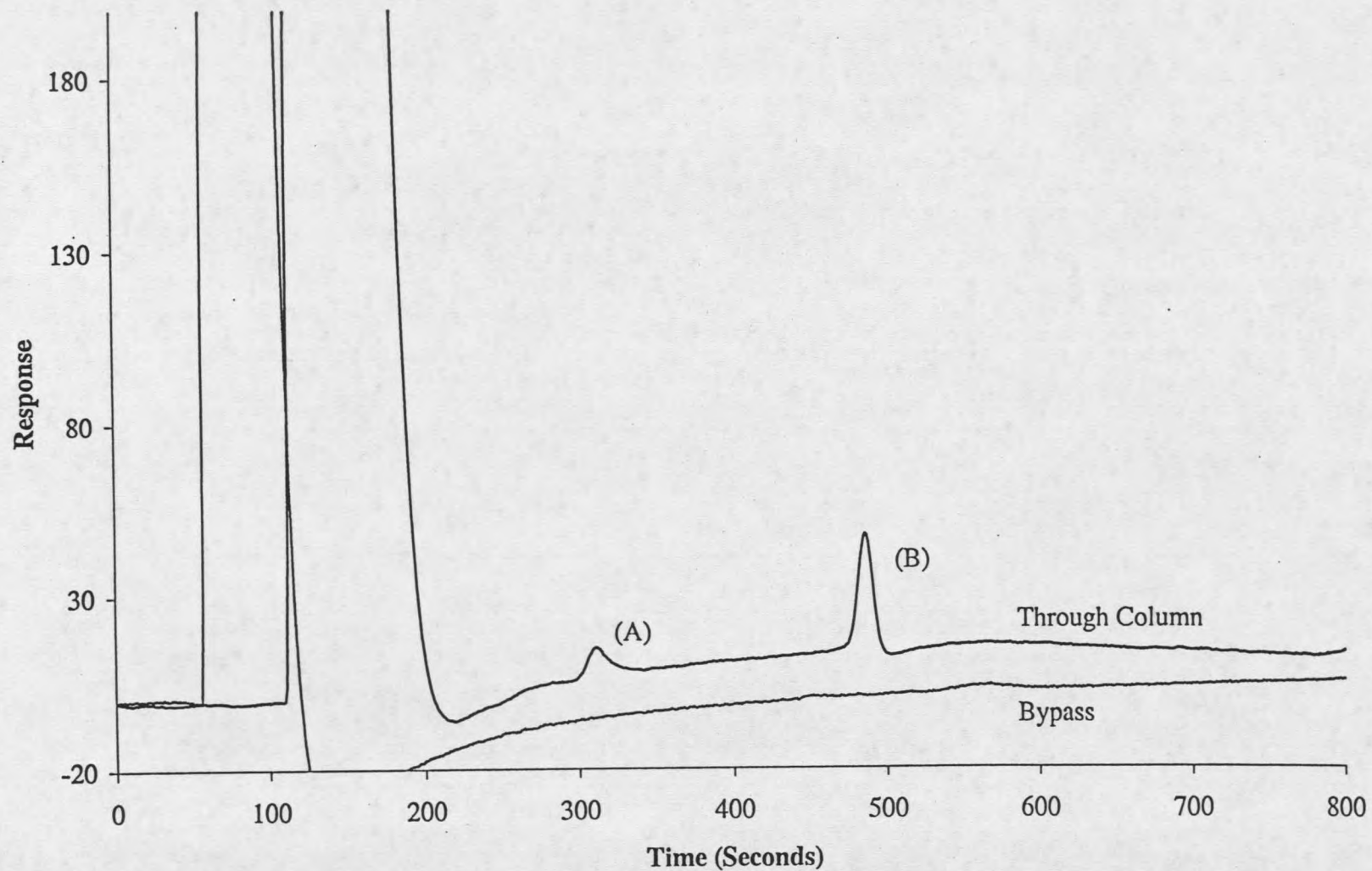

Figure 11. Chromatogram of whole air with a methyl bromide spike in bypass mode and through column mode utilizing the GS-Q capillary column. (A) Methyl iodide peak due to conversion of methyl chloride; (B) Methyl iodide peak due to conversion of methyl bromide.

Study of Tritium ECD and Electrometer Behavior

Based on the success of separating methyl bromide from oxygen in whole air, a GS-Q column was purchased and installed. However, with the current setup, the response due to atmospheric concentrations of methyl bromide was still insufficient to enable reliable detection and it became necessary to explore other areas of optimization, one of which included the use of a tritium detector. The ^3H ECD cell used in this study was designed and constructed in order to investigate the effect of this type of ECD on the detection of methyl iodide. This ECD was operated in the fixed-frequency mode. By operating in the fixed-frequency mode, the electrons within the cell are collected at the positively pulsed anode pin at a fixed time interval. A base current resulting from the ionization of a small portion of the carrier gas is established as the standing current. Any change in the standing current is a result of a loss of electrons due to electron capture reactions taking place within the cell and is proportional to the amount of analyte present.

It was necessary to characterize several parameters of this ECD that can effect response. These included the anode pin thickness and position within the detector, the pulse period and the temperature at which it is operated. Due to the nature of the chemistry within the ECD, simply adjusting each parameter to maximize the standing current does not necessarily produce the maximum response. As such, the response of methyl iodide was monitored as each of the different parameters was varied.

Anode pins were constructed from 316 stainless steel rod stock and were cut to a length of approximately 80 mm. Each pin was washed with detergent and water, rinsed with hexane, acetone and ethanol and allowed to air dry. Pin diameters of 1.57 mm, 1.14

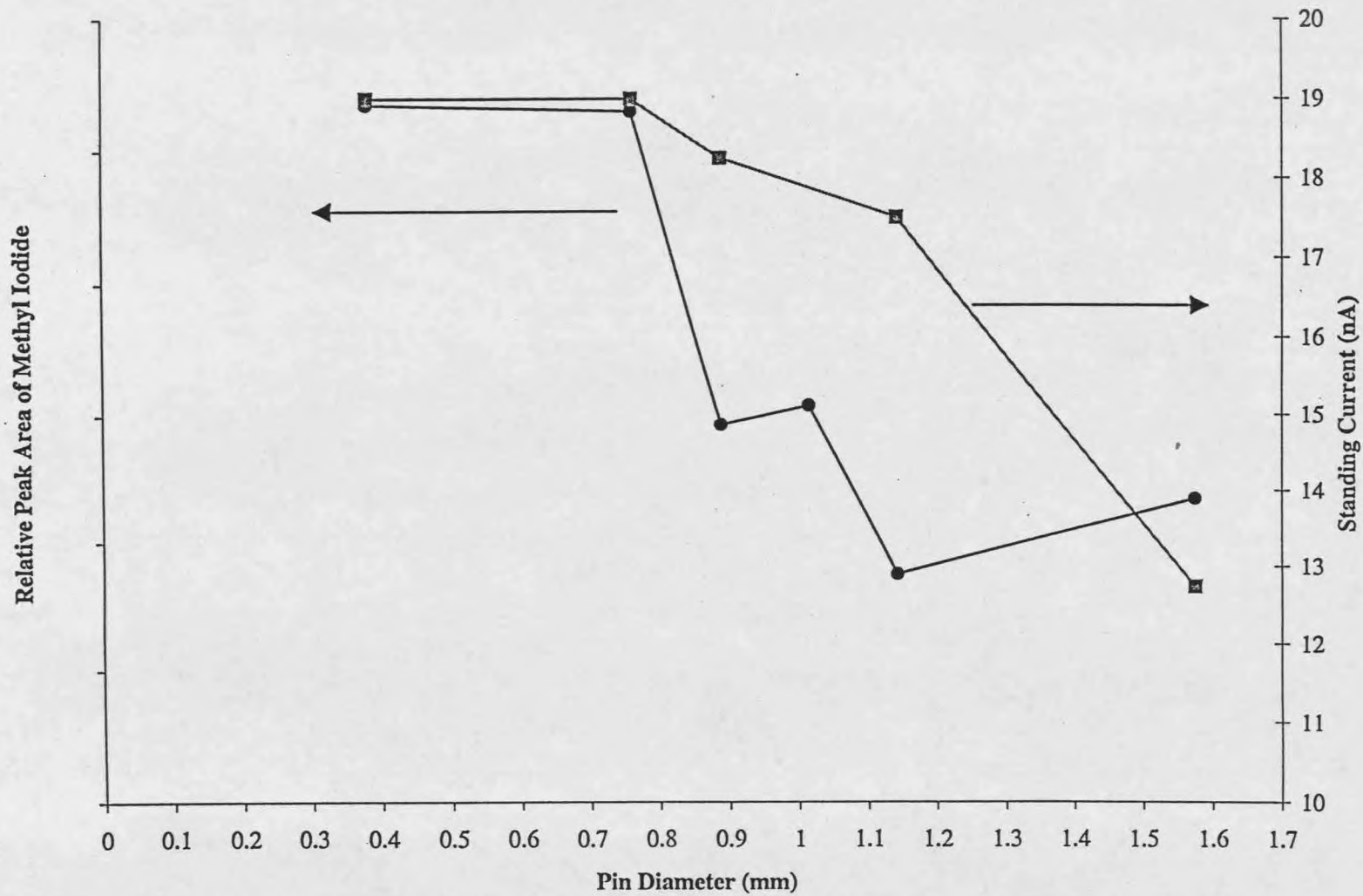

Figure 12. Plot of tritium ECD cell response to methyl iodide and standing current vs. ECD anode pin diameter.

mm, 1.01 mm, 0.89, 0.76 mm and 0.38 mm were examined and each pin was mounted into the ECD such that they were centered in the cell both radially and longitudinally with respect to the tritium foil. The response of methyl iodide was monitored for each pin size. The response and standing current was plotted vs. the pin diameter and is shown in Figure 12 and reveals that both the standing current and response generally increase as pin diameter decreases. The 0.38-mm pin showed nearly identical behavior as the 0.76 mm pin. The 0.76-mm pin was chosen as the optimum pin since it was slightly more robust than the 0.38-mm pin.

The position of the 0.76-mm anode pin within the ECD cell was adjusted longitudinally along the center radial axis of the ECD cell over a 9-mm range while the response of methyl iodide was monitored. The position values were normalized such that 0 would represent the pin fully withdrawn from the cell and 1 would represent fully inserted into the cell with respect to the tritium foil. For this experiment the normalized pin positions ranged from -0.1 to +0.8. The system was allowed to stabilize after each adjustment and prior to the introduction of a new sample. Figure 13 shows the peak area of methyl iodide from the conversion of methyl chloride in whole air verses the normalized pin position. Inspection of this figure shows that the optimum response is achieved when the tip of the pin is inserted approximately to the center of the tritium foil.

The pulse period, the rate at which the cell contents are sampled, was adjusted from 150ms to 350ms in 50-ms increments, while the response due to methyl iodide was monitored. The system was allowed to stabilize prior to running each sample. Figure 14

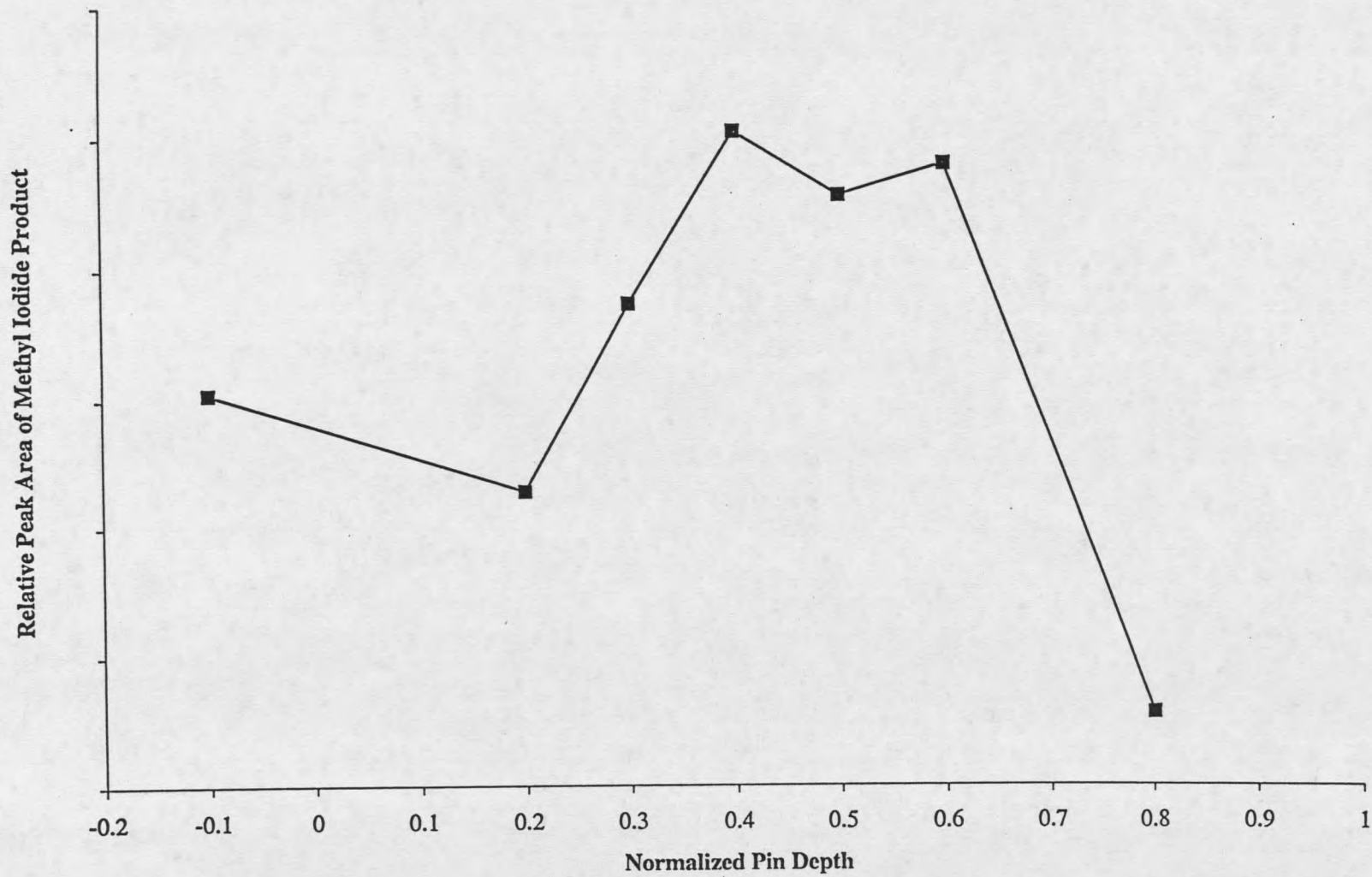

Figure 13. Graph of tritium ECD response to methyl iodide vs. ECD anode pin position laterally within the cell

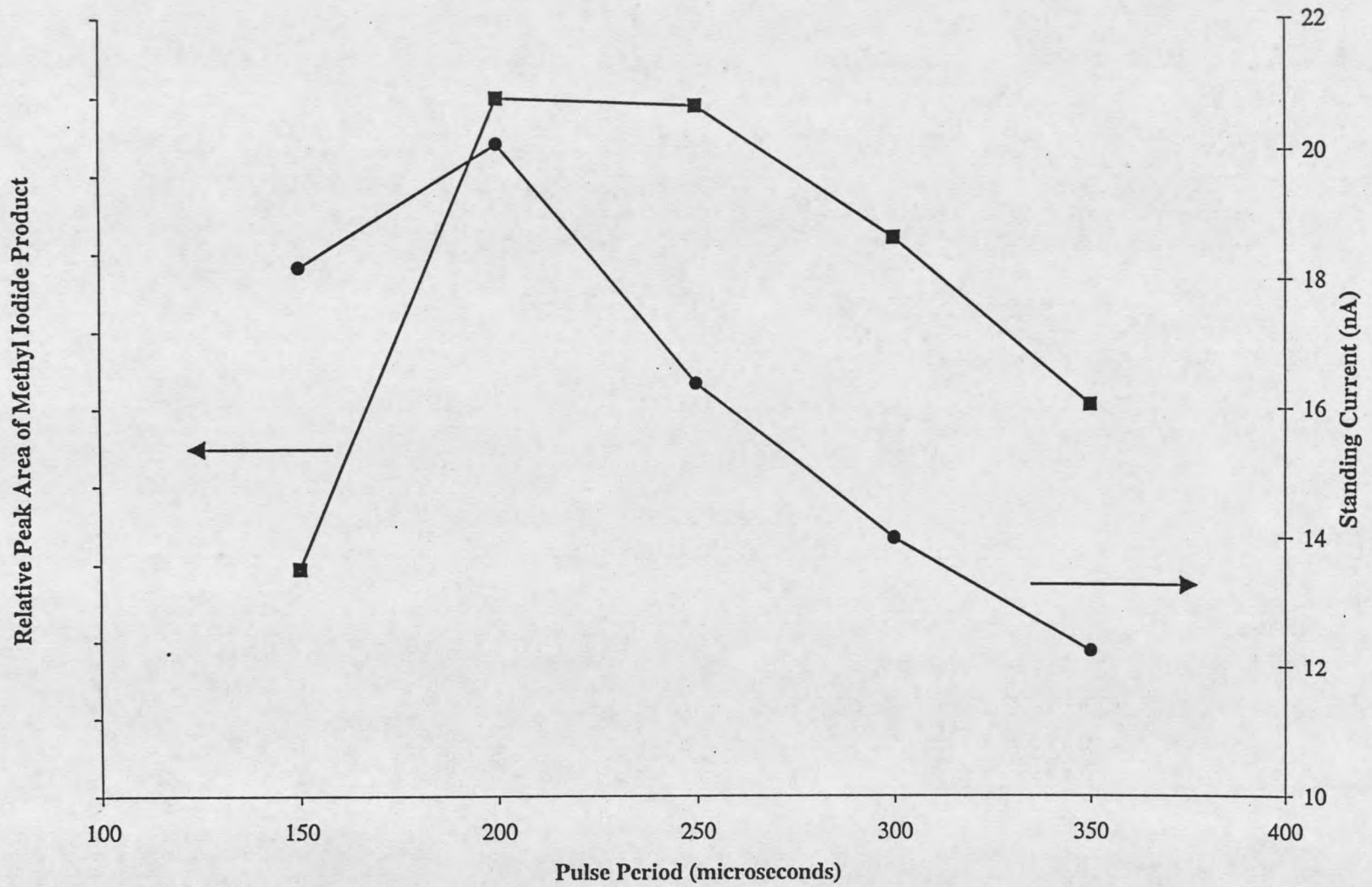

Figure 14. Plot of tritium ECD response to methyl iodide and ECD standing current and vs. ECD pulse period.

shows a plot of peak area and standing current vs. pulse period. A pulse period of 200 ms was found to produce the greatest response to methyl iodide.

With the mechanical features of the tritium ECD optimized, further enhancement of the methyl iodide signal was explored by investigating the temperature dependence of the ECD response to methyl iodide. To investigate this, samples of whole air were introduced into the system with the ECD cell at a variety of detector temperatures and the response of methyl iodide was monitored. Figure 15 shows a plot of response vs. temperature over the temperature range of 50 – 120°C. This figure indicates that methyl iodide displayed a slight, 10%, positive temperature dependence up to 100°C with a decrease at 120°C. Grimsrud and Knighton⁵⁰ reported that the ECD response to methyl iodide at 75°C and 150°C displayed a small negative temperature dependence. It is possible that the same trend is seen here, however the limited data does not allow for a complete analysis.

It was noted that each time the internal area of the ECD was exposed to ambient room air as a result of column changes, there was a noticeable increase in the standing current and an increase in the response to methyl iodide by a factor of approximately 2.5. This "enhancement" degraded in 24 to 36 hours after the cell was resealed if the cell temperature was kept below 100°C. If the temperature was 120°C to 140°C, the enhanced response of methyl iodide and the increase in standing current would degrade in a matter of a few hours. It was speculated that the contact of the internal cell surface with water vapor might be the cause of the enhancement. To investigate the potential effect of water vapor on the tritium cell, a separate source of wet nitrogen was introduced

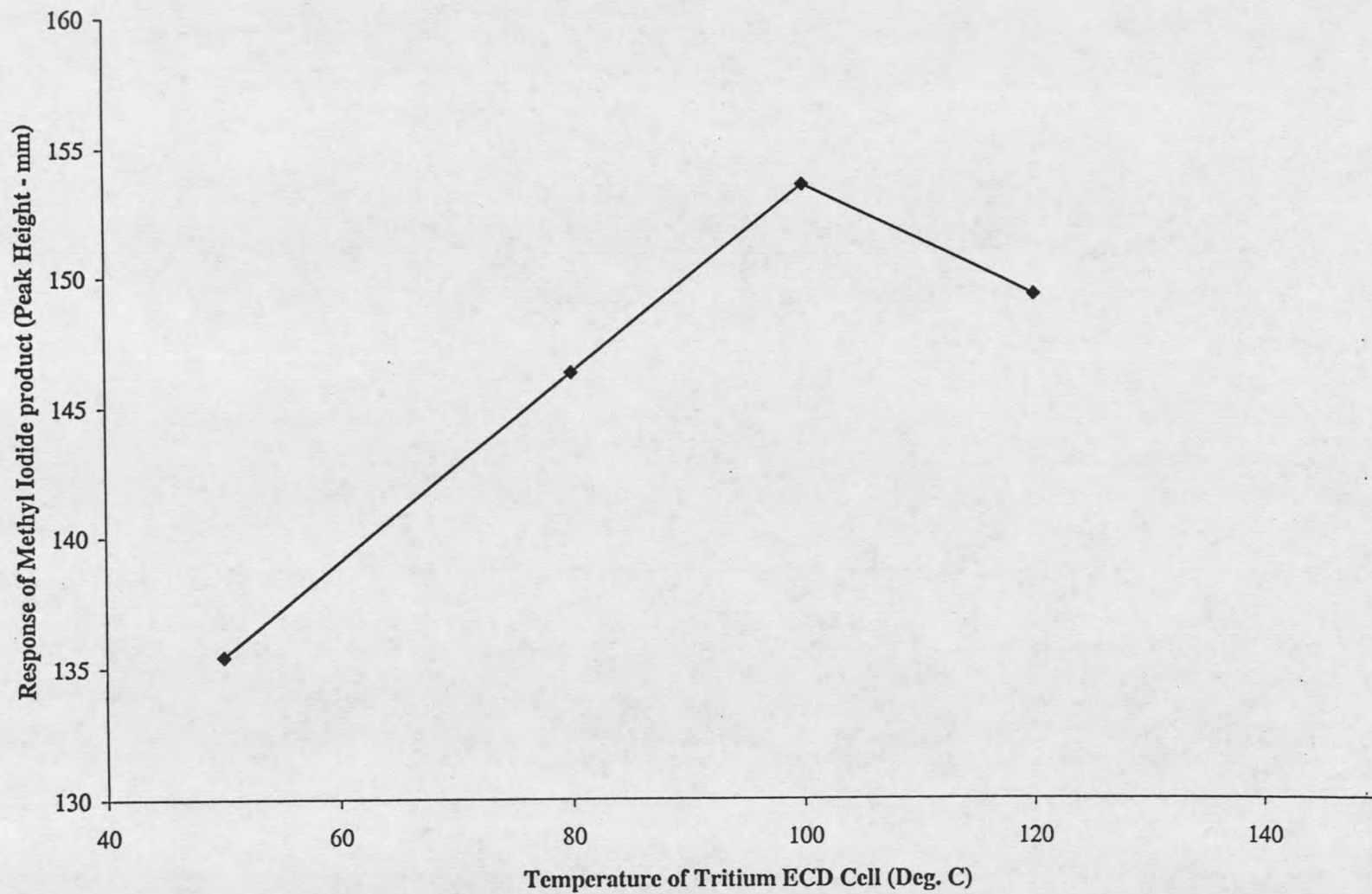

Figure 15. Plot of tritium ECD response to methyl iodide vs. ECD cell temperature.

directly into the ECD as make-up gas. Oxygen was removed from this nitrogen by an in-line Oxytrap. Wet nitrogen was generated by installing a T, which was fitted with a 6-mm o.d. glass tube filled with water, into the makeup nitrogen line after the oxygen trap. The water-filled tube was wrapped with a heat tape and heated to approximately 40°C. This water-saturated nitrogen was directed into the ECD cell via a T fitting, which was installed onto the inlet of the cell. An immediate improvement in methyl iodide signal was observed. The graph in Figure 16 shows a plot of response of methyl iodide product vs. temperature for cell temperatures of 32°C, 70°C, 100°C, 120°C and 140°C along with the data from the temperature study above, which did not utilize the makeup gas. This figure indicates that with the wet makeup gas, methyl iodide displays a substantial improvement in response and a slight 5% positive temperature dependence from 32°C to 100°C and a slight negative temperature dependence from 100°C to 140°C. Ten samples were run over the course of several days with the detector at 100°C to confirm that the enhancement of the signal was reproducible and did not diminish with time. The ECD response to methyl iodide was reasonably consistent with a standard deviation of +/-7.5%. Removing the source of wet nitrogen caused the system to slowly reestablish the lesser response for methyl iodide similar to that shown above.

Sample Size

Reliable responses for background levels of methyl bromide continued to be troublesome to attain, even though the separation of real air components had been achieved and the response of the tritium ECD had been optimized. Several methods of

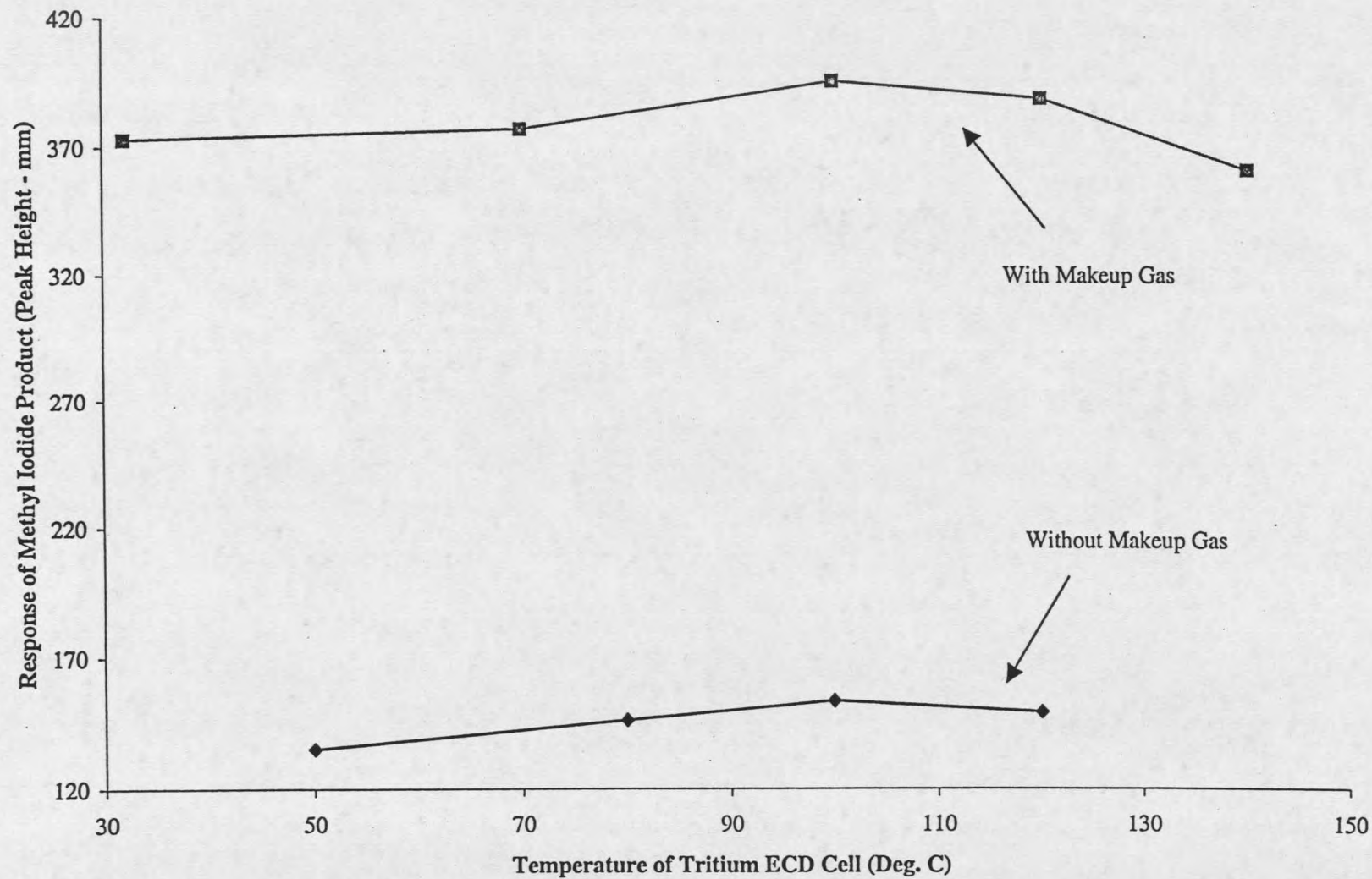

Figure 16. Plot of tritium ECD cell response to methyl iodide vs. temperature, with and without the addition of wet nitrogen makeup gas.

improving S/N were considered including cryofocusing, which admittedly was the very technique that this project was trying to overcome. Though expectations were low, it was decided that the sample size would be increased. The sample size was increased from 2 ml to 5 ml and the observed response increased from essentially undetectable to an identifiable peak. The response, however, was still insufficient to enable reliable quantitative detection. The sample size was increased to 20 ml and, quite surprisingly, the observed response increased without degradation of peak shape. In one final attempt to increase the S/N ratio, the sample size was increased to 45 ml. The observed response for the 45-ml sample increased by a factor of 2.3 over the 20-ml sample and 6.6 times over the 5-ml sample, again without significant peak distortion as shown in Figure 17. Conventional wisdom would have suggested that such large sample volumes would not be feasible on a capillary column. It is unclear why this actually worked, other than to suggest that a very crude form of cryofocusing takes place by holding the temperature at 20°C prior to starting the temperature program and holding it there for a sufficient time to ensure that the 45 ml volume from the sample loop has been flushed onto the head of the column. It has been demonstrated that through the conversion of methyl bromide to methyl iodide and utilizing an ECD detector, atmospheric concentrations of methyl bromide are easily detectable in 45 ml samples without the use of traditional cryofocusing or adsorbent trapping techniques.

Comparison of ^{63}Ni and ^3H ECD Detectors

Now that adequate signal due to the conversion of methyl bromide had been achieved, it seemed appropriate to compare the sensitivity of the ^{63}Ni ECD for methyl

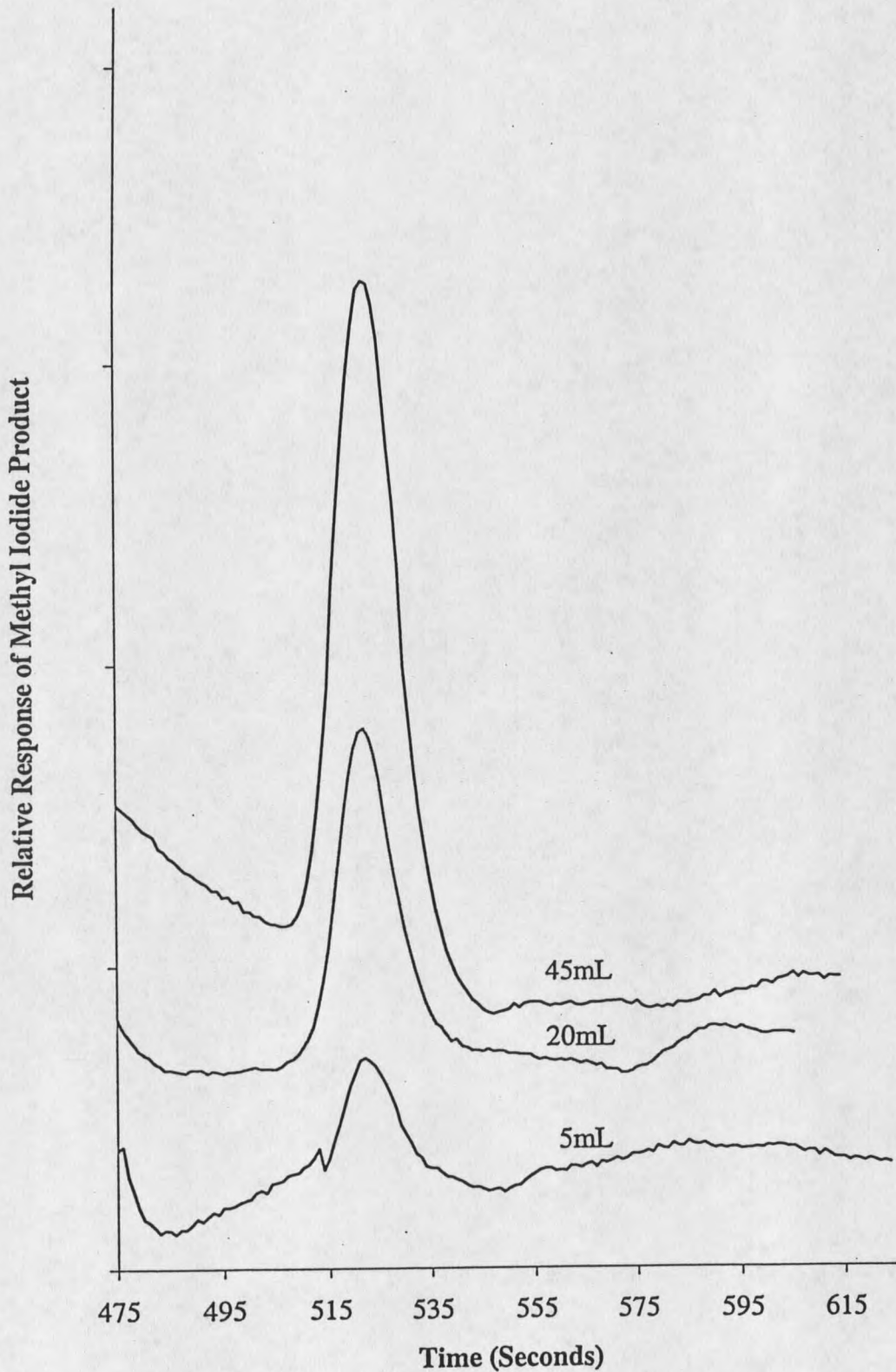

Figure 17. Chromatograms of methyl iodide product response in whole air vs sample size for 5, 20 and 45 ml sample sizes

iodide to that of the tritium ECD. It was necessary to determine if the tritium was indeed the best detector for this application based on the reasons discussed above. The ^{63}Ni detector afforded the opportunity to test the response due to methyl iodide over a broader temperature range and it was hoped that the commercial electronics might lead to improved signal to noise ratios. The response due to methyl iodide was screened with the ^{63}Ni detector at temperatures of 100°C and 300°C with and without the use of the wet nitrogen makeup gas. The instrumental set-up was identical to the system used above except that the output of the SF-96 guard column and the wet makeup gas were plumbed into a HP5890 ECD (Hewlett Packard). Performance was evaluated by introducing samples of whole air into the system fitted with the ^{63}Ni detector, monitoring the response due to methyl iodide and comparing the observed responses with those that were obtained by using the tritium detector at 100°C while utilizing wet make-up gas.

In order to compare the two detectors, the ^{63}Ni detector was initially tested at 100°C with wet nitrogen makeup gas. A sample of whole air was introduced into the system and the response of methyl iodide product was monitored. The observed peak height response of the methyl iodide product was 93% less than the response that was observed utilizing the tritium ECD under similar conditions. The wet makeup gas was then removed and another sample of whole air was introduced into the system. The peak height response due to methyl iodide product was 90% less than the response that was observed utilizing the tritium system with wet nitrogen makeup gas. The temperature of the ^{63}Ni ECD was then raised to 300°C , a more traditional operating temperature for a ^{63}Ni ECD, and the flow of wet makeup nitrogen was reestablished. A sample of whole

air was introduced into the system and the response due to the methyl iodide product was monitored. The peak height observed was approximately 89% less than the response that was observed when utilizing the tritium ECD at 100°C with wet nitrogen makeup gas. The flow of makeup gas was again removed and a sample of whole air was introduced into the system. The peak height due to the methyl iodide product observed was 85% less than the peak height observed when utilizing the tritium detector. Two chromatograms of whole air, which demonstrate this effect, are shown in Figure 18. Chromatogram A shows the response due to whole air utilizing the tritium cell and chromatogram B shows the response due to whole air utilizing the ^{63}Ni detector. Note that the peak due to Freon -11 is almost identical in both chromatograms, thereby demonstrating the significant enhancement of the methyl iodide product due to the tritium cell. As discussed in the introduction, this enhancement is most likely due to the recycling of I^- within the ECD cell as was put forth by Grimsrud et al^{50, 51}.

The raw sensitivity of the tritium ECD is undoubtedly greater, however, as further signal enhancement was attempted through the decrease of signal attenuation, it became apparent that the response of the ^{63}Ni ECD cell showed a better signal to noise ratio. When the attenuation was adjusted to give full scale pen deflection on the chart recorder the S/N ratio was approximately 55. When the attenuation was similarly adjusted for the ^{63}Ni ECD the S/N ratio was better than 150:1 for which the noise measurement was limited to measuring the width of the pen trace. Because of these results, the ^{63}Ni ECD was utilized throughout the rest of this study.

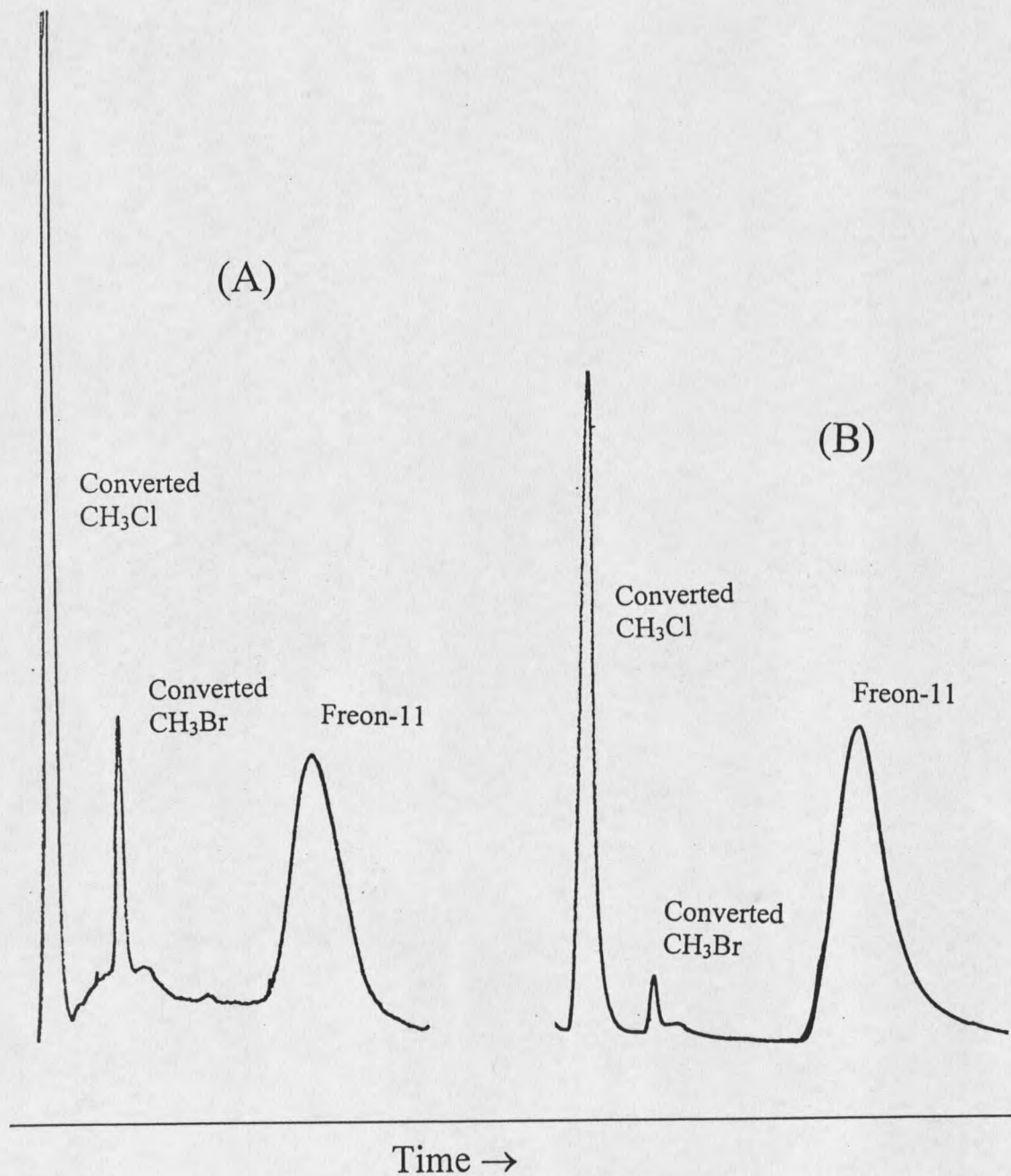

Figure 18. Chromatograms of whole air on the (A) 100°C tritium detector with wet nitrogen makeup gas and the (B) 300°C ^{63}Ni detector with no makeup gas. Both chromatograms were run in through-column mode with the conversion column at 150°C

Final Optimization of Chromatographic Parameters

With the signal maximized through the use of the 45-ml sample and the 300°C ⁶³Ni ECD it was necessary to optimize chromatographic separation of the methyl iodide product from closely eluting atmospheric components that were not observable prior to these improvements. Several different column temperature programs were tested in an attempt to maximize separation and minimize elution time. Isothermal runs from 40°C to 90°C were tried, but at lower temperatures run-times were exceedingly long and peaks were excessively broadened and at high temperatures many peaks, including the product peak methyl iodide, coeluted with other atmospheric constituents. It was apparent that a temperature program would be necessary to get good separation of the methyl iodide product from other atmospheric constituents. Temperature program variables including initial temperature, initial hold time, ramp rate and final temperature were adjusted in an attempt to optimize the separation of methyl iodide product peak from other atmospheric components. Initial starting temperatures greater than 35°C produced poor results presumably due to the inability of the sample contents to collect at the head of the column before starting the chromatogram. Hold times were varied from 0 to 12min in an attempt to ensure that the contents of the sample loop had time to flush onto the head of the column and to investigate the effect of minimizing this time. A hold time of 5 min proved to be adequate for allowing the contents of the sample loop to flush onto the column. Ramp rates effected the degree to which the components of the sample were separated, but as with the isothermal runs, slow ramps, 10°C/min, produced long elution times and broad peaks. Fast ramp rates, 80°C/min, proved to be effective at minimizing

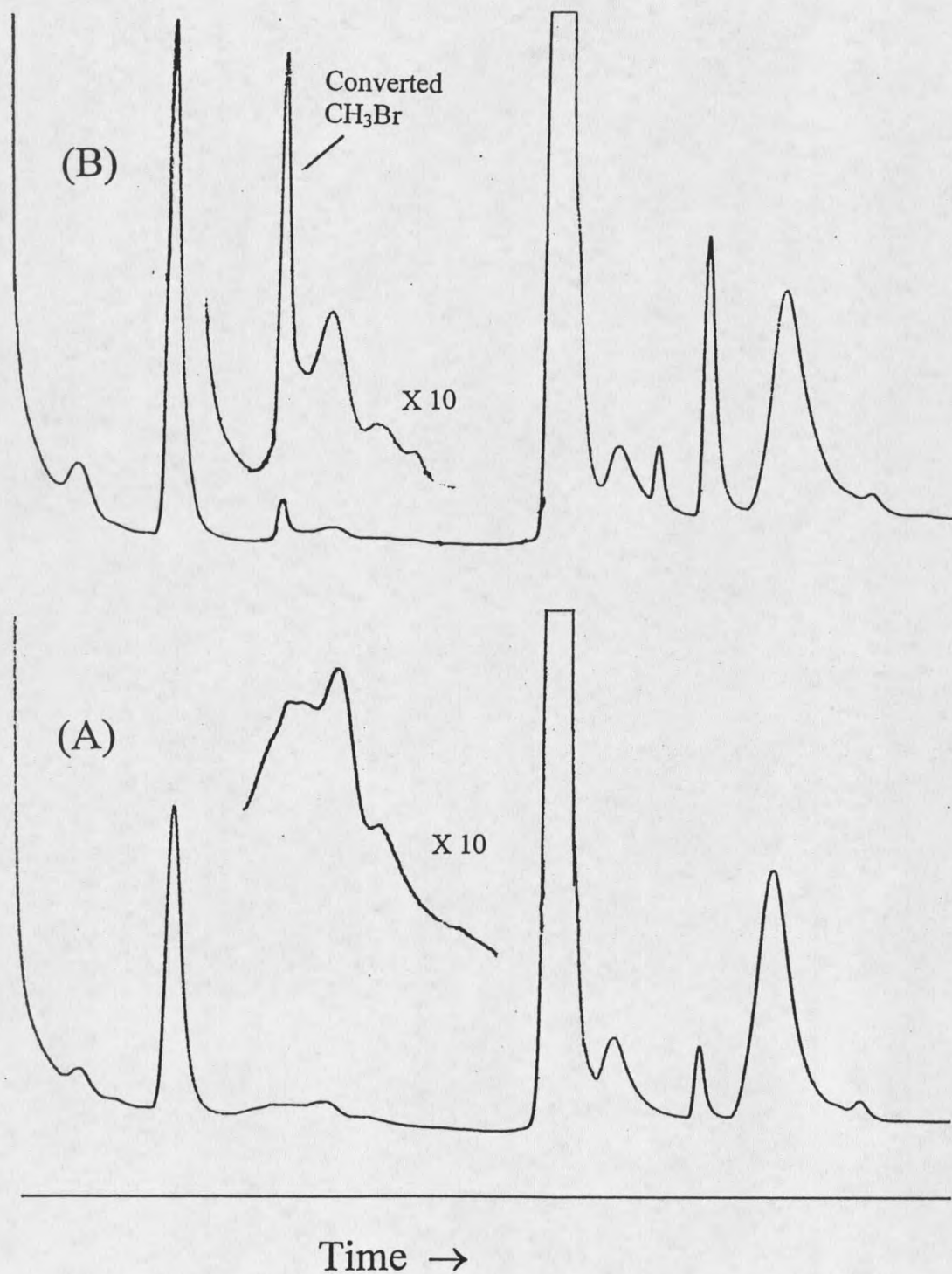

Figure 19. Chromatograms of whole air utilizing optimized conditions. (A) Bypass mode; (B) Through column mode

elution times without sacrificing peak separation. The final temperature had significant impact on separation especially in conjunction with fast ramp rates. Final temperatures below 70°C produced elution times that were exceedingly long. Final temperatures above 150°C lead to coelution problems. A final temperature of 80°C gave adequate separation and reasonable elution times for the methyl iodide product. It was noticed, however, that several peaks that eluted after methyl iodide had very long elution times at final temperatures this low. Since these peaks were not of primary concern, a second ramp of 80°C/min to a final temperature of 150°C was utilized to minimize their elution times and to shorten the overall analysis time. The final temperature program, which gave good methyl bromide separation from surrounding elutants as well as a reasonable run time is as follows:

- Starting Temperature - +20°C
- Hold at 20°C for 3.5min; switch bypass valve to through column mode; continue to hold at 20°C for another 1.5min;
- Ramp from 20°C to 80°C at 80°C/min; Hold for 7min;
- Ramp from 80°C to 150°C at 80°C; Hold for 20min.

Figure 19 shows an example of the chromatography achieved for a 45 ml whole air sample utilizing the above temperature program.

Determination of Peaks of Atmospheric Significance

The chromatogram of whole air shown in Figure 19 illustrates the fact that there are many EC active compounds in the atmosphere. An attempt to identify several

halogenated compounds that are known to have relatively high background concentrations such as Freon-11 and Freon-12 was performed. By identifying the peaks of some of the major halocarbons it may be possible to use these peaks as internal standards and gauges of general system performance because these compounds have well established atmospheric concentrations and are not effected by the conversion process. Peaks that had elution times similar to that of methyl iodide were also scrutinized in an attempt to determine if they might be potential interference problems.

A 4.5-L sample carboy of nitrogen was made up and 100ul headspace vapor for each of the compounds CH_2Cl_2 , CF_2Cl_2 , CFCl_3 , CH_3I , CHF_2Cl , CF_3Br , $\text{C}_2\text{H}_5\text{Cl}$, CH_3Cl and CF_2ClBr was successively added to the carboy. After each compound was introduced, the carboy was allowed to equilibrate for 15 minutes. A sample from the carboy was diluted with nitrogen and introduced into the system. As each sample was run, the peaks were identified and their retention times recorded. Samples were run in both bypass and through column mode to ensure that retention times for both starting material and product were obtained. Whole air samples were spiked with the prepared sample for final confirmation of the identity of peaks. Figure 20 shows a chromatogram of whole air with the peaks due to these compounds identified. The order of elution that was observed for the peaks in Figure 20 is CF_3Br , CF_2Cl_2 , CH_3Cl , CF_2ClBr , $\text{C}_2\text{H}_5\text{Cl}$, CFCl_3 , CH_3I and CH_2Cl_2 . It was determined that CF_2Cl_2 and CH_3Cl coelute when using the above temperature program. Attempts to separate these two peaks met with limited success. The peak corresponding to CHF_2Cl was not identified. $\text{C}_2\text{H}_5\text{Br}$, not listed above, was tested separately and it produced multiple peaks in both bypass and through

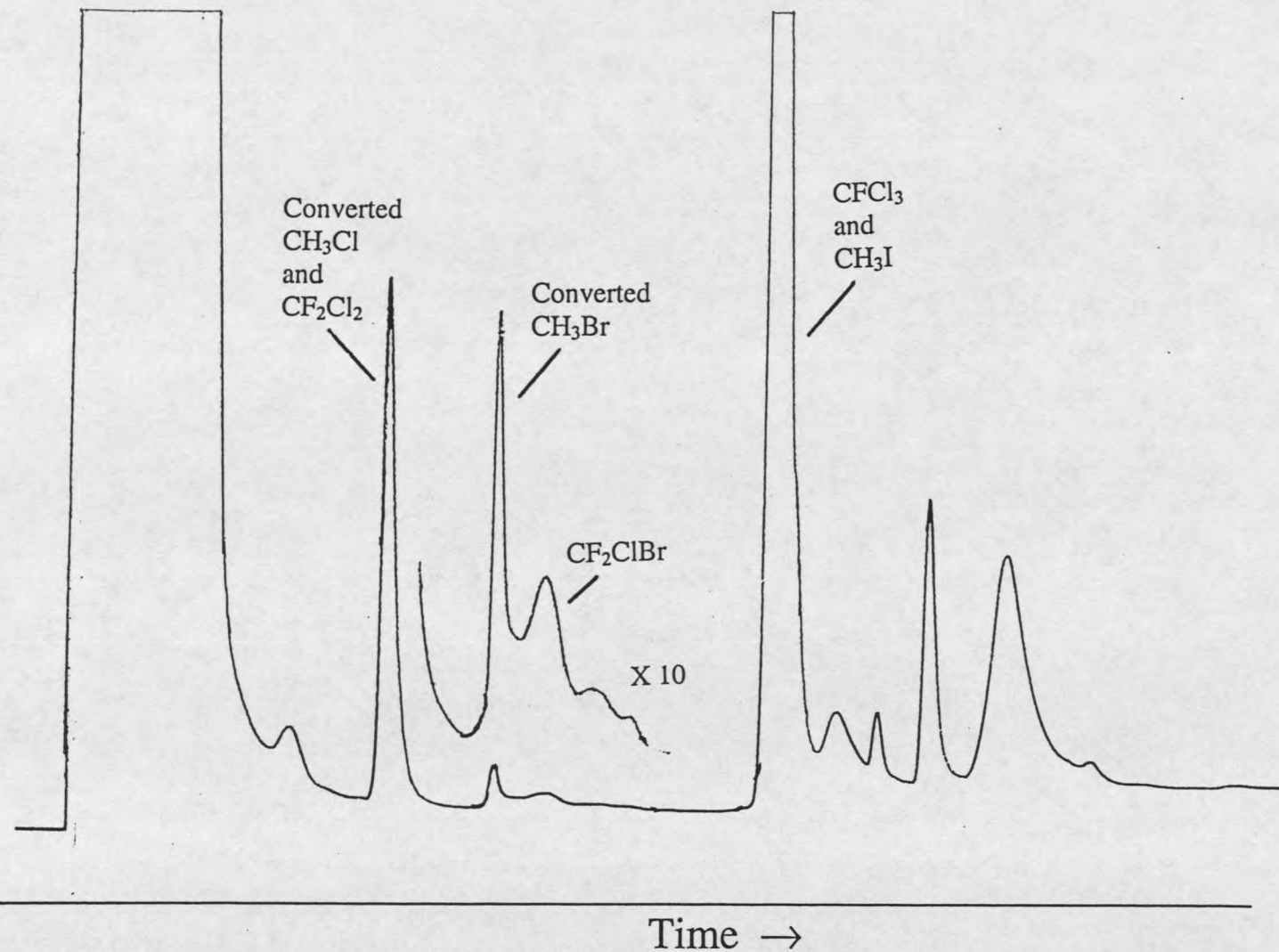

Figure 20. Chromatogram of whole air with some of the major peaks identified.

column mode. No attempt was made to remedy this problem and therefore C_2H_5Br 's retention time was not definitively identified.

Conditions for Optimum Response

The conditions in the table listed below were determined based on the research presented. These conditions were used for the remainder of the study as they provided adequate separation of the methyl iodide product from other atmospheric components and allowed for a reasonable run time.

Table 8. Instrumental conditions for optimum conversion of atmospheric methyl bromide to methyl iodide with subsequent separation from atmospheric components

Carrier Gas	Standard Grade Nitrogen dried with molecular sieve, Drierite, $MgClO_4$
Flow rate of carrier gas	25 to 30 ml/min
Sample size	45 ml
Conversion Column Temperature	150°C
Oven Temperature Program	20°C Start; Hold for 3.5min; Switch Bypass valve to Through column mode; Hold for 1.5min; Ramp from 20°C to 80°C at 80°C/min; Hold for 8min; Ramp from 80°C to 150°C at 80°C; Hold for 20min.
Detector	HP 5890 ^{63}Ni ECD
Detector Temperature	300°C
Chromatographic Column	30m GS-Q
Secondary Separation/Guard Column	1m 10%SF-96 on Chromasorb-W

Reproducibility and Quantitation

This technique for the determination of atmospheric levels of methyl bromide is a unique method for the qualitative determination of methyl bromide, however, many of the techniques discussed in the introduction would work equally well in this capacity. The true value of this technique is its potential to enable quantitative determination of

atmospheric concentrations of methyl bromide on a real time scale, in field locations and over long periods of time.

Reproducibility of the Conversion of Methyl Bromide to Methyl Iodide in Whole Air

Reproducibility was evaluated by repeatedly monitoring the methyl bromide response from a single sample. Figure 21 shows the peak height response observed, represented by "□" in the figure, for methyl bromide over a 20 day period. The sample was collected in a 4.5-L stainless steel container at a location approximately 2.5 miles from Bozeman. The mean peak height, 79.8 mm, and standard deviation, $\pm 3.5\%$, for this data are also shown and are represented in the figure the horizontal lines (.....) and (----) respectively.

Figure 21 also shows the methyl bromide response obtained for a variety of air samples that were collected and analyzed both before and after the above experiment. Indoor air samples, indicated by "X" in the figure, were collected from within the laboratory. Outdoor air samples were collected through a third floor window in the chemistry building, indicated by "o", and from approximately 75 yards east of the chemistry building, indicated by "Δ". The observed response due to methyl bromide in samples that were collected from the window and from outside of the chemistry building showed reasonable similarity to the response observed from the remote sample discussed above indicating that the response due to methyl bromide in a single outdoor air samples can be expected to represent background levels of methyl bromide. However, the

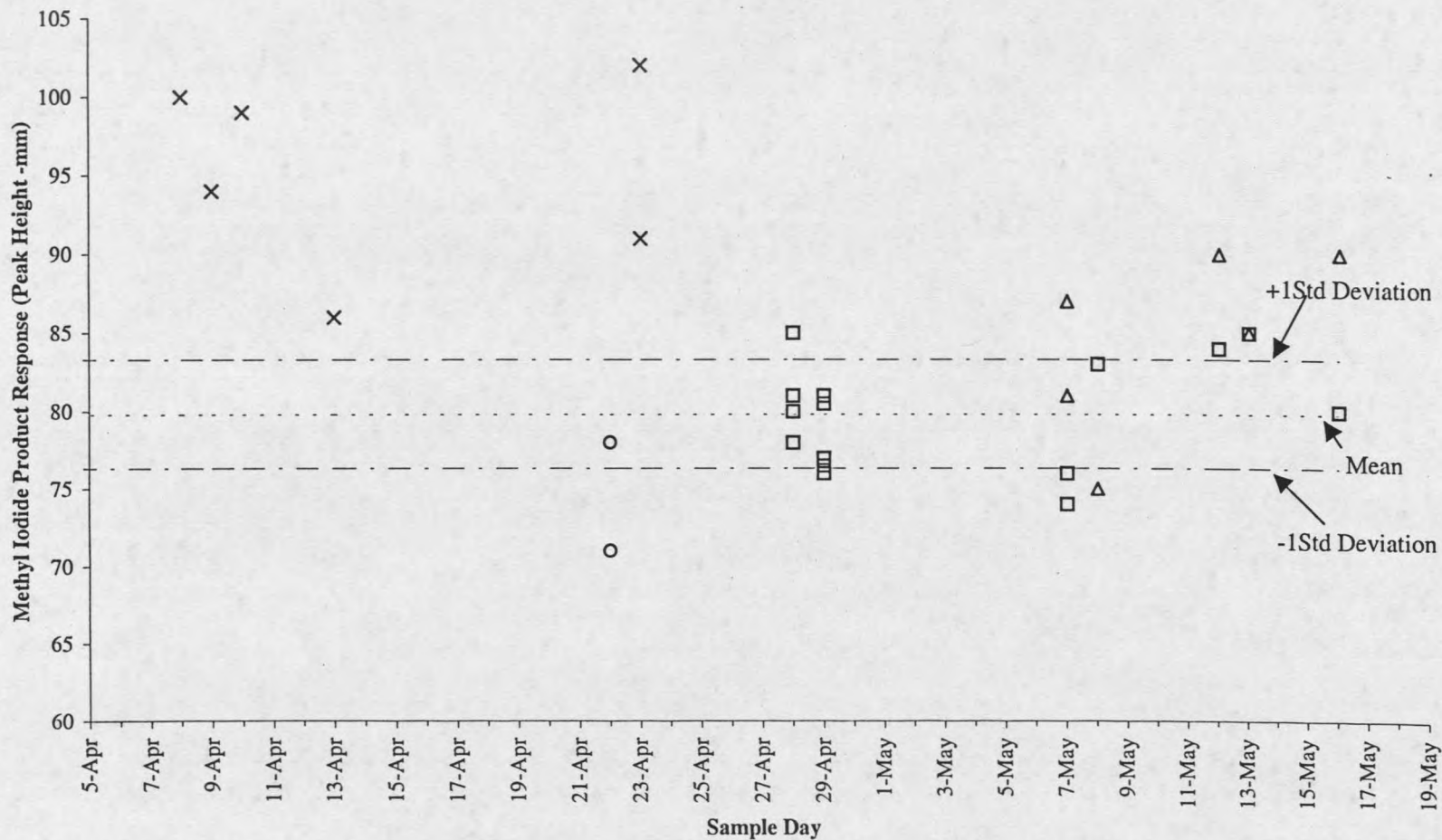

Figure 21. Methyl iodide product response vs. Sample Day. (□) Repeated testing of a sample taken in a 4-L stainless steel container, filled 4/28/98 at a rural location approximately 2.5 miles from Bozeman, MT ; (····) and (·-·-·) represent the mean and standard deviation for this data; (X) Separate indoor air samples taken in the lab by syringe; (△) Separate outdoor air samples taken by syringe on MSU campus (o) Separate outdoor air samples taken by syringe through a 3rd floor window, Gaines Hall MSU.

response due to methyl bromide that was observed for samples taken from within the laboratory showed a somewhat elevated response. This response was anticipated due to the use of methyl bromide within the chemistry building.

Verification and Calibration

It has been shown that the conversion of methyl bromide to methyl iodide is reproducible. As such, an attempt to determine absolute atmospheric concentrations of methyl bromide utilizing the conversion technique was undertaken but proved to be difficult due to the instability of methyl bromide standards in the low ppt range.⁵² In an attempt to circumvent this problem, Dr. John Culbertson, a postdoctoral fellow in the Grimsrud group, constructed an apparatus that would enable the generation of low concentrations of volatile compounds. Essentially a 1.8-m x 3.6-m metal pipe is capped on both ends thereby making a 9600-L carboy. Through the use of this apparatus and standard addition techniques, a determination of atmospheric concentrations is possible by using the following procedure. A standard of the compound of interest is made at the part per million in a 20-L carboy as described in the experimental section. Standards prepared at this level of concentration do not exhibit the instability problems associated with low concentration standards. A sample of the air inside and outside of the 9600-L carboy is taken in separate sampling canisters. A volume from the 20-L carboy is injected into the 9600-L carboy. The volume is mixed for 10 min. utilizing a large hand crank fan that is inserted into the side of the metal pipe. The system is then allowed to rest for 40 min. After the rest period, a sample from inside the carboy is taken and another sample from the 20-L carboy is injected into the pipe. This process is repeated until a total of 3 to 5 additions have been made into the 9600-L volume. Samples are

then taken back to the lab and analyzed. The resultant peak heights for the compound of interest are measured for each of the samples. A plot of added concentration, based on the concentration of the standard in the 20-L carboy, versus peak height is plotted and provided a linear calibration curve is obtained, the x-intercept provides the atmospheric concentration. This system was not developed for use on this project and was in constant use by Dr. Culbertson during the duration of this project. However, one opportunity to use this apparatus was made available.

A 20-L carboy was made up to a concentration of 139 ppm. A total of three, 1-ml volumes were injected into the 9600-L volume using the protocol described above. A sample from the sampling canister was introduced into the system, the response due to the methyl iodide product was monitored, and the peak height was recorded. Each of the five canisters was tested three times. Figure 22 shows the plot of methyl iodide product response vs. concentration for this experiment. Data from this experiment indicates that the concentration of methyl bromide in rural Montana air is 16 pptv, compared to the accepted global average of 10 pptv. One known error was made during the sampling process, the sampling port was left open between the first and second sampling, which allowed spiked air from within the 9600-L volume to exchange with outside air. This invalidates the data with regard to its use as a quantitative calibration but it does demonstrate that the peak in question is undoubtedly methyl iodide and that this technique holds promise for future calibration attempts. Note also that by lowering the concentration in the 9600-L carboy, it would be anticipated that the value obtained for the

atmospheric concentration would be high. Calibration of the system appears to be possible but the opportunity to reproduce this experiment has not been afforded.

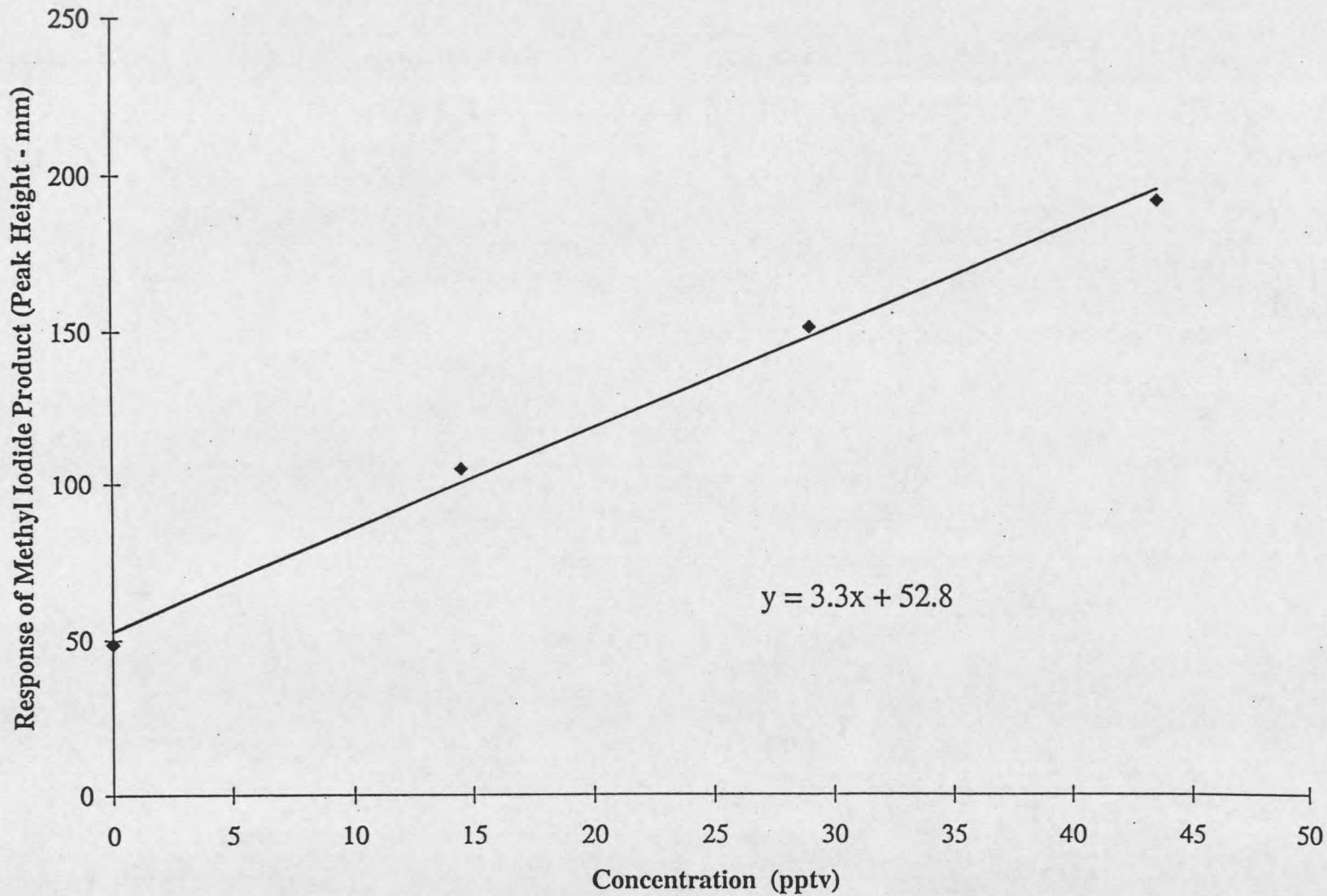

Figure 22. Plot of methyl iodide product response vs. concentration for 3 1-ml samples (139 ppm) that were successively added to a 9600-L volume of whole air.

CONCLUSION

It has been demonstrated that conversion of methyl chloride to methyl iodide utilizing an inline sodium iodide column, as described by Watson and Ooman, was reproducible. Although we were unsuccessful at operating the conversion column at the high temperatures utilized by the other authors, conversion using a sodium iodide column was clearly evident at 150°C, but was quite inefficient. It was found that several other metal iodide salts provided much better conversion of methyl chloride to methyl iodide than sodium iodide did at these lower conversion column temperatures. Most notable of these are lithium iodide and magnesium iodide, which at 150°C were 53 and 50 times better than sodium iodide at converting methyl chloride to methyl iodide, respectively.

The conversion of methyl bromide to methyl iodide was demonstrated for the first time and was observed to be more efficient than the methyl chloride conversion for all of the salts tested. Zinc iodide at 150°C was shown to be the metal iodide of choice in that it promoted an 82% conversion of methyl bromide to methyl iodide. Use of 150°C column temperatures minimized column bleed and ensured that the use of the ECD would be possible. Lithium iodide also converted methyl bromide to methyl iodide efficiently, 78%, but was not as selective for the conversion of methyl bromide as zinc iodide. This was shown later in the study to not be of great concern and as such, lithium iodide might be considered in future studies.

A number of phase transfer catalysts were used in conjunction with zinc iodide in an attempt to improve the conversion efficiency and lower the conversion column

operating temperature. The results showed that 100% conversion of methyl bromide to methyl iodide could be achieved at 125°C with the use of a column containing tetrabutylammonium iodide or tetrabutylphosphonium iodide mixed with zinc iodide and Chromasorb-W. However, the use of temperatures over 125°C indicated that column bleed would likely have been problematic and temperatures of at least 100°C were necessary to achieve results similar to those utilizing the zinc iodide only column. Since modest temperature gain and increased column bleed indicated that no significant benefit would be achieved through the use of these columns, further study was not pursued.

Thirty-four halogenated organic compounds were tested to determine if they could be converted to iodinated analogs utilizing a zinc iodide conversion column. However, the only compounds of significant atmospheric interest that converted were methyl chloride and methyl bromide and 1,1,1-trichloroethylene. All of the primary alkyl halides tested converted to the corresponding alkyl iodide. Two conversion products were observed for secondary alkyl halides. One product was deduced to be an alkene due to halide elimination and the other product was presumably the alkyl iodide. Compounds with multiple halogens did not convert to iodo compounds except in limited cases and those that contained fluorine, most noticeably the Freons, did not convert at all. This may prove to be useful if these unconverted compounds can be utilized as internal standards in the determination of methyl bromide in whole air. Also, since compounds such as the Freons do not convert, there are fewer conversion products to interfere with the detection of methyl bromide. However, it would have been scientifically beneficial to increase the detection limit of some of the halogenated hydrocarbons in order to track the changes in

concentration as new governmental policies dictate their use and to possibly improve the detection of some of the new refrigerants that are replacing Freon-11 and Freon-12.

The use of the tritium ECD was studied in the hope that significant improvement due to the response of methyl iodide would be observed. The presence of water vapor in the ECD cell proved to be necessary in order to obtain the maximum response to methyl iodide. A make up gas of wet nitrogen was used to deliver water vapor to the cell. For any given concentration of methyl iodide, the response of tritium ECD outperformed the ^{63}Ni by 85%. However, better signal to noise was achieved on the HP5890 ^{63}Ni ECD most likely due to more refined commercial electronics.

Detection of methyl bromide in 45-ml whole air samples has been achieved. The use of a 45-ml sample, although unconventional when using a capillary column, proved to be an important key to the enhancement of the converted methyl bromide. However, the increased sensitivity gained by converting methyl bromide to methyl iodide is what really made this technique viable. By converting methyl bromide to methyl iodide, it has been demonstrated that responses for the converted methyl bromide can have S/N ratios of better than 150:1.

The reproducibility of this technique was demonstrated by gathering data from several locations over a two month period. Thirty-five samples were compared and 95% of the data showed a standard deviation of $\pm 11\%$. It is believed that several of these samples showed elevated values due to the location or condition of sampling. If this data is discounted 26 samples show a standard deviation of $\pm 6\%$.

Quantitation of atmospheric levels of methyl bromide was only attempted once utilizing standard addition techniques and a unique 9600-L vessel in conjunction with the conversion process. A concentration of 16 pptv methyl bromide in rural Montana air was determined. However, the integrity of this data is in question due to a mistake made during the standard addition procedure. The average concentration of methyl bromide is accepted to be 10 ppt. The standard addition procedure did demonstrate, however, the viability of quantitating atmospheric concentrations of methyl bromide through the utilization of the methods described in this thesis.

LITERATURE CITED

- ¹ World Meteorological Organisation, *Atmospheric Ozone:1985*. Global Oxone Research and Monitoring Project; WMO, Geneva, 1986; Report No. 16
- ² *Environmental Chemistry*; Bunce, Nigel J.;Wuerz Publishing, Winnipeg Canada, 1990
- ³ World Meteorological Organisation, *Scientific Assessment of Stratospheric Ozone: 1989*. Global Ozone Research and Monitoring Project; WMO, Geneva, 1990; Report No. 20
- ⁴ Chapman, S., *Mem. Roy Meteorol.Soc.* 3, 103 (1930)
- ⁵ World Meteorological Organisation, *Scientific Assessment Ozone Depletion: 1994*. Global Ozone Research and Monitoring Project; WMO, Geneva, 1995; Report No. 37
- ⁶ Dobson, G. M. B. *Applied Optics* 1968, 7(3), 387-405
- ⁷ Rowland, F.S.; Molina M. J. *Nature* 1974, 249, 810
- ⁸ Farman, J. C.; Gardiner, B. G.; Shanklin, J. D. *Nature* 1985, 315, 207
- ⁹ Gardiner, B.G. *Geophysical Research Letters* 1988, 15, 901
- ¹⁰ Hoffman, D.J.; Harder, J.W.; Rosen, J. M.; Hereford, J.V.; Carpenter, J.R. *Journal of Geophysical Research* 1989, 94, 16527
- ¹¹ Komhy, W.D.; Grass, R.D.; Reiteibach, P.J.; Kuester, S.E.; Franchois, P.R.; Fanning, M.L. *Journal of Geophysical Research* 1989, 94, 11429
- ¹² EPA Webpage www.epa.gov/ozone/science/hole/size.html
- ¹³ NASA web page http://jwocky.gsfc.nasa.gov/multi/oz_hole_area.gif

- ¹⁴ Anderson, J.G.; Toohey, D.W.; Brune, W.H. *Science* **1991**, 251, 39-46
- ¹⁵ World Meteorological Organisation, *Scientific Assessment Ozone Depletion: 1998 Executive Summary*. Global Ozone Research and Monitoring Project; WMO, Geneva, 1998
- ¹⁶ Brune, W.H.; Anderson, J.G.; Toohey, D.W.; Fahey, D.W.; Kawa, S.R.; Jones, R.L.; McKenna, D.S.; Poole, L.R. *Science*, **1991**, 252, 1260-1266
- ¹⁷ Turco, R.; Plumb, A.; Condon, E. *Geophysical Research Letters*, **1990**, 17, 313
- ¹⁸ S. F. Singer web page <http://www.sepp.org>
- ¹⁹ Deshler, T.; Hofmann, D.J.; Heareford, J.V.; Sutter, C.B. *Geophysical Research Letters* **1990**, 17, 151
- ²⁰ Berg, W. W.; Heidt, L. E.; Pollock, W.; Sperry, P. D.; Cicerone, R. J.; Gladney, E. S. *Geophysical Research Letters* **1984**, 11, 429 - 432
- ²¹ Wofsy, S.C.; McElroy, M.B.; Yung, Y.L. *Geophysical Research Letters* **1975**, 2, 215-218
- ²² Yung, Y.L.; Pinto, J.P.; Watson, R.T.; Sander, S.P. *Journal of the Atmospheric Sciences* **1980**, 37, 339-353
- ²³ Schauffler, S.M.; Atlas, E.L.; Flocke, F.; Lueb, R.A.; Stroud, V.; Travnick, W. *Geophysical Research Letters* **1998**, 25(3), 317-320
- ²⁴ Schauffler, S.M.; Heidt, L.E.; Pollock, W.H.; Gilpin, T.M.; Vedder, J.F.; Solomon, S.; Lueb, R.A.; Atlas, E.L. *Geophysical Research Letters* **1993**, 20(22), 2567-2570

- ²⁵ *The Methyl Bromide Issue* Bell, C.H.; Price, N.; Chakrabarti, B.; John Wiley & Sons, NY, 1996
- ²⁶ Brune, W.H.; Anderson, J.G.; Chan, K.R. *Journal of Geophysical Research* **1989**, *94*, 16639-16647
- ²⁷ Toohey, D.W. Anderson, J.G.; Brune, W.H.; Chan, K.R. *Geophysical Research Letters* **1990**, *17*(4), 513-516
- ²⁸ Solomon, S.; Mills, M. Heidt, L.E.; Pollock, W.H.; Tuck A.F. *Journal of Geophysical Research* **1992**, *97*, 825-842
- ²⁹ United Nations Environmental Programme (UNEP), Report of the Fourth Meeting of the Parties to the Montreal Protocol on Substances that Deplete the Ozone Layer (Copenhagen), New York, 1992
- ³⁰ Yates, S.R.; Gan, J.; Ernst, F.F.; Mutziger, A.; Yates, M.V. *Journal of Environmental Quality* **1996**, *25*, 184-192
- ³¹ Baker, J.M.; Reeves, C.E.; Penkett, S.A.; Cardenas, L.M.; Nightingale, P.D. *Geophysical Research Letters* **1998**, *25*(13), 2405-2408
- ³² Manö, S; Andreae, M.O. *Science* **1994**, *263*, 1255-1257
- ³³ Andreae, M.O.; Atlas, E.; Welling, M. *Journal of Geophysical Research* **1996**, *101*, 23603-23613

- ³⁴ Lobert, J. M.; Butler, J. H.; Geller, L. S.; Yvon, S. A.; Montzka, S. A.; Myers, R. C.; Clarke, A. D.; Elkins, J. W. BLAST 94: Bromine latitudinal air/sea transect 1994, 1996, NOAA Technical Memorandum ERL CMDL-10
- ³⁵ Lobert, J.M.; Yvon-Lewis, S.A.; Butler, J.H.; Montzka, S. A.; Myers, R.C. *Geophysical Research Letters* **1997**, 24(2), 171-172
- ³⁶ Shorter, J.H.; Kolb, C.E.; Crill, P.M.; Kerwin, R.A.; Talbot, R.W.; Hines, M.E.; Harriss, R.C. *Nature* **1995**, 377, 717-719
- ³⁷ Kerwin, R.A.; Crill, P.M.; Talbot, R.W.; Hines, M.E.; Shorter, J.H.; Kolb, C.E.; Harriss, R.C. *Analytical Chemistry* **1996**, 68(5), 899-903
- ³⁸ Lee-Taylor, L.M.; Doney, S.C.; Brasseur, G.P. *Journal of Geophysical Research* **1998**, 103(D13), 16039-16057
- ³⁹ Butler, J.H.; Montzka, S.A.; Clarke, A.D.; Lobert, J.M.; Elkins, J.W. *Journal of Geophysical Research* **1998**, 103(D1), 15.3-1511
- ⁴⁰ Bassford, M.R.; Simmonds, P.G.; Nickless, G. *Analytical Chemistry* **1998**, 70, 958-965
- ⁴¹ Grimsrud, E.P. in *Electron Capture: theory and practice in chromatography* Journal of Chromatography Library, Vol 20, Zlatkis, A.; Poole, C.F. Editors, Elsevier Scientific Publishing Company, Amsterdam, The Netherlands, 1981, Chapter 5.
- ⁴² Watson, A.J.; Ball, G.L.; Stedman, D.H. *Analytical Chemistry* **1981**, 53(1), 132-134
- ⁴³ Tundo, P. *Gazzetta Chimica Italiana* **1990**, 120, 69 - 76

- ⁴⁴ Maggs, R.J.; Joynes, P.L.; Davies, A.J.; Lovelock, J.E. *Analytical Chemistry* **1971**, 43(14), 1966-1971
- ⁴⁵ Zlatkis, A.; Poole, C.F. *Analytical Chemistry* **1980**, 52(9), 1002A-1016A
- ⁴⁶ Oomens, A.C.; Noten, L.G. *Journal of High Resolution Chromatography & Chromatography Communications* **1984**, 7, 10485-10486
- ⁴⁷ Comprehensive Organic Transformations: A guide to functional group preparations
Larock, Richard C., VCH Publishers Inc., N.Y. 1989, pp 337-339
- ⁴⁸ Tundo, P.; Venturello, P. *Synthesis* **1979**, 952-954
- ⁴⁹ *Mechanism and Theory in Organic Chemistry* Lowery, T.H.; Richardson, K.S., 3rd Ed.
Harper & Row Publishers, N.Y, 1987, Chapter 4
- ⁵⁰ Grimsrud, E.P.; Knighton, W.B. *Analytical Chemistry* **1982**, 54(3), 565-570
- ⁵¹ Arbon, R.E.; Grimsrud, E.P. *Analytical Chemistry* **1990**, 62(17), 1762-1768
- ⁵² *Survey and Analysis of Halogenated Compounds in the Atmosphere by Gas Chromatography/High Resolution Mass Spectrometry* Engen, M.A., Doctoral Thesis, Montana State University, August 1997

MONTANA STATE UNIVERSITY - BOZEMAN



3 1762 10421252 5