



Temperature controls for radiant heating with floor panels  
by James E Hurtle

A THESIS submitted to the Graduate Faculty in partial fulfillment of the requirements for the degree of  
Master of Science in Mechanical Engineering  
Montana State University  
© Copyright by James E Hurtle (1952)

Abstract:

There are a great many controls manufactured for radiant heating with floor panels. these controls have a price range from \$22.20 for a 110-volt room thermostat controlling the circulator pump to \$257.00 for an indoor-outdoor control that mixes return water with the "boiler water to give a water temperature to the panel that varies with outdoor tenpera-tune. For this thesis, a study was made and test conducted to determine if expensive controls are necessary and to determine which controls give the best results.

From the test results the following conclusions were made: 1. None of the controls tested are satisfactory for radiant heat with floor panels.

2. The simple bimetal type 110-volt thermostat Controlling the Circulator gives as good results as any of the other control systems tested and it is the least expensive system.

TEMPERATURE CONTROLS FOR RADIANT HEATING  
WITH FLOOR PANELS

by

JAMES E. HURBLE

A THESIS

Submitted to the Graduate Faculty

in

partial fulfillment of the requirements

for the degree of

Master of Science in Mechanical Engineering

at

Montana State College

Approved:

  
Head, Major Department

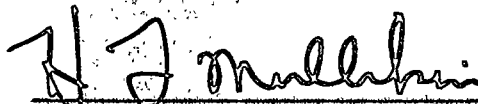
  
Chairman, Examining Committee

  
Dean, Graduate Division

Bozeman, Montana  
June, 1952

N 378  
H 948t  
Cop. 2

TABLE OF CONTENTS

Abstract . . . . .	5
Chapter I, Control System Components	
Introduction . . . . .	6
Room Thermostats:	
Low-Voltage Room Thermostat . . . . .	7
Minneapolis-Honeywell Three-Wire Low-Voltage Thermostat . . . . .	8
110-Volt (Line-Voltage) Thermostat . . . . .	9
Mercoird Thermostat . . . . .	11
Fenwal Thermoswitch . . . . .	11
Thrush Radiant Heat Thermostat . . . . .	13
Sarcotherm Thermoray . . . . .	15
Day-Night Thermostat . . . . .	16
Relays:	
Two-Wire Relay . . . . .	18
110-Volt Relay . . . . .	20
Three-Wire Relay . . . . .	20
Immersion Thermostats:	
Bimetal Type . . . . .	23
Hydraulic Type . . . . .	23
Gas Valves:	
Solenoid Operated . . . . .	25
Diaphragm Operated . . . . .	25
Hydraulically Operated . . . . .	25
Heat Motor Operated . . . . .	25

<b>Safety Controls:</b>	
Safety Pilot . . . . .	29
Stack Switch . . . . .	31
Stoker Timer . . . . .	33
<b>Water Valves:</b>	
Motor-Operated Valve . . . . .	33
Solenoid-Operated Valve . . . . .	34
Heat-Motor Valve . . . . .	34
<b>Controls Used With Tankless Or Direct Domestic Water Heaters:</b>	
Reverse-Acting Immersion Thermostat . . . . .	35
Thermostatic Flow-Check Valve . . . . .	35
Thermostatic Three-Way Valve . . . . .	35

Chapter II. Control Circuits

Introduction . . . . .	38
<b>Indoor Control Systems:</b>	
<b>Intermittent Circulation:</b>	
Low-Voltage . . . . .	40
110-Volt (Line Voltage) . . . . .	43
<b>Continuous Circulation:</b>	
Low-Voltage . . . . .	43
110-Volt . . . . .	43
Tankless Direct Domestic Hot Water Circuits . . . . .	43
<b>Indoor-Outdoor Circuits:</b>	
Sarcotherm Indoor-Outdoor Modulating Mixing Valve . . . . .	43

White-Rogers Indoor-Outdoor Burner Control . . . . .	51
Control of Length and Frequency of Cycle of Heating System:	
Minneapolis-Honeywell Electronic Moduflow . . . . .	58
Zone Control . . . . .	60
Chapter III. Control Tests	
Introduction . . . . .	65
Purpose . . . . .	66
Control Cost and Power Requirement Tests . . . . .	66
Tests Conducted In:	
Radiant Heating Laboratory . . . . .	69
David Wessel Residence and Danforth Chapel . . . . .	86
Conclusions . . . . .	93
Discussion . . . . .	93
Literature Consulted . . . . .	94

ABSTRACT

There are a great many controls manufactured for radiant heating with floor panels. These controls have a price range from \$22.20 for a 110-volt room thermostat controlling the circulator pump to \$257.00 for an indoor-outdoor control that mixes return water with the boiler water to give a water temperature to the panel that varies with outdoor temperature. For this thesis, a study was made and test conducted to determine if expensive controls are necessary and to determine which controls give the best results.

From the test results the following conclusions were made:

1. None of the controls tested are satisfactory for radiant heat with floor panels.
2. The simple bimetal type 110-volt thermostat controlling the circulator gives as good results as any of the other control systems tested and it is the least expensive system.

## Chapter I

### CONTROL SYSTEM COMPONENTS

#### Introduction

Chapter I consists of the following topics:

Room Thermostats

Relays

Immersion Thermostats

Gas Valves

Safety Controls

Water Valves

Controls Used with Tankless Domestic Water Heaters

The controls described under these topics represent a cross-section of the types available at the present time. The descriptions are based on information provided by the manufacturers and visual inspection of the controls.

Special indoor-outdoor controls that vary heat input to the system depending on outdoor temperature are described in Chapter II as complete systems.

Room Thermostats

Low-Voltage Room Thermostat

The function of a room thermostat is to maintain the air in a room at a desired temperature. By low-voltage thermostat, it is meant that the thermostat energizes a relay which in turn closes suitable contacts to satisfactorily handle the full load of the circuit. A typical example of this type of control is shown in Figure 1.

The primary control element consists of a bimetal (A). As the room approaches the desired temperature the bimetal moves in the direction shown and the electrical contacts are broken.

The temperature at which the control breaks the contacts is adjusted by controlling the distance the bimetal is from the fixed contacts (B). This is accomplished by the cam arrangement (C).

With the simple room thermostat described, there would be a considerable lag and overrun of room temperature. This is because the bimetal will not reach the temperature at which it is set until the room has already become warm. The same effect occurs upon cooling. The room becomes cool before the bimetal. To overcome this difficulty, leading control manufacturers include a heat anticipating feature. This consists of a resistance (D) in series with the contacts. Then when the contacts

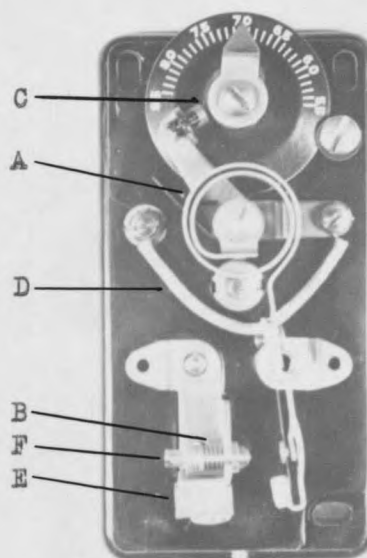

Penn Low-Voltage  
Thermostat  
Figure 1

are closed there is a current flowing through the resistance wire. This creates heat which causes the bimetal to break the contacts two or more degrees before the room temperature is up to the desired level. By doing this, the overrun effect is partially compensated for. Since the bimetal is then at a higher temperature than the room, it cools and closes the contacts before the room temperature drops appreciably, thereby eliminating some lag.

Another desirable feature of the control illustrated is the small permanent magnet (E). This gives snap action to the contacts both on make and break, thereby prolonging their life.

The differential of a control is the difference between the point at which the contacts open and close. It is adjusted by the movable contact (F). This adjustment usually has a range of from 1°F to 5°F differential.

#### Minneapolis-Honeywell Three-Wire Low-Voltage Thermostat

This control differs from the thermostat already described in that the heating element (A) in Figure 2 is not in series with the contacts. Instead it is in parallel with contacts (B). By using this arrangement, when the thermostat is calling for heat and the contacts are closed the heating resistor is shunted so that it does not supply heat. As the room approaches the desired temperature, contact (B) opens first. When this contact opens current flows through the heating element and adds heat until contact (C) is broken. The system is then shut down.

The advantage claimed for this type of control is that at the

start of the cycle the resistance element has no effect and the heating system that it is controlling will be on until the generated heat is beginning to be felt throughout the enclosure. Then the contact (B) opens and the resistance element (A) adds heat and shuts the system down. This eliminates some lag and overrun as well as allowing a longer cycle in severe weather.

#### 110-Volt (Line Voltage) Thermostat

The 110-volt thermostat controls the circuit directly with the contacts in the thermostat within the current limits of the control.

A bimetal type is shown in Figure 3. The operation of this control is the same as that in Figure 1. By comparing the two figures, it may be seen that the 110-volt thermostat has heavier contacts and therefore a correspondingly heavier bimetal. This added weight of parts tends to make the 110-volt thermostat less sensitive than the low-voltage thermostat.

Another type of 110-volt thermostat is shown in Figure 4. This control is actuated by a bellows instead of a bimetal. The bellows contains a limited charge of liquid and vapor. The charge is such that the pressure exerted in the bellows for any temperature that the control will

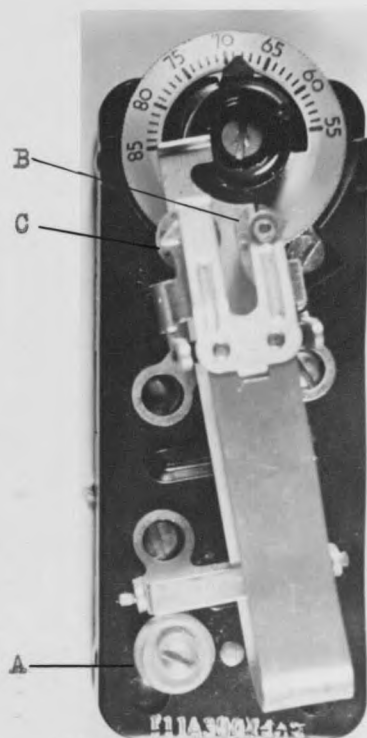

Minneapolis-Honeywell  
Three-Wire Low-Voltage  
Thermostat  
Figure 2

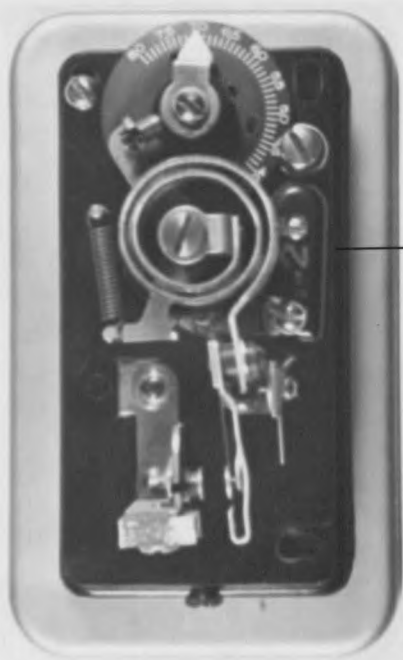

Heater

Penn 110-Volt  
Thermostat  
Figure 3

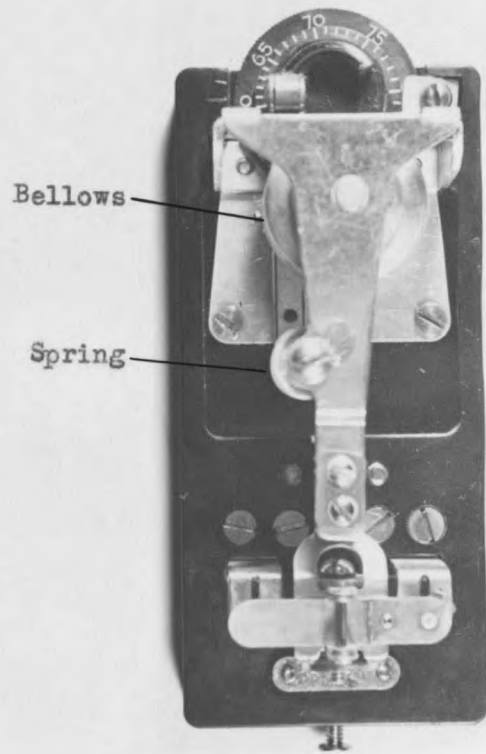

Bellows

Spring

Perfex 110-Volt  
Thermostat  
Figure 4

operate is a straight-line function. Methyl chloride is a typical substance used for this.

By limited charge it is meant that liquid and vapor exist in the bellows at all times. As the temperature increases, more liquid will vaporize and will cause a pressure increase corresponding to the saturation pressure for that particular temperature.

This force exerted by the bellows is then balanced by a spring. The temperature at which the control operates is adjusted by increasing the spring tension to raise the temperature and decreasing the spring tension to lower the temperature. This type of control, like the bi-metal type, has an inherent differential. A minimum differential of  $1^{\circ}\text{F}$  may be obtained by careful selection of spring and bellows.

#### Mercoid Thermostat

This control (Figure 5) consists of a bimetal (A), a permanent magnet (B) and a mercury switch (C). It may be seen from Figure 6 that when the thermostat is calling for heat the magnet moves close to the glass covering of the mercury switch. This causes the armature (A) to move toward the magnet. The electrode (E) then enters the mercury pool (D) and completes the circuit. Because of the light force required to make contact, this type of control is very sensitive.

#### Fenval Thermo-switch

This control is of unusual design. Its action is derived from the difference in expansion of the outside shell (A), Figure 7, and the

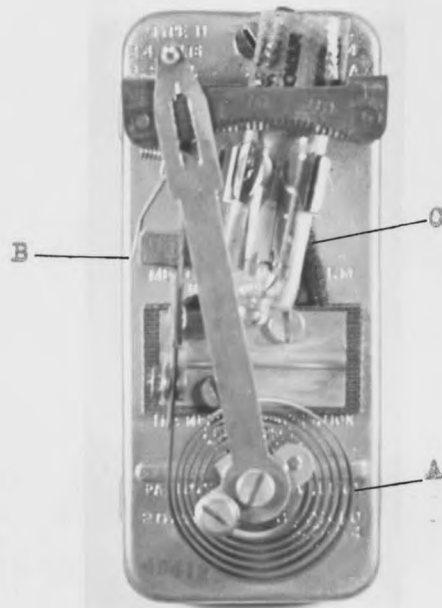

Mercoid Low-Voltage  
Thermostat  
Figure 5

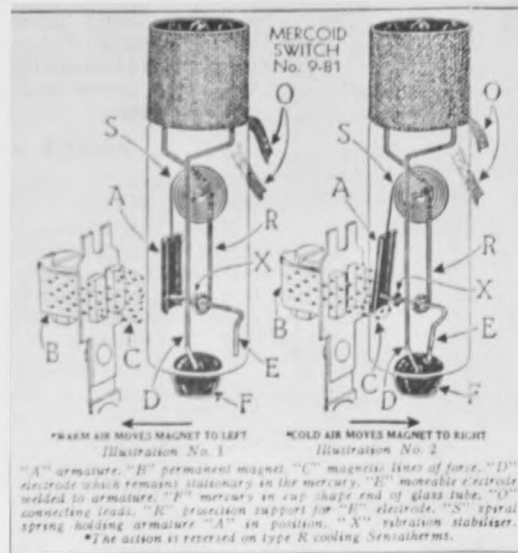

Mercoid Switch Used in  
Mercoid Thermostat  
Figure 6

nickel iron struts of low expansion coefficient (B). When the temperature rises, the outside shell expands. This places tension on the struts (B) which causes them to move apart and break the contacts. The temperature at which the contacts will open is adjusted by the sleeve (C). Turning this sleeve clockwise will increase the tension on the struts and lower the temperature at which the control will operate.

#### Thrush Radiant Heat Thermostat

This thermostat, Figure 8, is actuated by a bellows inside the protective cover. In addition to the room temperature actuating the bellows, there is a capillary tube from the bellows to a remote bulb. This bulb is fastened to a return water line from the room. When the room temperature is below the setting of the thermostat the contacts are closed and the circulator will run until the room reaches the desired temperature. Then the bellows actuated by the room temperature will break the contacts and shut down the system. However, as soon as the water temperature drops in the return line the return water bulb will again start the circulator

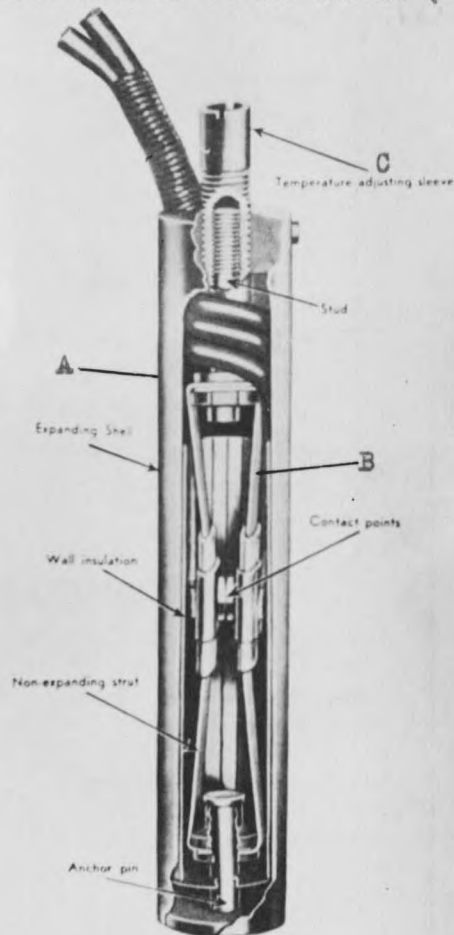

Fenwal Thermostatic Switch  
Figure 7

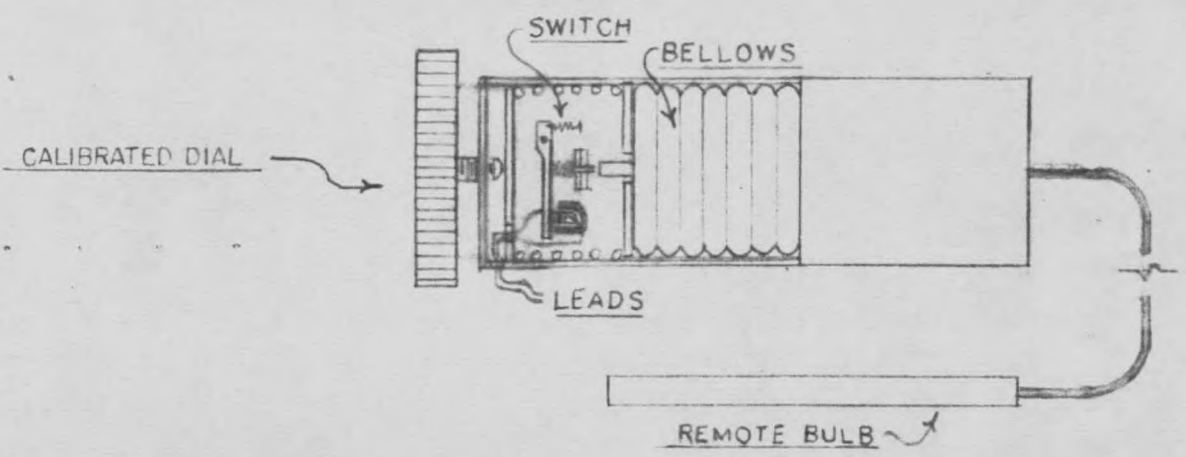

FIG. 8. THRUSH RADIANT HEAT THERMOSTAT

until the water reaches the initial temperature. Since the return water temperature depends on the rate of cooling of the slab which in turn depends on the outdoor temperature, this control is supposed to maintain a water temperature in the slab proportional to the outdoor temperature.

#### Sarcotherm Thermoray

The Sarcotherm Thermoray, Figure 9, is designed to sense radiant heat change as well as air temperature. It consists of a dull black sphere containing a charged bellows (A) that operates a switch (B). A heating element (C) is designed to maintain a 80°F temperature within the sphere when comfort conditions are met. When the combined effect of radiation and air temperature on the outside of the sphere cause the temperature inside the sphere to drop below 80°F the switch operates the heating system to provide more heat.

This control is also manufactured in a flush-type mounting.

#### Day-Night Thermostat

A common type of day-night thermostat is shown in Figure 10. This consists of a bimetal thermostat similar to those already described with a separate night set-back heater (A). The electric clock on the thermostat closes a switch (B) at the time set on the night dial. This causes current to flow through the night set-back heater.

The amount of heat added by the night set-back heater can be adjusted by the set-back indicator (C). This indicator moves a slide across a resistance in series with the set-back heater, and it may be

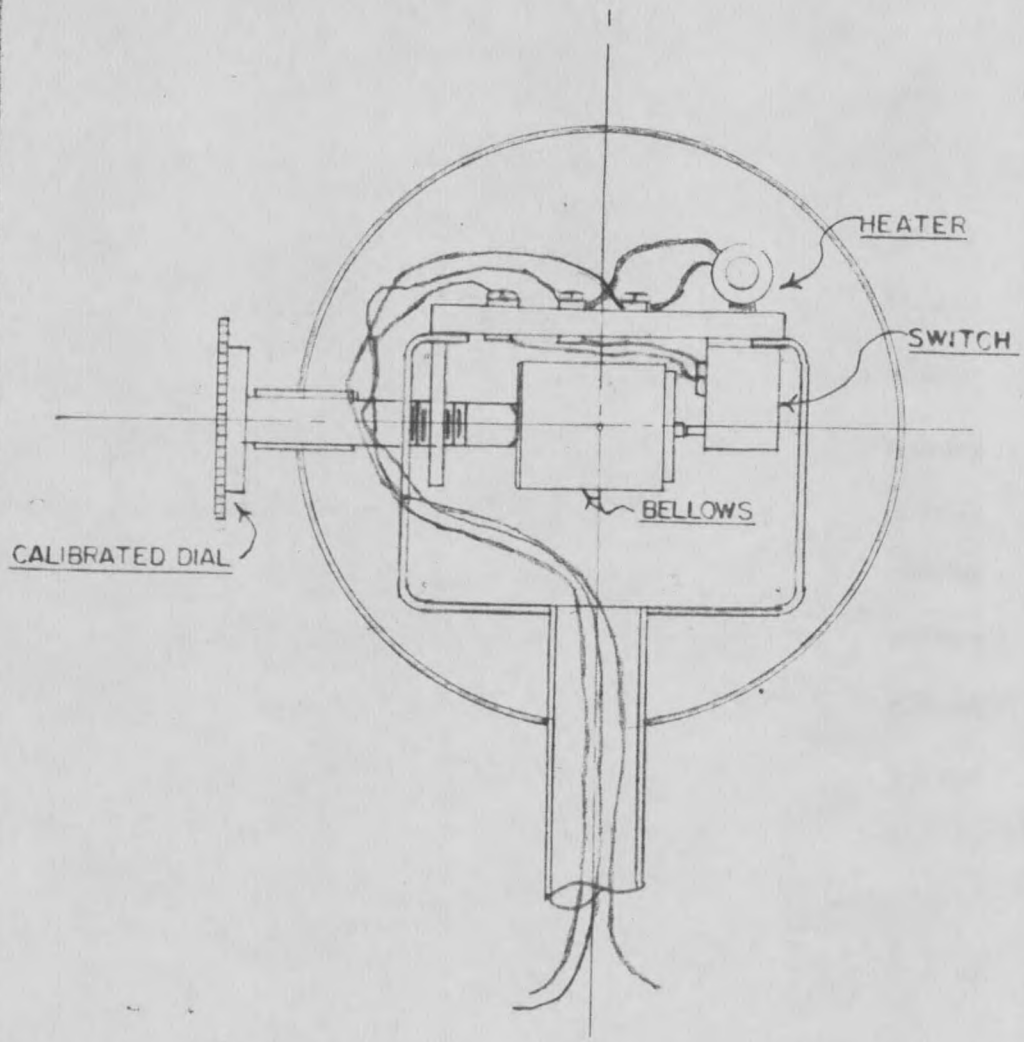
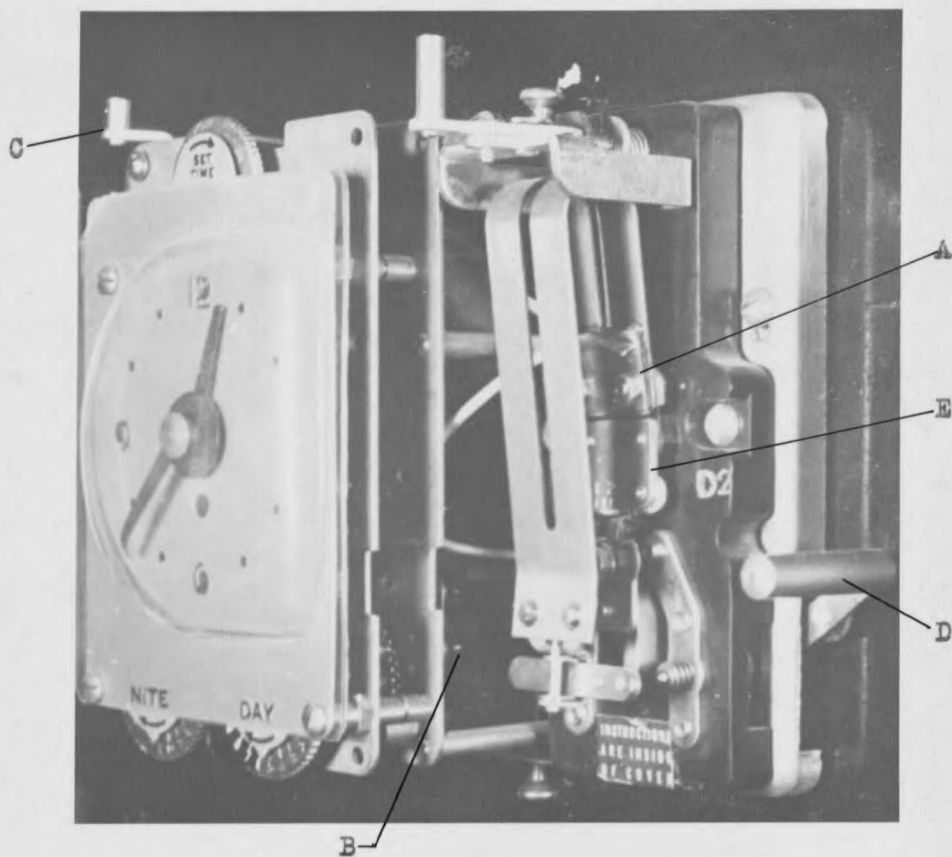

FIG. 9 SARCO THERM THERMORAY THERMOSTAT



Perfex Day-Night Thermostat

Figure 10

adjusted for 0°, 5° or 10°F set-back. The switch (B) will be opened at the setting on the day dial and the thermostat will return to normal operation. Another feature of the particular control illustrated is the frequency indicator (D). This varies the amount of resistance in the heat anticipator resistance (E) and adjusts the length of cycle that the contacts will be closed.

Another type of night set-back thermostat consists of two separate bimetal thermostats and a clock-operated switch. The day temperature is set on one thermostat and the night temperature on the other and the clock-operated switch shifts the circuit from one to the other according to its dial settings. The advantages of this over a single thermostat with a heating element are positive action, the night thermostat may be set for any temperature and heat from the clock motor will not affect the thermostats since they are separate from the clock switch.

The advantages claimed for a night set-back device are fuel savings because of the lowered night temperature and more comfortable conditions at night.

#### Relays

A relay is necessary in controlling circulators and other 110-volt heating system components when a low-voltage thermostat is used.

#### Two-Wire Relay

A diagram of this device is shown in Figure 11. Line voltage is reduced by the transformer (B) to the low voltage, usually 24 volts,

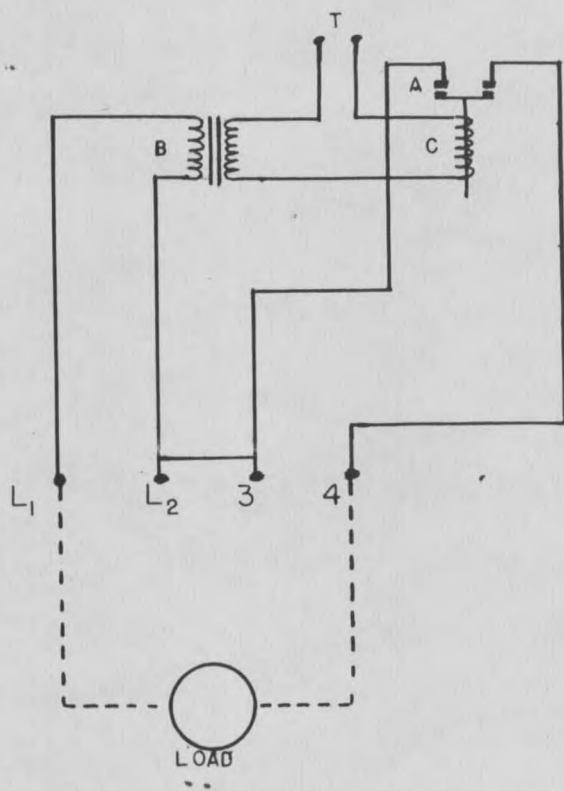

FIG. II 2 WIRE RELAY

for the thermostat circuit. The thermostat contacts are connected across (T) which is in series with the relay coil (C). When the room thermostat is calling for heat the contacts (A) are closed by the relay. The load is then connected directly across the 110-volt line, (L<sub>1</sub>) and (L<sub>2</sub>).

### 110-Volt Relay

110-volt thermostats require a relay when the load exceeds the thermostat rating. In the average residence this is unlikely, however, in cases where large circulating pumps are employed, a relay is very often used. A diagram of this relay is shown in Figure 12. Since the thermostat is rated at 110 volts, a transformer is not needed in this circuit. The relay coil (A) is in series with the thermostat contacts (T). When these contacts are closed the relay closes the heavier contacts (B) which carry the full-load current.

### Three-Wire Relay

The three-wire low-voltage thermostat requires a three-wire relay to control the circulating pump and burner, Figure 13.

This relay has two sets of contacts: heavy contacts (A) to control the load and auxiliary contacts (C). As described under thermostats, a three-wire thermostat has contacts between (R) and (W), and (B) and (W). From Figure 13 it can be seen that both sets of contacts must be closed to energize the relay. However, when contacts (W) and (B) are open to energize the thermostat heater, the relay will remain closed because of the auxiliary contacts (C). Then when (R) and (W) open the relay will open both contacts (A) and (C).

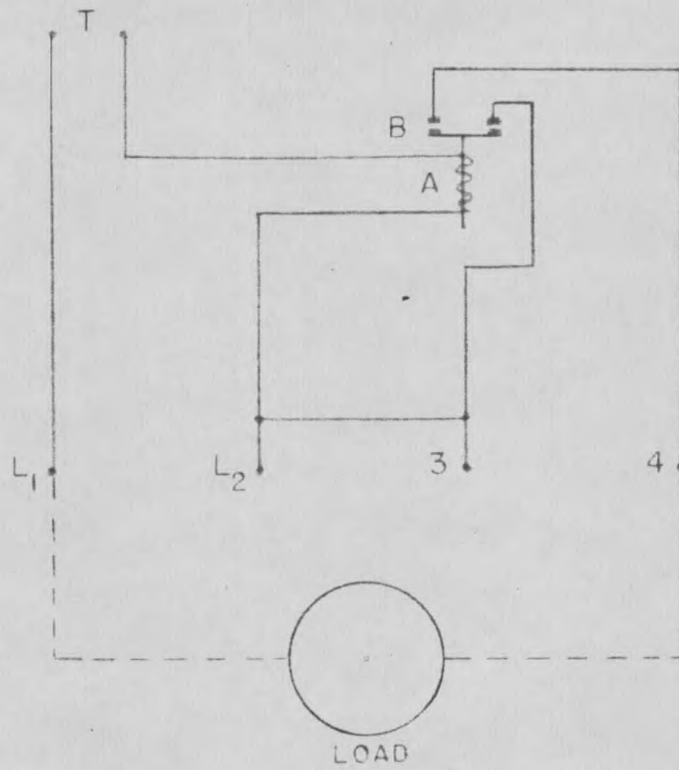

FIG. 12 LINE VOLTAGE RELAY

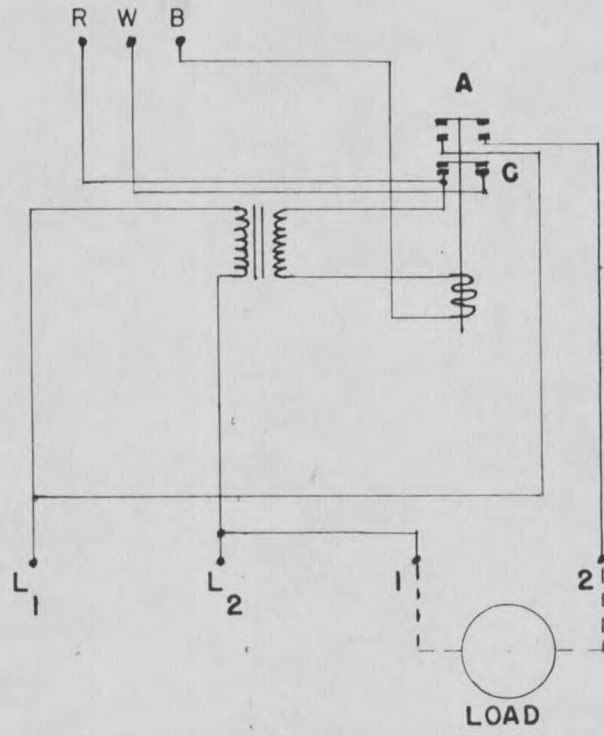

FIG.13 THREE WIRE RELAY

## Immersion Thermostats

### Bimetal Type

An immersion thermostat (Figure 14) is used for controlling the water temperature of a hot-water boiler. It consists of a helical bi-metal that is protected by a well and immersed in the water passage of the boiler. When the water reaches the set temperature the helical bi-metal trips a mercury switch and breaks contact or opens the contacts of a mechanical switch. The temperature adjustment is made by setting the distance through which the helix has to rotate to trip the switch; the greater this distance, the higher the water temperature. This control is constructed in either line-voltage or low-voltage. The usual differential is 15°F; a closer differential results in too short a burner operation for most boilers.

### Hydraulic Type

Immersion thermostats are also built to operate hydraulically with a limited charge bulb operating on a bellows or on a bourdon tube, Figure 15. When the boiler water temperature increases, the pressure in the bourdon tube increases. This tends to straighten the tube which in turn trips a mercury switch or opens the contacts of a mechanical switch.

### Gas Valves

Automatic gas valves are required to turn the gas on and off to the burner as required by the demand of the heating system.

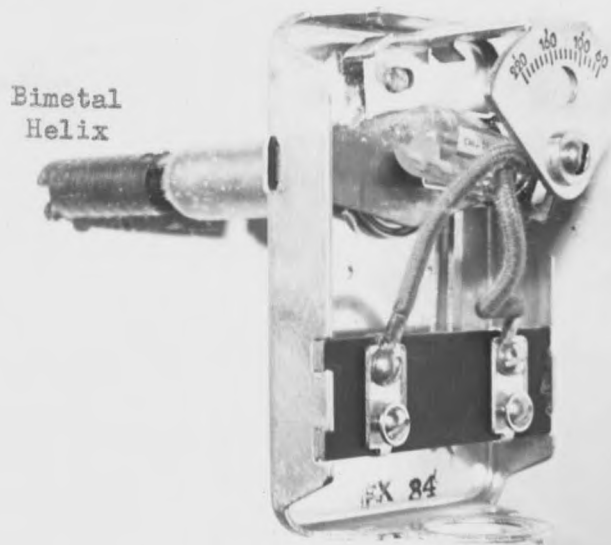

Bimetal Type Immersion Thermostat  
Figure 14

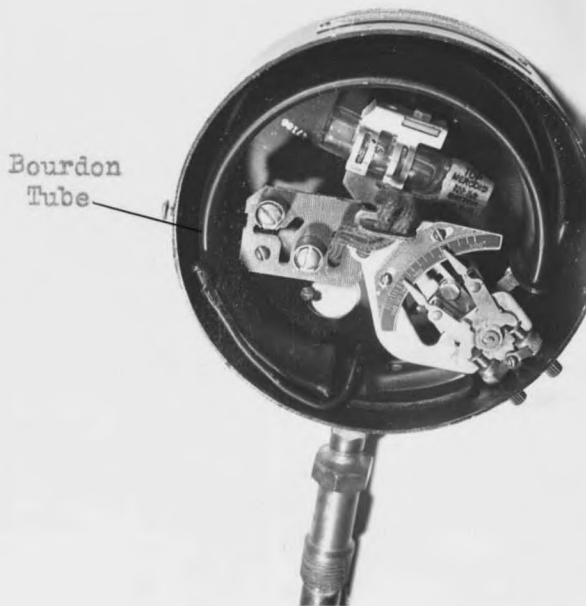

Bourdon Tube Immersion Thermostat  
Figure 15

### Solenoid Operated

The most common type of gas valve is the solenoid-operated, shown diagrammatically in Figure 16. When the solenoid is energized, the valve disc is lifted from its seat. The valve closes by gravity.

### Diaphragm Operated

Another type of gas valve is the diaphragm-operated, as shown in Figure 17. When heat is required, the solenoid-operated or magnetically-operated three-way valve bleeds gas to the diaphragm and the pressure opens the main valve. When the solenoid circuit is opened, the three-way valve bleeds gas from the diaphragm chamber into the furnace and the main valve closes.

### Hydraulically Operated

Another type of gas valve is hydraulically-operated. A heater element heats a liquid vapor filled bulb which causes the bellows or diaphragm to expand and open the valve. When the circuit to the heater is opened, the bulb cools and the valve closes.

### Heat Motor Operated

The heat-motor-operated gas valve is shown in Figure 18. The bimetal strip (A) is heated by a heating element. This causes the bimetal to curl upward and open the valve. A magnet and armature impart a snap action to the valve. When the valve is partially open, it pushes against an additional spring force. This delays the full opening of the valve and prevents flash or sudden explosive ignition and shut-off of the

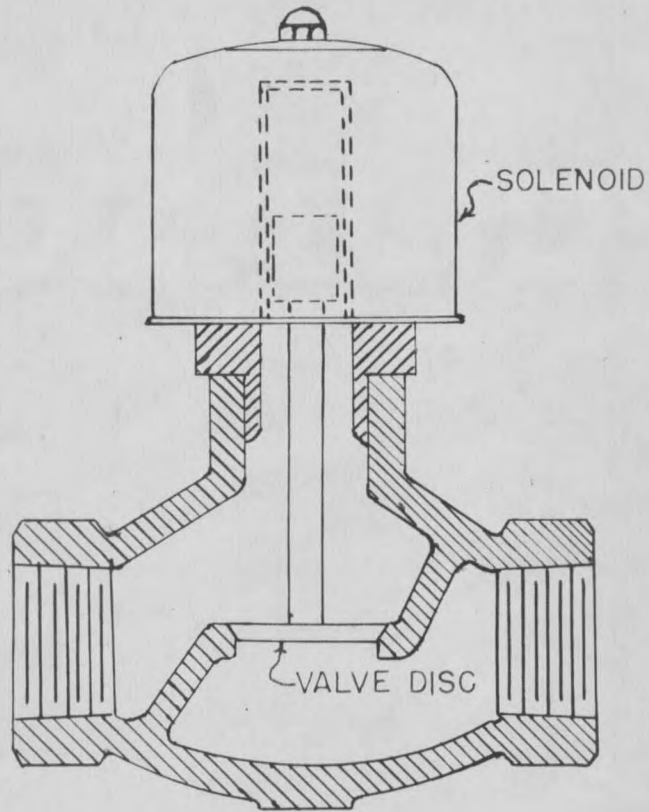

FIG.16 SOLENOID-OPERATED GAS VALVE

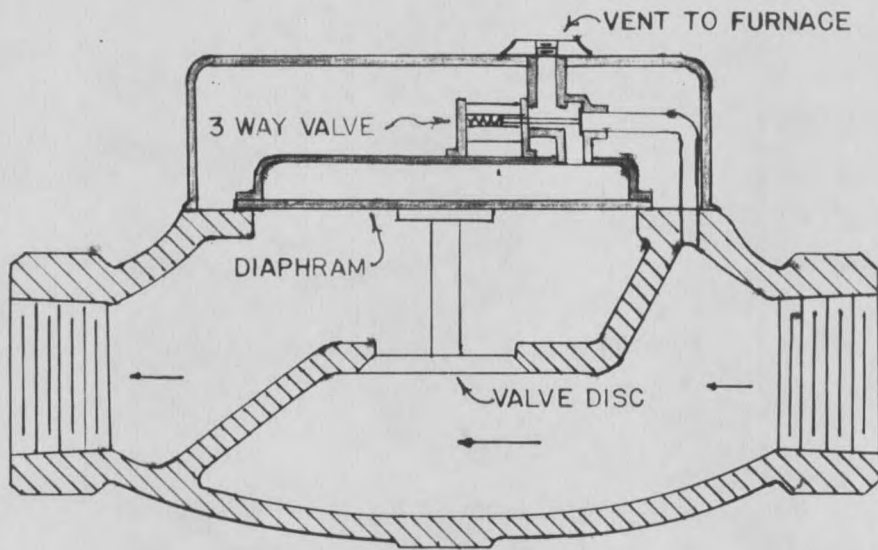
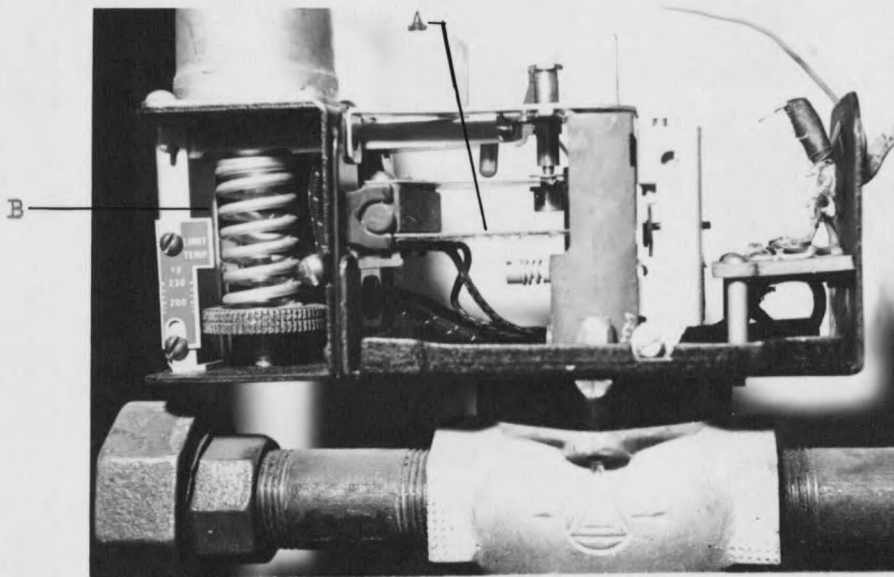

FIG.17 DIAPHRAM-OPERATED GAS VALVE



Heat-Motor-Operated Gas Valve

Figure 18

burner. Another desirable feature of this gas valve is the hydraulically-operated limit (B). When the water temperature of the boiler becomes too high the bellows operating against an adjusting spring moves a lever arm that mechanically closes the valve.

Any of the gas valves described can be obtained with a mechanical hold-open device to operate the burner in case of power failure. However, unless they have a mechanical limit feature, the boiler must be shut down manually. This necessitates constant watch of the unit during power failure. When electrical power is resumed, the controls will again return to automatic operation.

### Safety Controls

#### Safety Pilot

In gas burner control it is necessary to prevent the gas valve from opening if the pilot light should go out. Otherwise, the boiler furnace would fill with gas and an explosion hazard would exist.

To accomplish this a switch that will open if the pilot flame should go out is used. A sketch of this device is shown in Figure 19. The thermocouple in the pilot flame provides enough voltage to hold the armature against the magnet as shown. If the pilot goes out, the thermocouple will cool and the armature will be released from the magnet. The switch will then be opened by the lever system shown and the circuit to the gas valve broken. Before the system can be put back into operation the safety pilot switch must be manually reset. A similar control usually mounted at the pilot will reset automatically. However, a manual

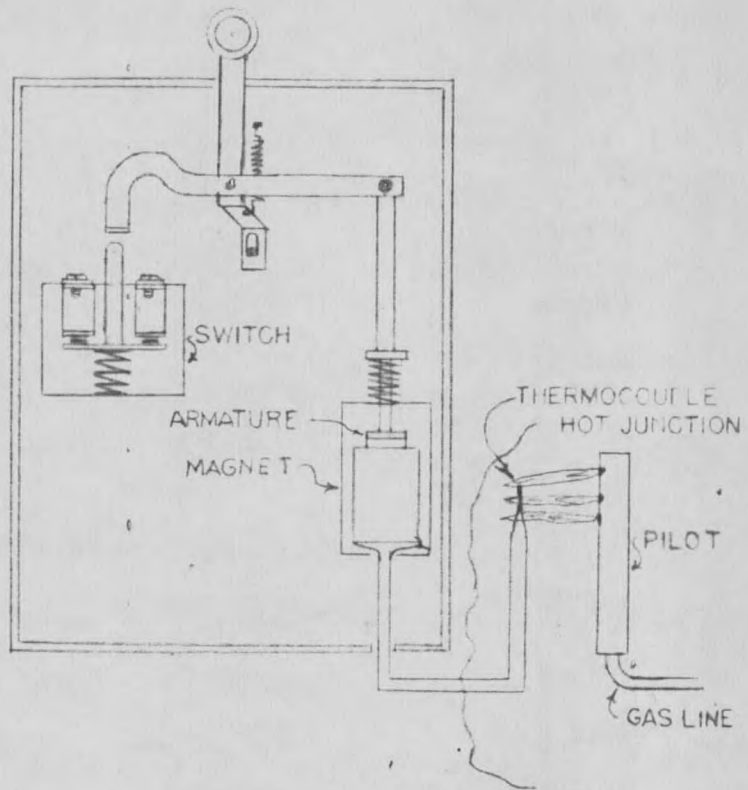

FIG. 19 SAFETY PILOT SWITCH

reset has the advantage that if something is out of order it will be detected and corrected before operation is resumed.

Another type of safety pilot consists of a solenoid gas valve that is held open with a thermocouple in the pilot flame. The advantage of this is that the safety pilot valve is separate from the operating valve. Since it is not an operating control, its life is longer and there is less chance of its failing.

### Stack Switch

In controlling the operation of an oil burner a safety switch in the stack is necessary. This switch prevents burner operation if the flue gas temperature is not at the desired level. The reason for this is that if the burner should fail to ignite and the furnace is warm, the furnace would become full of oil vapor; then if the burner operated a second time and ignited, an explosion would result which would damage the boiler.

This control is illustrated in Figure 20. In the starting position switch (A) is closed. This allows current to flow through a heating element in the bimetal-operated switch (B). Switch (B) is connected in series with the main relay (C). There is a time lag required for the heater to open switch (B). If the flue temperature reaches a normal value before this time lapses, a helix bimetal in the flue will open switch (A) and the burner will remain in operation until the room thermostat or immersion thermostat opens the relay (C). In case of burner failure, the helix will not open switch (A) and the bimetal switch

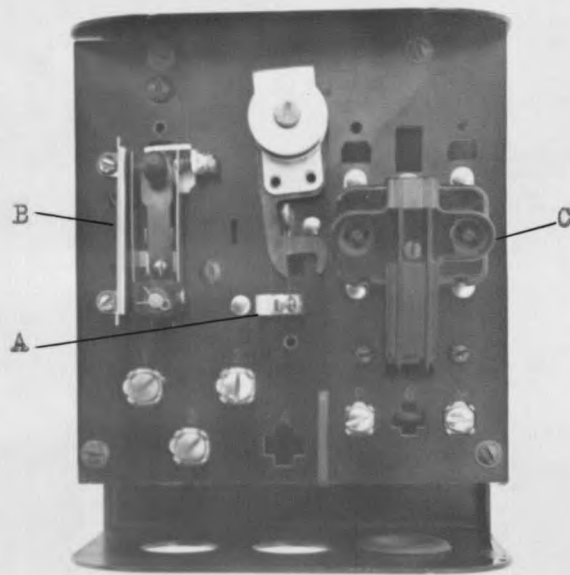

Stack Switch  
Figure 20

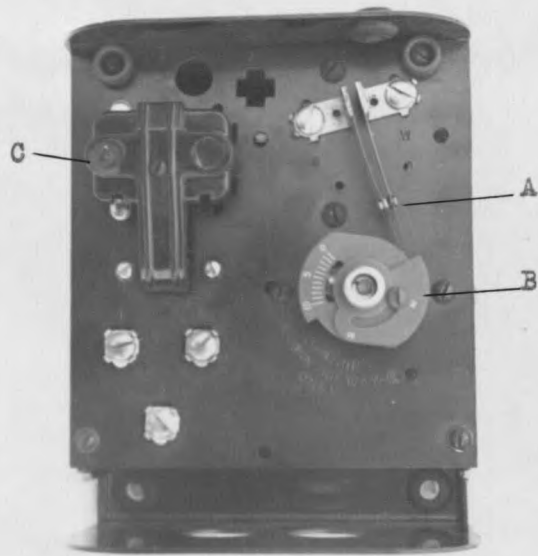

Stoker Timer  
Figure 21

will open the relay circuit and the burner will shut down until it is manually reset. A cooling period of five minutes is necessary before the switch may be reset.

### Stoker Timer

When a boiler is stoker-fired a stoker control is necessary (Figure 21). A stoker has to operate at intervals even though heat is not required, otherwise the fire would go out.

This is accomplished by an auxiliary switch (A) that is controlled by a cam (B) driven from a clock motor. This switch is in parallel with the room thermostat so that it closes the main stoker motor relay (C) whenever the contacts are closed. The cam may be adjusted to operate the stoker from 1 to 15 minutes duration every 30 to 60 minutes.

The period of operation is adjusted to meet the burning characteristics of the fuel.

### Water Valves

#### Motor-Operated Valve

This valve is operated by a reversible electric motor that is controlled by an outdoor-indoor controller or a room thermostat. It may have a limit switch to start the circulator when the valve is fully opened or the circulator may be operated separately. The valve must be fully opened or closed before it will reverse so it will not modulate. It is widely used where a zoned-control system is wanted.

### Solenoid-Operated Valve

This valve has the same applications as the motor-operated valve. The valve is opened and closed by a solenoid instead of a reversible motor and it does not incorporate a switch to operate the circulator pump.

### Heat-Motor Valve

The heat-motor valve is operated by either an electrically heated liquid-filled bellows or an electrically heated bimetal. When current is supplied to the heating element the valve will slowly open. The heating to open and cooling to close requires about four minutes. Because of this slow operating time, the valve will tend to modulate to meet the demand. If it is controlled by a heat anticipating room thermostat, it will assume a partially open position. Its applications are the same as the other water valves.

### Controls Used With Tankless or Direct Domestic Water Heaters

A tankless domestic water heater consists of a coil of tube submerged in the boiler water. Domestic water flows through this coil where it is continuously heated. This eliminates the need for a storage tank.

It is not economical to size a boiler to handle both the heating load and the domestic water load at the same time; therefore, the circulation to the heating panel is stopped during the short periods when domestic water is drawn.

With a tankless domestic water heater the boiler water must be maintained at a temperature of at least 175°F. Since this water is much too hot for panel heating it must be blended with return water to supply the heating circuits.

#### Reverse-Acting Immersion Thermostat

Immersion thermostats are made with contacts that open on a temperature drop. With this control wired in series with the circulating pump it will shut off the circulator to provide full boiler capacity for domestic hot water when the boiler water temperature drops below the control setting, usually 180°F. The reverse-acting immersion thermostat has the advantage that it may be set to turn off the circulator at any value in a wide range.

#### Thermostatic Flow-Check Valve

This valve will stop the circulation to the heating panel to provide full capacity for domestic hot water when the boiler water temperature drops below 177°F.

A thermostatic element (Figure 22) opens the valve at 182°F and closes it at 177°F. There is a hole in the valve disc to allow a small flow at all times so the thermostat will sense the temperature with the valve closed.

#### Thermostatic Three-Way Valve

This valve is used to blend return water with the boiler water

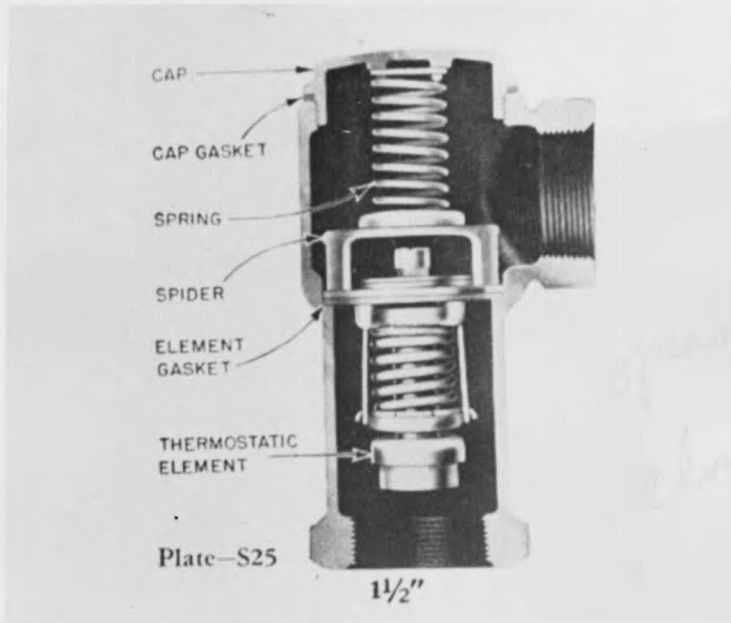

Thermostatic Flow-Check Valve  
Figure 22

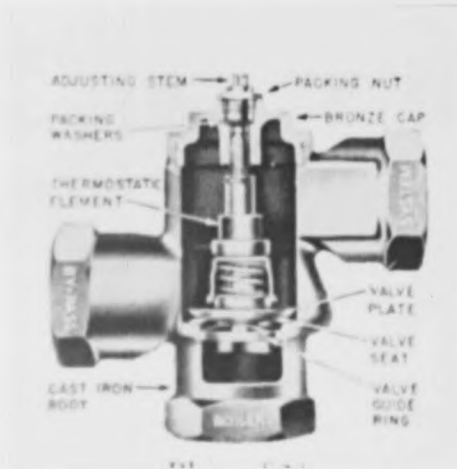

Thermostatic Three-Way Valve  
Figure 23

to give constant panel supply water at any temperature between  $110^{\circ}\text{F}$  and  $150^{\circ}\text{F}$  when the boiler water temperature is above these values. From Figure 23 it may be seen that the valve is controlled by a limited-charge thermostatic element. When the water temperature is too hot the bellows expand and close the boiler supply. If the blended water becomes too cool, the bellows pressure is reduced and the valve opens. Under steady return water conditions this valve will assume a partially open position to maintain a constant blended temperature with very little hunting.

Chapter II  
CONTROL CIRCUITS

Introduction

Chapter II explains the entire control system. Wiring diagrams are given for the systems discussed and piping diagrams are shown where necessary.

Previously control systems have been classified as to their motivating force. These classifications are:

1. Electric
2. Hydraulic
3. Mechanical
4. Electronic
5. Pneumatic

Since most systems used for forced hot water heated floor slabs involve a combination of these classifications, it seems more practical to classify control systems according to their function. This would leave two main classifications and various sub-classifications as follows:

- I. Indoor controls:
  - (a) Intermittent circulation
  - (b) Continuous circulation
  - (c) Tankless domestic hot water from the boiler
- II. Indoor-outdoor controls:
  - (a) Modulating mixing valves
  - (b) Boiler burner control

(c) Control of the length and frequency of cycle  
of the heating system

Pneumatic controls have not been considered since they employ compressed air and are not deemed practical for residences except for large installations where multiple zones are used.

## INDOOR CONTROL SYSTEMS

### Intermittent Circulation

#### Low-Voltage

There are several circuits that may be used for this system. The two most common are shown in Figure 24 and Figure 25.

In the case of the circuit shown in Figure 24 the thermostat closes the relay contacts. This starts the circulator and the burner. When the boiler water is up to the desired temperature the immersion thermostat will open the burner circuit and the burner will shut off even though the circulator is still running. The safety control (safety pilot for gas burners or stack switches for oil burners) will open the burner circuit in case of pilot failure on gas-fired boilers or ignition failure on oil-fired boilers. In this system the burner cannot operate without the thermostat calling for heat. This feature is advantageous in that the burner will not cycle just to supply radiation and stack losses from the boiler.

The circuit shown in Figure 25 differs from that in Figure 24 in that the transformer primary is directly across the line. With this arrangement, the immersion thermostat controls the burner operation whether the thermostat is calling for heat or not. The room temperature is maintained by the thermostat controlling the circulating pump. This system is used with large boilers or where tankless hot water is desired. With tankless domestic hot water, an immersion thermostat that opens contacts on a temperature drop may be used.

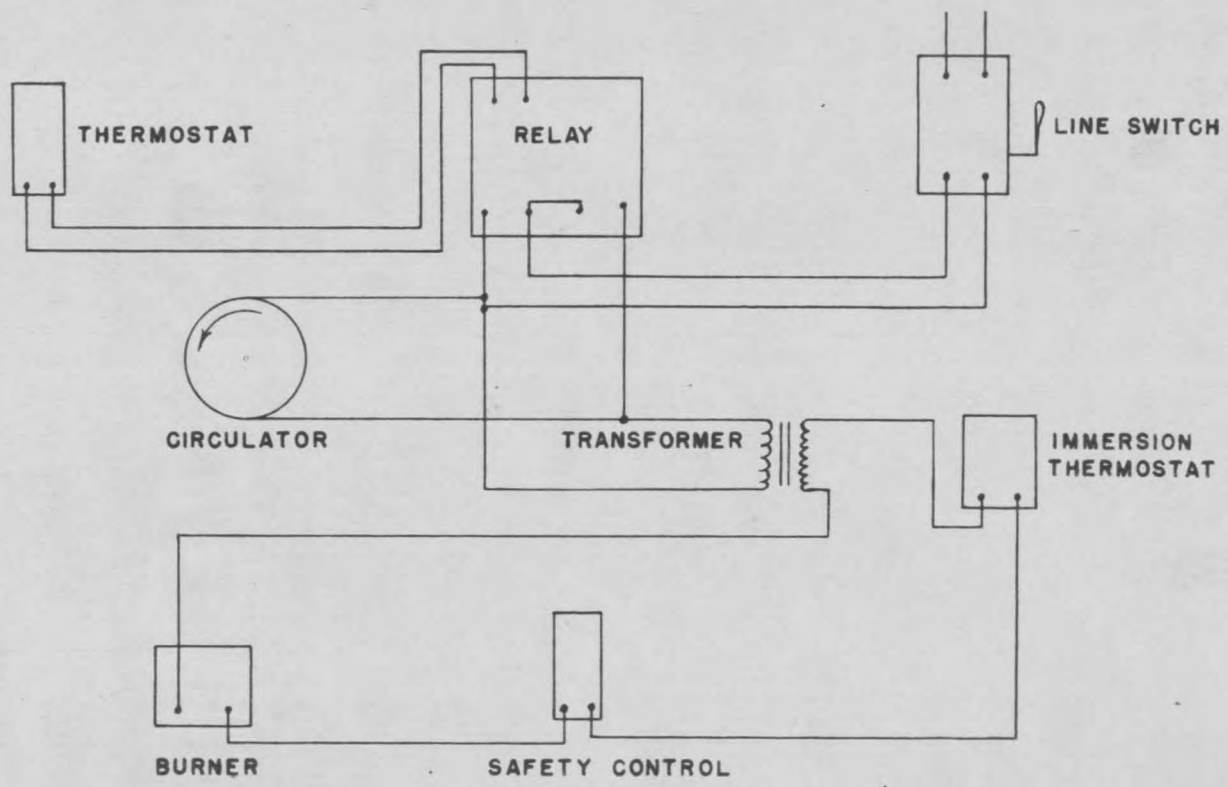

LOW VOLTAGE CONTROL CIRCUIT INTERMITTENT CIRCULATION

FIG. 24

NOTE: IMMERSION THERMOSTAT WITH CONTACTS THAT OPEN ON TEMPERATURE DROP USED WITH DIRECT DOMESTIC WATER HEATER IF THERMOSTATIC FLOW CHECK VALVE IS NOT USED

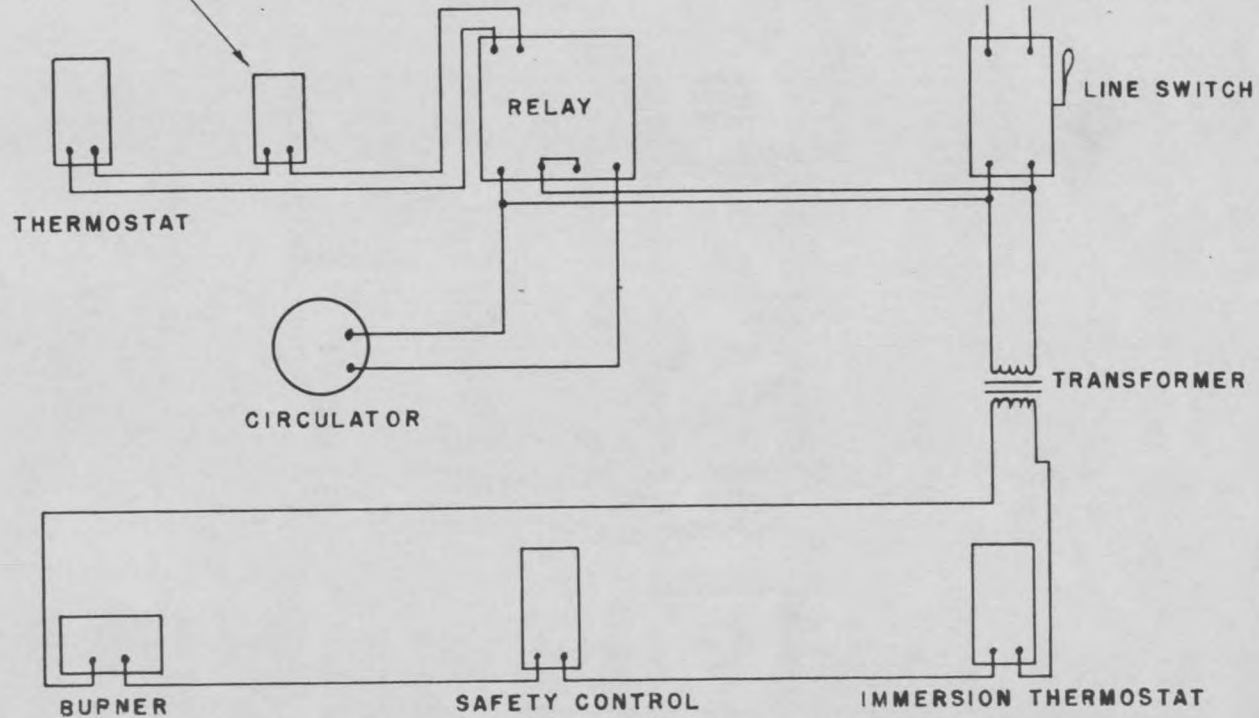

LOW VOLTAGE INTERMITTENT CIRCULATION  
IMMERSION THERMOSTAT CONTROLS BOILER TEMPERATURE

FIG. 25

### 110-Volt (Line Voltage)

This circuit is shown in Figure 26. The 110-volt thermostat carries the full load current. When the room has reached the temperature setting of the thermostat the circuit is open to the circulator and burner controls. As in the low voltage system the circuit may be arranged to keep the boiler up to temperature at all times. This system is shown in Figure 27.

### Continuous Circulation

#### Low-Voltage

In this system the circulator runs continuously and the thermostat controls the burner. From Figure 28 it can be seen that the thermostat closes the relay contacts which connect the burner circuit across the line. The immersion thermostat will limit the boiler water temperature by opening the burner circuit. This system cannot be used with tankless domestic hot water from the boiler since a tankless water heater requires that the boiler be up to 175°F at all times.

#### 110-Volt

This circuit is shown in Figure 29. The 110-volt thermostat controls the burner circuit. Since the immersion thermostat is in series with the thermostat it acts as a high temperature limit. The circulator is directly across the line so it will run continuously. As in the continuous circulation low-voltage circuit, this cannot be used when a tankless domestic hot water heater is desired.

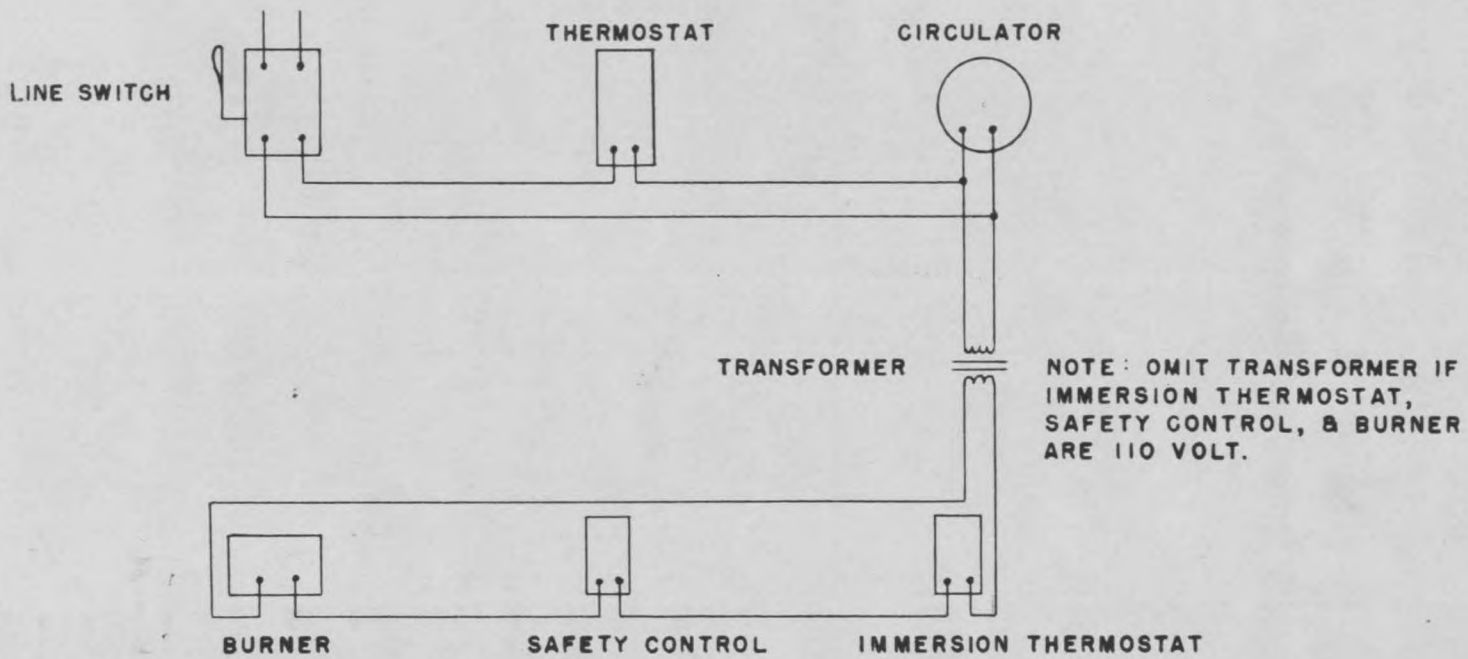

110 VOLT INTERMITTENT CIRCULATION

FIG. 26

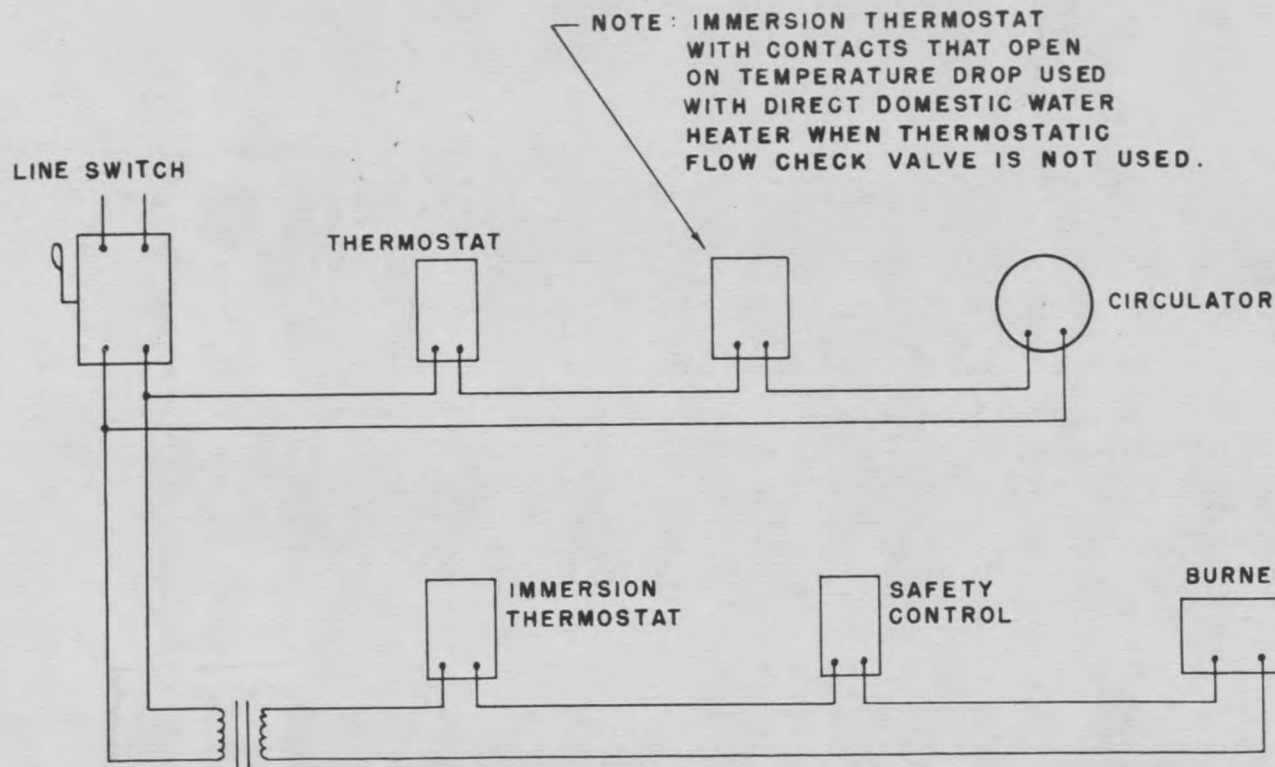

110 VOLT INTERMITTENT CIRCULATION  
IMMERSION THERMOSTAT CONTROLS BOILER TEMPERATURE

FIG. 27

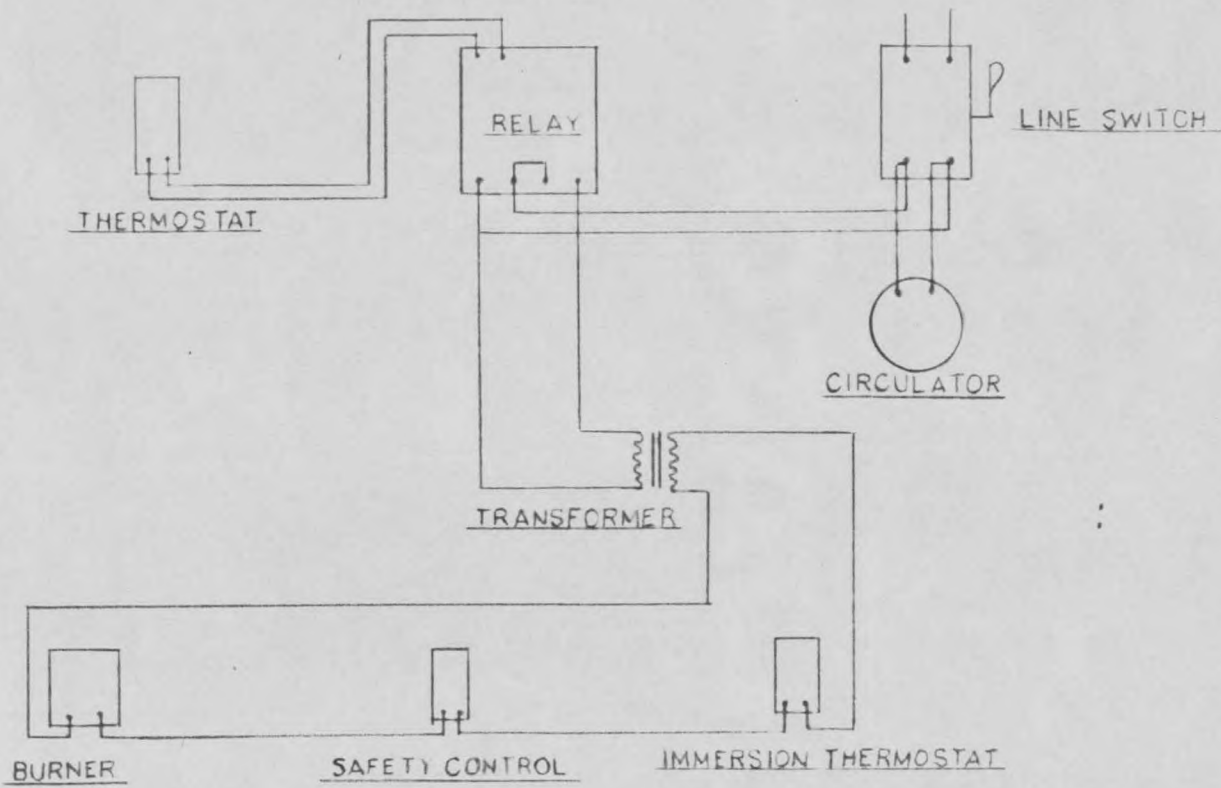
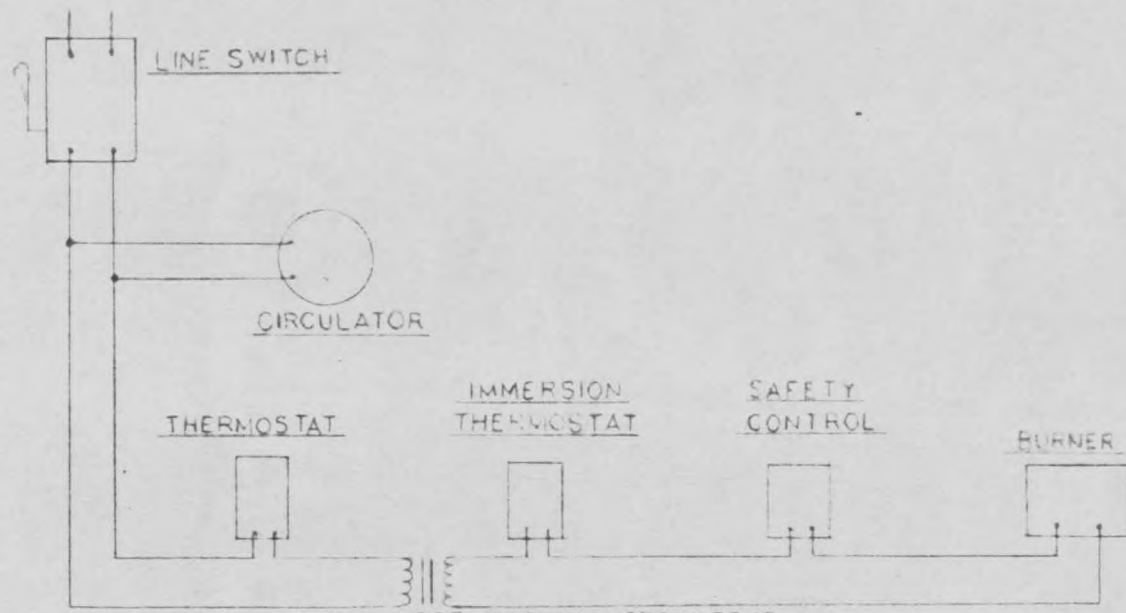

FIG. 28 LOW VOLTAGE CONTINUOUS CIRCULATION



NOTE: OMIT TRANSFORMER IF  
 IMMERSION THERMOSTAT,  
 SAFETY CONTROL & BURNER  
 ARE 110 VOLT.

FIG. 29 110 VOLT CONTINUOUS CIRCULATION

### Tankless Direct Domestic Hot-Water Circuits

When this is desired, the circuits shown in Figure 25 or Figure 27 may be used since the boiler must be maintained at a temperature of at least 175°F.

Since a floor panel requires a moderate water temperature, a by-pass must be used to mix return water with the boiler water to give the proper supply-water temperature. Either a manual valve in the by-pass or a thermostatic three-way valve may be used to control the supply water temperature. The manual valve is satisfactory although the thermostatic valve gives easier adjustment. Both of these piping arrangements are shown in Figure 30. The thermostatic flow check or reverse-acting immersion thermostat prevents the heating system from lowering the boiler water below 175°F, thus assuring constant domestic hot water.

### INDOOR-OUTDOOR CIRCUITS

#### Sarcotherm Indoor-Outdoor Modulating Mixing Valve

The Sarcotherm modulating mixing valve is shown in Figure 31. This valve is designed to modulate the panel water temperature in order to maintain a constant room temperature. It is thought that a sudden rise or drop in outdoor temperature would cause a wide fluctuation in room temperature because of the mass of a concrete slab.

The valve is actuated by the combined supply water thermostatic element (T) and valve operator bellows. The pressure exerted in these bellows is controlled by the outside bulb (D) and the auxilliary bulb (Q) as well as the supply water thermostatic element. The water from the

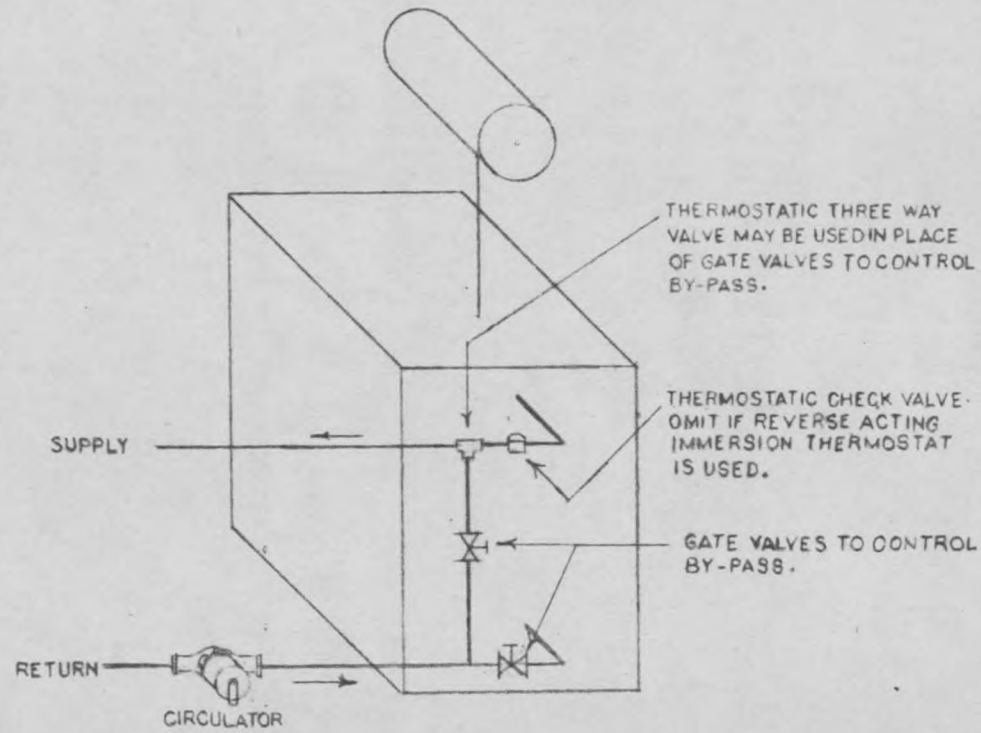
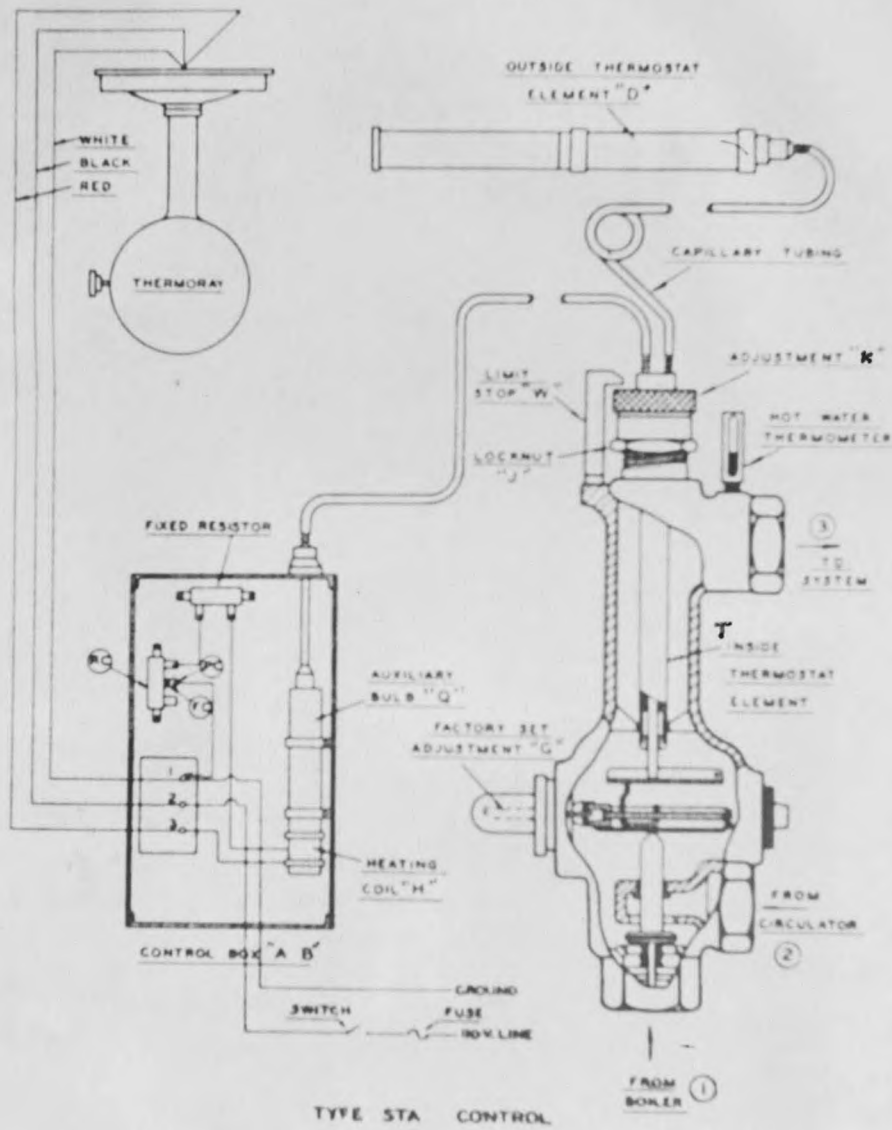

FIG. 30 BOILER CONNECTIONS WITH A TANKLESS WATER HEATER



Sarcotherm Indoor-Outdoor Modulating Mixing Valve

Figure 31

boiler enters the valve at (1) where it is mixed with return water from the circulator entering at (2). The temperature of the mixed water depends on the position of the valve disc between ports (1) and (2). The position of this valve is controlled by the blended water acting on the inside thermostat element, the outdoor-air temperature on the outside element and the heat supplied to the auxiliary bulb. The adjustment (K) adjusts the water temperature to the panel. Tightening the curled nut puts more pressure on the thermostatic element (T) and reduces the water temperature. An additional fine adjustment is given by adjusting the amount of current that will flow through the heating element (R) around the auxiliary bulb. This is accomplished by a variable resistance in series with the heater. This auxiliary bulb heater may also be used for control purposes with a room thermostat or Thermoray radiant heat thermostat. With this control it is customary to have the circulator directly across the line to give continuous circulation. A typical piping diagram for this control is shown in Figure 32.

#### White-Rogers Indoor-Outdoor Burner Control

This control, shown in Figure 33, adjusts the boiler water temperature according to outdoor temperature. It consists of a liquid-filled indoor bulb, capillary and bellows, and a liquid-filled outdoor bulb, capillary and bellows connected by an adjustable leverage system. The indoor bulb is placed in the supply water from the boiler and the outdoor bulb is exposed to outdoor air temperature.

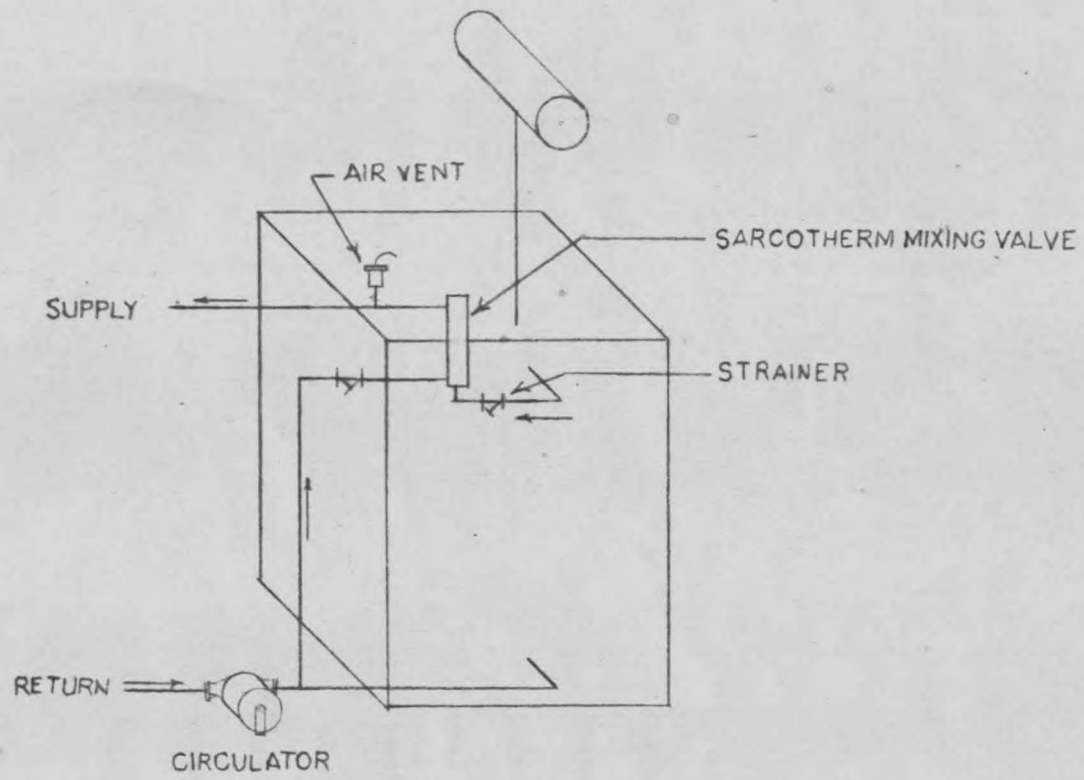

FIG.32 BOILER PIPING FOR SARCOTHERM MIXING VALVE

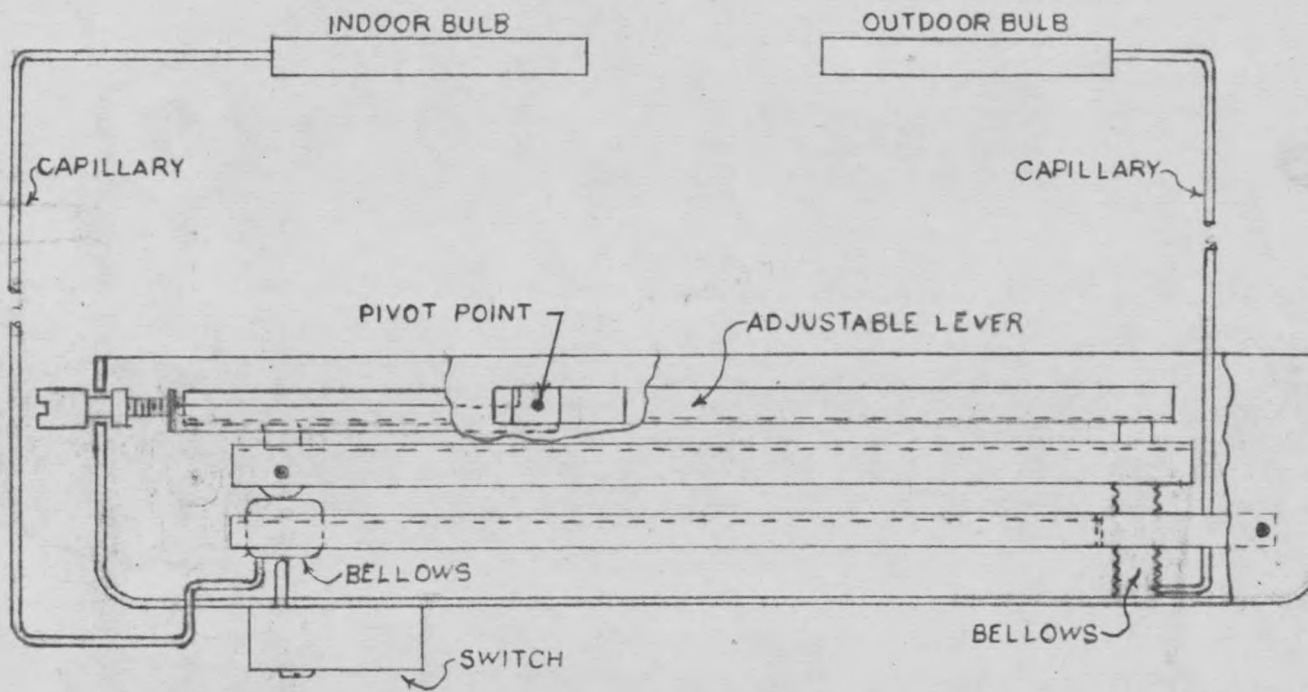

FIG. 33 WHITE ROGERS INDOOR-OUTDOOR BURNER CONTROL

When the boiler water temperature reaches the desired setting, the liquid in the indoor bulb expands enough to open the switch which is connected in series with the burner. If there is a drop in outdoor temperature, the liquid in the outdoor bulb contracts and relieves the force on the switch and starts the burner. The burner will remain on until the liquid in the indoor bulb expands enough to again open the switch. The boiler water temperature rise for an outdoor temperature drop is adjusted by moving the pivot point of the adjustable lever further from or closer to the switch. Moving the pivot point closer to the switch gives the outdoor bellows a longer lever arm so that a change in outdoor temperature will cause less movement of the lever at the switch and a smaller increase in boiler water temperature will be needed to open the switch. If the pivot point is moved further away from the switch, a higher boiler water temperature for a given outdoor temperature will result. Figure 34 shows the usual wiring diagram for this control.

The White-Rogers indoor-outdoor control operates the burner and the immersion thermostat acts as a boiler water temperature limit. The room thermostat is set above the room air temperature obtained with the indoor-outdoor control and it acts as a limit and shuts the circulator off if the room becomes too warm because of internal changes such as an increased number of people occupying the room.

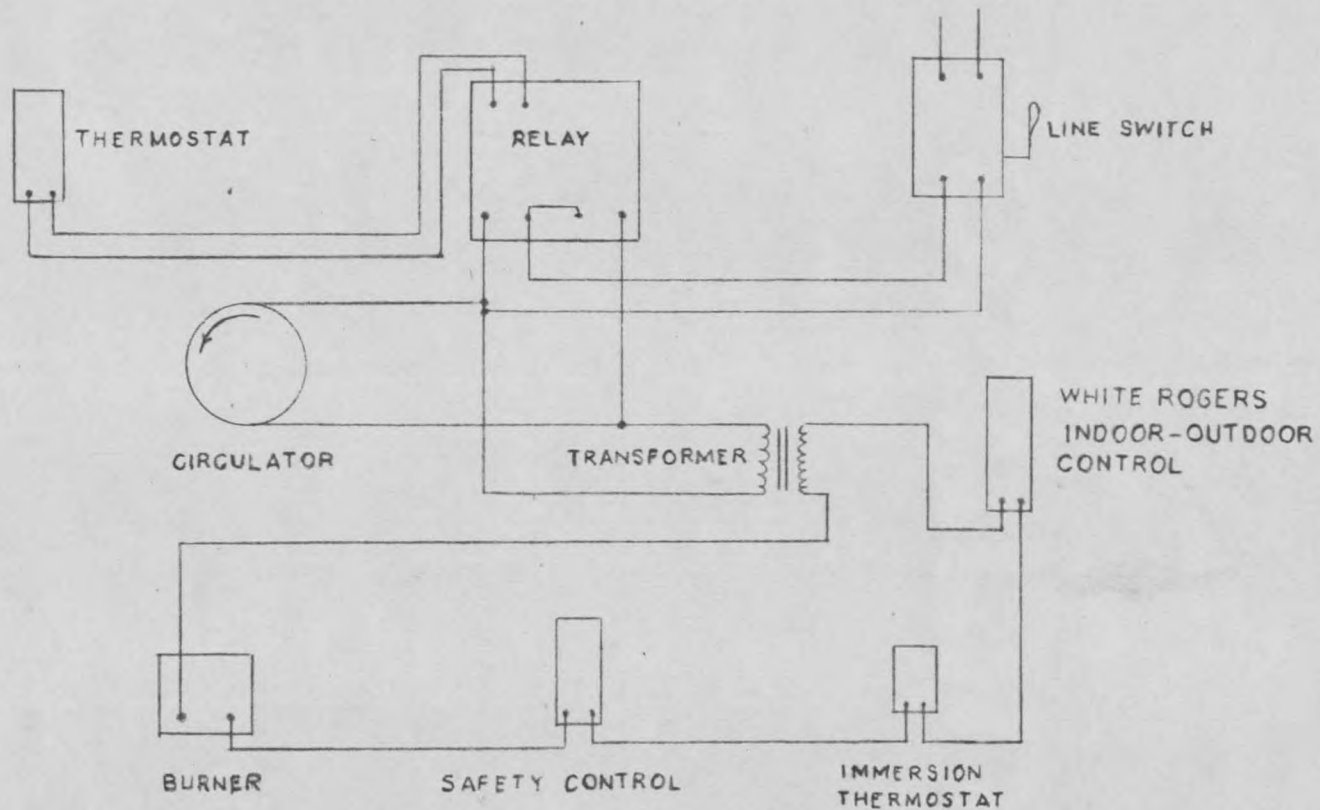

FIG. 34 WIRING DIAGRAM FOR WHITE ROGERS INDOOR-OUTDOOR CONTROL

Control of the Length and Frequency of

Cycle of the Heating System

Minneapolis-Honeywell Electronic Moduflow

The Minneapolis-Honeywell Electronic Moduflow control system (Figure 35) uses electrical resistances as temperature sensing elements. It has a resistance room thermostat, immersion thermostat, outdoor thermostat and cycler. Changes in these elements are detected by an amplifier and relay that turns the heat source on and off. This amplifier and relay is constructed in one unit and it is called a relay amplifier.

A drop in outdoor temperature causes a lowering of resistance in the outdoor thermostat which causes the heat source to start unless the room temperature is above the control point. The operation of the heat source causes a rise in temperature of the return water to the panel which raises the resistance of the immersion thermostat until it balances with the drop in resistance of the outdoor thermostat. The room thermostat modifies the action of the outdoor anticipator and immersion thermostat to compensate for internal load changes. The cycler contains an electric heater as well as a resistance. When the heat source operates, the cycler heats and eventually cancels out the original resistance change, shutting off the heat source and removing the heater voltage from the cycler. The cycler then cools and the cycle is repeated. The heavier the load requirements, the hotter the cycler will have to become to balance the resistance. This increases the length of cycle and since the cycler resistance will cool faster at the higher temperature, the frequency

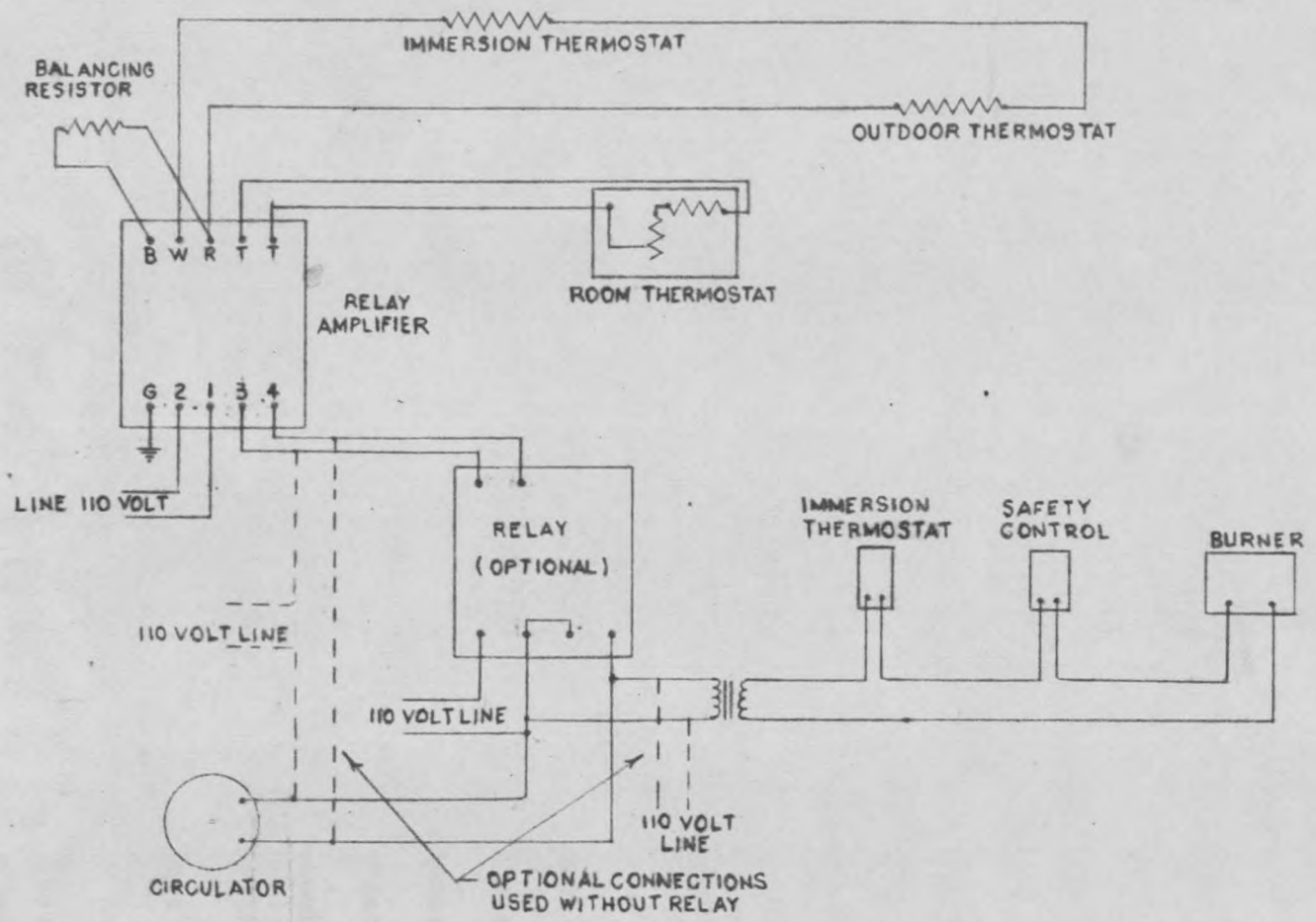

FIG. 35 MINNEAPOLIS HONEYWELL ELECTRONIC MODUFLOW

of the cycle is increased. The resistance change is detected by the relay amplifier and when the signal becomes great enough a relay closes, switching on the heat source and cycler heater.

Figure 36 is a schematic diagram of the electronic circuit. The immersion thermostat, outdoor thermostat, cycler and room thermostat are arranged in a bridge circuit as shown. With all of the thermostats at 70°F the bridge is balanced and the voltage from ground at (R) is zero. A change in resistance of any thermostat causes a voltage at (R). To illustrate this, assume that the outdoor temperature drops. This causes a decrease in resistance at the outdoor anticipator with a corresponding increase in current through the circuit (GRD). With no change in resistance from (R) to (C) the voltage drop across (RC) would be greater than the voltage drop from (R) to (D). This results in a positive voltage at (R) with respect to ground when the plate voltage of the 12SN7 tube is positive. When this condition exists the tube will pass enough current to pull in the current sensitive relay and start the heat source. There is enough inertia in the relay so that it will remain in during the negative half cycle.

If the bridge is brought out of balance by an increase of resistance due to a rise in outdoor temperature or room temperature, the relay will not pull in. To illustrate this, assume that the outdoor temperature increases. This causes an increase in resistance with a corresponding decrease in current through (GRD). The voltage drop from (R) is negative when the plate voltage of the 12SN7 tube is positive or 180° out



of phase. Under these conditions the tube will not pass enough current to pull the relay in and the heat source will not operate.

### ZONE CONTROL

Zone control consists of setting up two or more individually controlled heating circuits. This is done to account for differences in occupancy, as in a factory where comfort is to be maintained in both offices and shop; differences in exposure, as in a large dwelling where the sun may warm the south side of the dwelling while the north side will remain cool; differences in water temperature required for heat transfer from the water to the surrounding space.

For resident radiant floor panels, zone control has two applications: in large dwellings where different exposures exist and in any dwelling where thick floor coverings are used in conjunction with bare floors or thin floor coverings.<sup>1</sup> An example of this is where linoleum is used in some rooms with carpeting in others. This requires different water temperatures in order to obtain the same surface temperature of the linoleum and rugs.

Figure 37 shows a piping diagram for a two-zone control. As many zones may be added as needed. With this system the water temperature to each zone may be adjusted by adjusting the amount of return water bypassed. Figure 38 shows a low-voltage control circuit for a two-zone control. The immersion thermostat controls the boiler water temperature with this circuit. Figure 39 is a line voltage control circuit for zone

---

<sup>1</sup>Classen, Leo. 1951. RADIANT HEATING DESIGN AND TESTING.

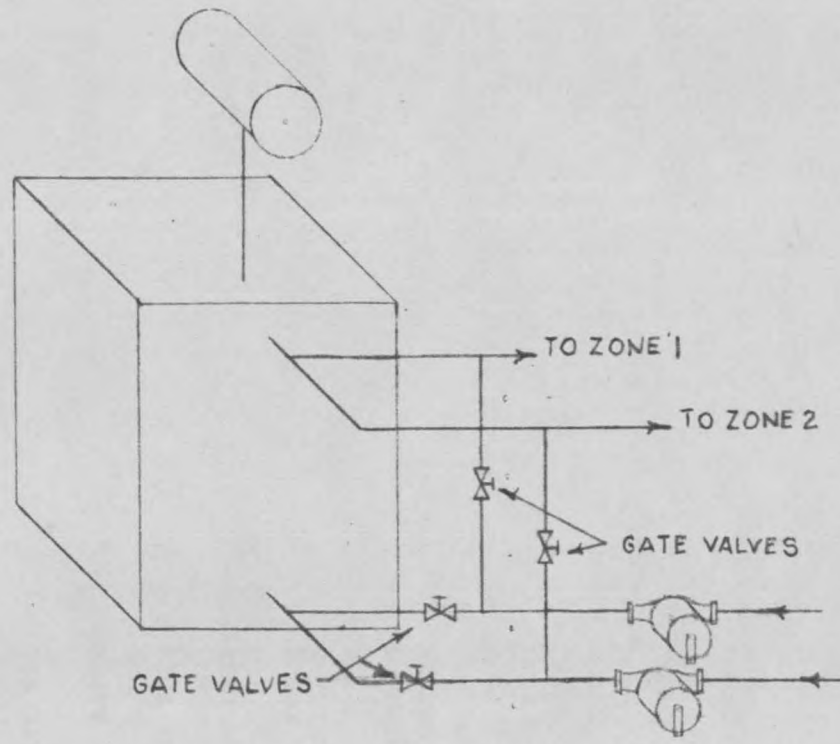
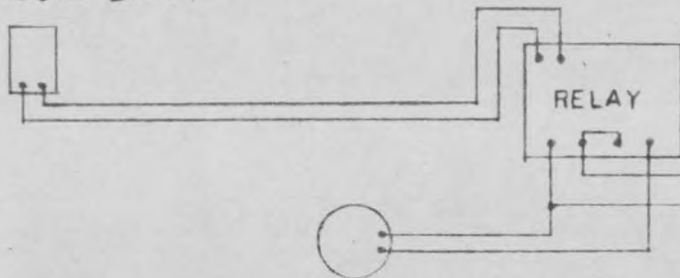

FIG. 37 BOILER PIPING FOR ZONE CONTROL

THERMOSTAT ZONE 1



RELAY

LINE SWITCH

CIRCULATOR ZONE 1

THERMOSTAT ZONE 2

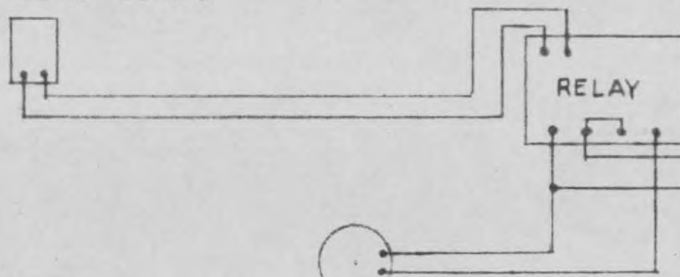

RELAY

CIRCULATOR ZONE 2



BURNER

SAFETY CONTROL

IMMERSION THERMOSTAT

FIG. 38 LOW VOLTAGE ZONE CONTROL

LINE SWITCH

THERMOSTAT ZONE 1

CIRCULATOR ZONE 1

THERMOSTAT ZONE 2

CIRCULATOR ZONE 2

IMMERSION  
THERMOSTAT

SAFETY  
CONTROL

BURNER

110 VOLT ZONE CONTROL

FIG. 39

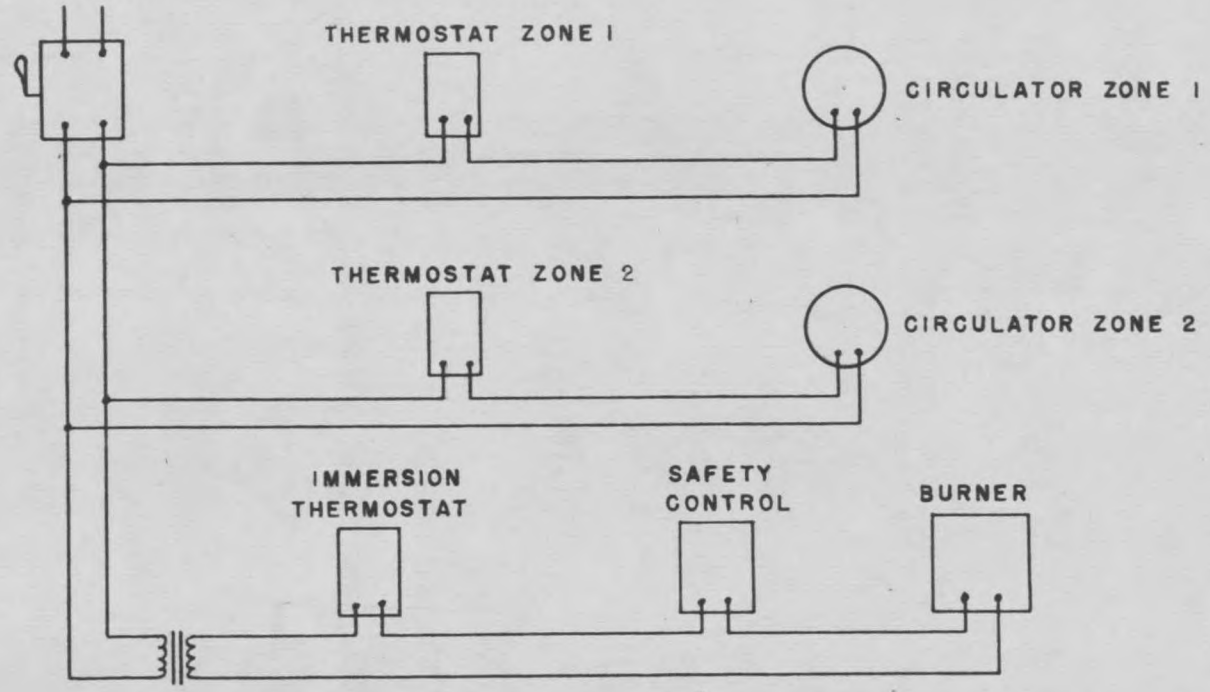

control. Either of these circuits may be used with a tankless domestic water heater.

Indoor-outdoor controls such as the Sarcotherm Modulating Mixing Valve or the Minneapolis-Honeywell Electronic Moduflow may be used as zone controls. A modulating mixing valve is installed in the piping in each zone similar to the piping arrangement shown in Figure 32 for a single zone. The outside bulb is placed in the exposure corresponding to the zone the mixing valve is controlling. If an Electronic Moduflow is used for each zone, the immersion thermostats are placed in the return lines from each zone and the relay amplifier cycles the circulator as shown with the optional connections of Figure 35.

The White-Rogers burner control may also be used as a zone control. When this is done the immersion thermostat controls the burner and the White-Rogers control for each zone operates a water valve that replaces the gate valve that is shown in the return line in Figure 37.

Chapter III

CONTROL TESTS

Introduction

The following manufacturers donated controls or other heating equipment for these tests:

American Radiator and Standard Sanitary Corporation

Fenwal, Inc.

Mercoid Corporation

Minneapolis-Honeywell Regulator Company

Penn Controls, Inc.

Perfex Corporation

Parcotherm Controls, Inc.

Sullivan Valve and Engineering Company

Taco Heaters, Inc.

Thrush Company

These controls represent a good cross-section of those manufactured at the present time.

Tests were conducted in the Radiant Heating Laboratory, the residence of David Wessel and Danforth Chapel.

### Purpose

The purpose of these tests was to determine the most satisfactory control system available for radiant heated residences with floor panels.

### Control Cost and Power Requirement Tests

#### Procedure

An average obtained from the power consumption of five circulating pumps used for residence hot water heating was found with a General Electric Type AP9 Wattmeter. The pump was arranged in a closed circuit in series with a Fischer-Porter flow meter and a gate valve to control the flow as shown in Figure 40. For comparison the power consumption at 10 gpm was used. This is equivalent to 100,000 Btu per hour which is adequate for most residences. The power consumption of relays was estimated at 5 watts. The additional power required for the indoor-outdoor controls was obtained from the manufacturer. From data of the on-and-off period of the circulating pump installed in the David Wessel residence a conservative value for the power required for intermittent circulation is half of the continuous value.

All prices were taken from manufacturers' catalog list prices. Where more than one manufacturer made the control, an average price was used. The price of thermostats varied only 40 cents and the price of relays \$1.00. There was no difference in price between thermostats with heat anticipation and those without.

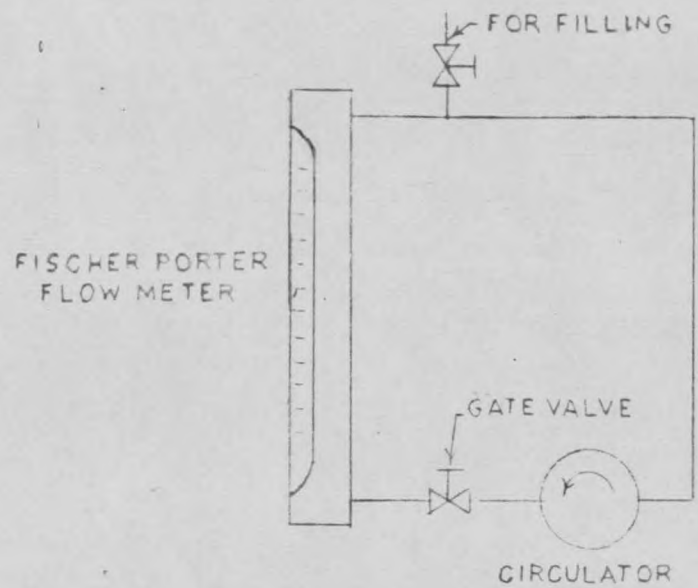

FIG. 40 CIRCULATOR TEST

Burner controls are not included in the prices since they are usually furnished with the boilers for residences.

Results of control cost and power requirement are tabulated in Table I.

Table I

Control Cost and Power Requirement

(Power requirements based on 10 gpm which requires an average of 133 watts)

Control System	Cost of Control	Estimated Installation Cost	Total Cost	Power Requirement watts
Low-Voltage Intermittent Circulation	\$22.60	\$15.00	\$37.60	71
Low-Voltage Continuous Circulation	22.60	15.00	37.60	138
110-Volt Intermittent Circulation	12.20	10.00	22.20	66
110-Volt Continuous Circulation	12.20	10.00	22.20	133
Minneapolis-Honeywell Electronic Moduflow	91.50	15.00	106.50	76
Sarcotherm with Thermo-ray Continuous Circulation	232.00	25.00	257.00	243
White-Rogers Indoor-Outdoor Continuous Circulation	80.60	15.00	105.60	138

Tests Conducted in the Radiant Heating Laboratory

Test Arrangement

The Radiant Heating Laboratory was constructed from two trailers, Figure 41. The front trailer houses the boilers, the boiler piping and the main control board, Figure 42. The rear trailer contains a radiant floor panel and the room thermostats.

The radiant floor panel that supplies heat for the rear trailer is constructed of 4 inches of concrete with 1/2-inch copper tube sinuous coils at 2 inches depth.

Since this laboratory is used for class demonstration as well as tests, it was desirable to arrange the piping and wiring so that a change from one control system to another can be effected by electrical switches and manually-operated gate valves.

Figure 43 is the piping diagram for the laboratory. With valve 1 open and valves 2, 3, 4 and 5 closed, the circulation will by-pass the mixing valves and supply water directly from the boiler for testing indoor controls, the White-Rogers indoor-outdoor burner control and the Minneapolis-Honeywell Electronic Moduflow. With valves 2 and 4 open and valves 1, 3 and 5 closed the Sarcotherm modulating mixing valve will supply blended water to the panel. With valves 3 and 5 open and valves 1, 2 and 4 closed, the Taco manual mixing valve will supply blended water to the panel.

ME Drawing No. 540 is the wiring diagram for the laboratory. Switch 1 connects the Sarcotherm to the line. Switch 2 changes from the



Radiant Heating Laboratory

Figure 41

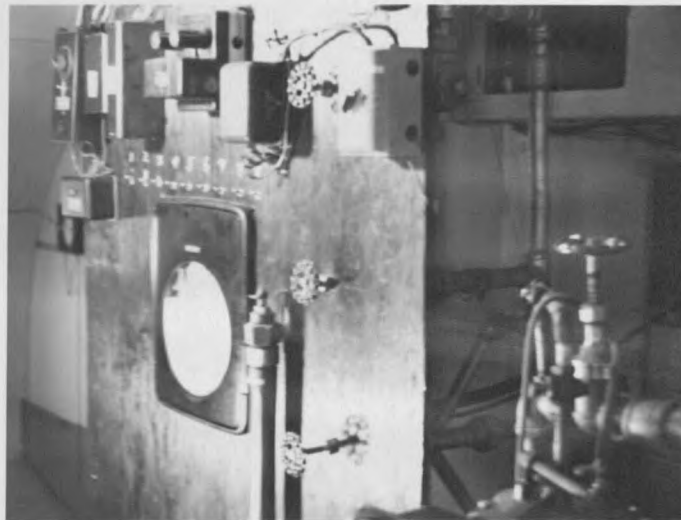

Main Control Board

Figure 42

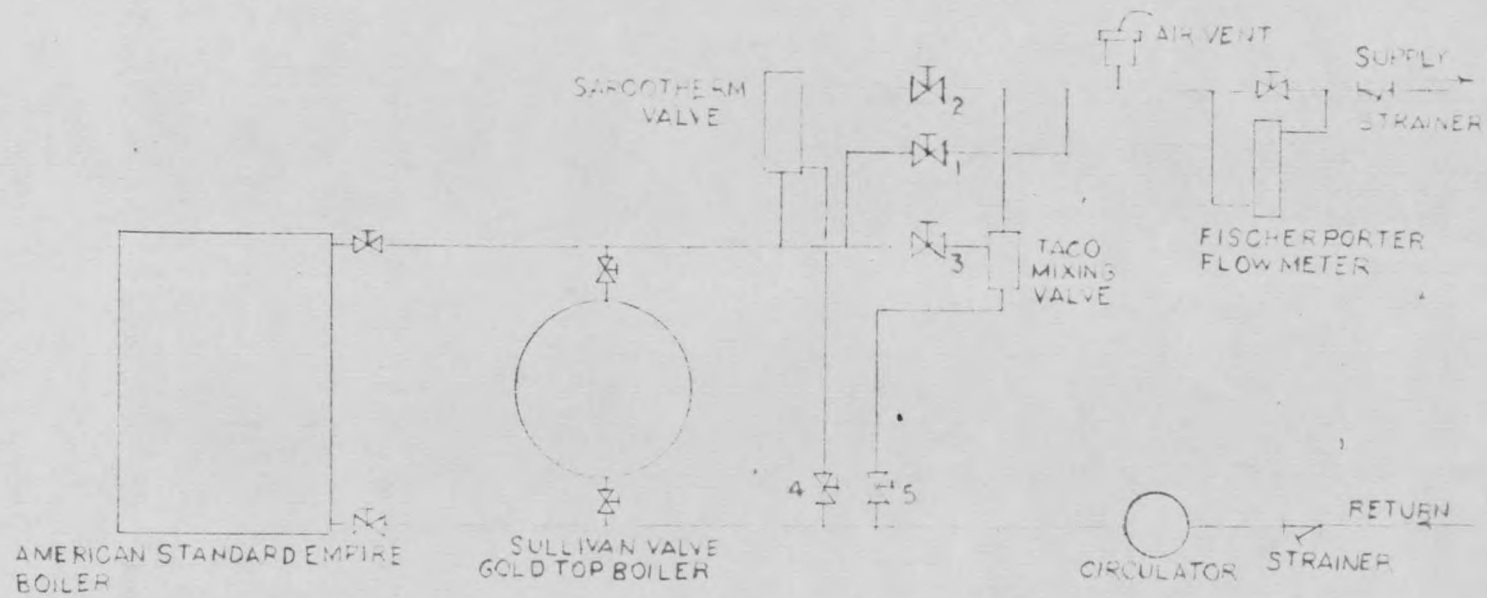
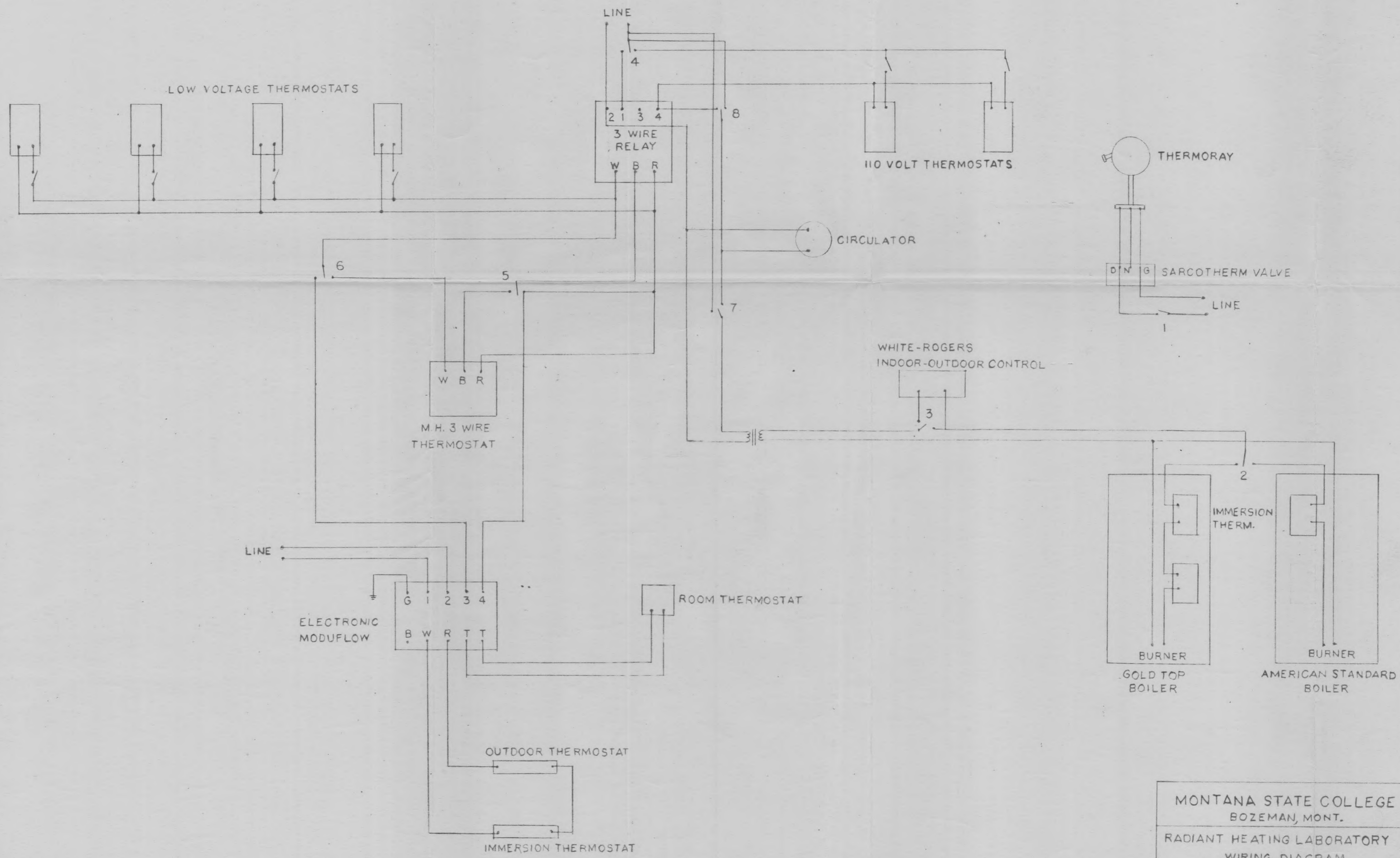

FIG. 43 RADIANT HEAT LABORATORY PIPING DIAGRAM





MONTANA STATE COLLEGE BOZEMAN, MONT.	
RADIANT HEATING LABORATORY WIRING DIAGRAM	
DRWN. J.E. HURTLE BY	NO. M.E. 340

American Standard to the Gold Top boiler. Switch 3 places the White-Rogers burner control in series with the boiler burner circuits. Switch 4 changes from low voltage to 110-volt room thermostats. Switch 5 closes the circuit between B and R on the three-wire relay so that it may be used as a two-wire relay. Switch 6 connects either the Minneapolis-Honeywell three-wire room thermostat or the Electronic Moduflow control to the relay. Switch 7 places the boiler controls directly across the line or through the relay. Switch 8 places the circulator directly across the line for continuous circulation.

With this laboratory wiring and piping arrangement, any of the control circuits shown in Figures 24 through 36 may be obtained.

#### Procedure

The room temperature in the panel test room of the Radiant Heating Laboratory was recorded with a Foxboro Dynalog resistance type temperature recorder. Record was made on 24-hour circular charts. The outdoor temperature was recorded with an Auto Lite Model 500 recording thermometer on a 24-hour chart. The temperature sensing bulb was mounted on the north end of the Radiant Heating Laboratory.

All of the controls tested were adjusted according to the manufacturers' instructions before testing.

#### Results

Typical charts of indoor and outdoor temperatures of the controls tested as shown replotted in Figures 44 to 54 inclusive.

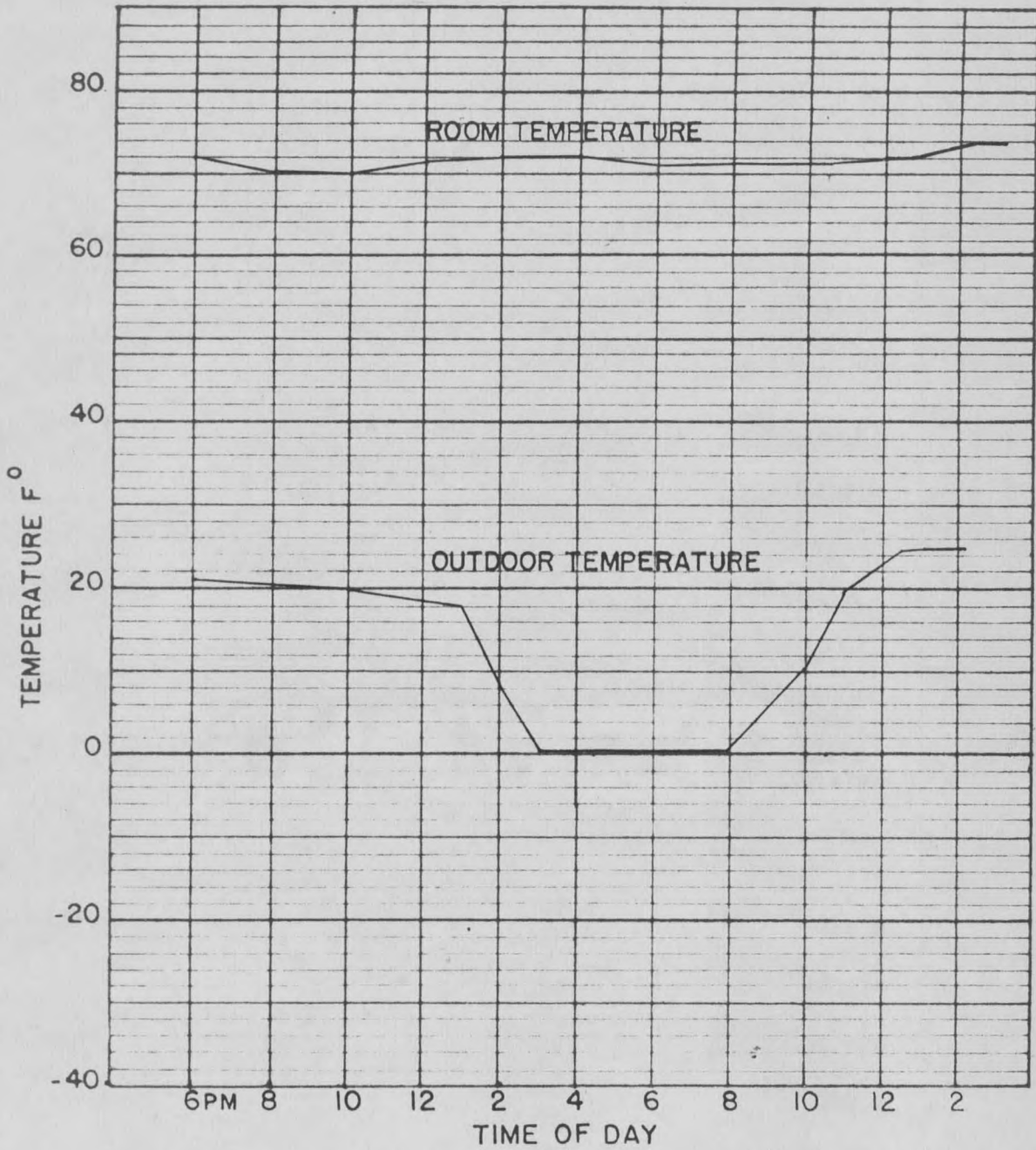

PENN LOW VOLTAGE HEAT ANTICIPATING ROOM THERMOSTAT  
INTERMITTENT CIRCULATION

FIG. 44

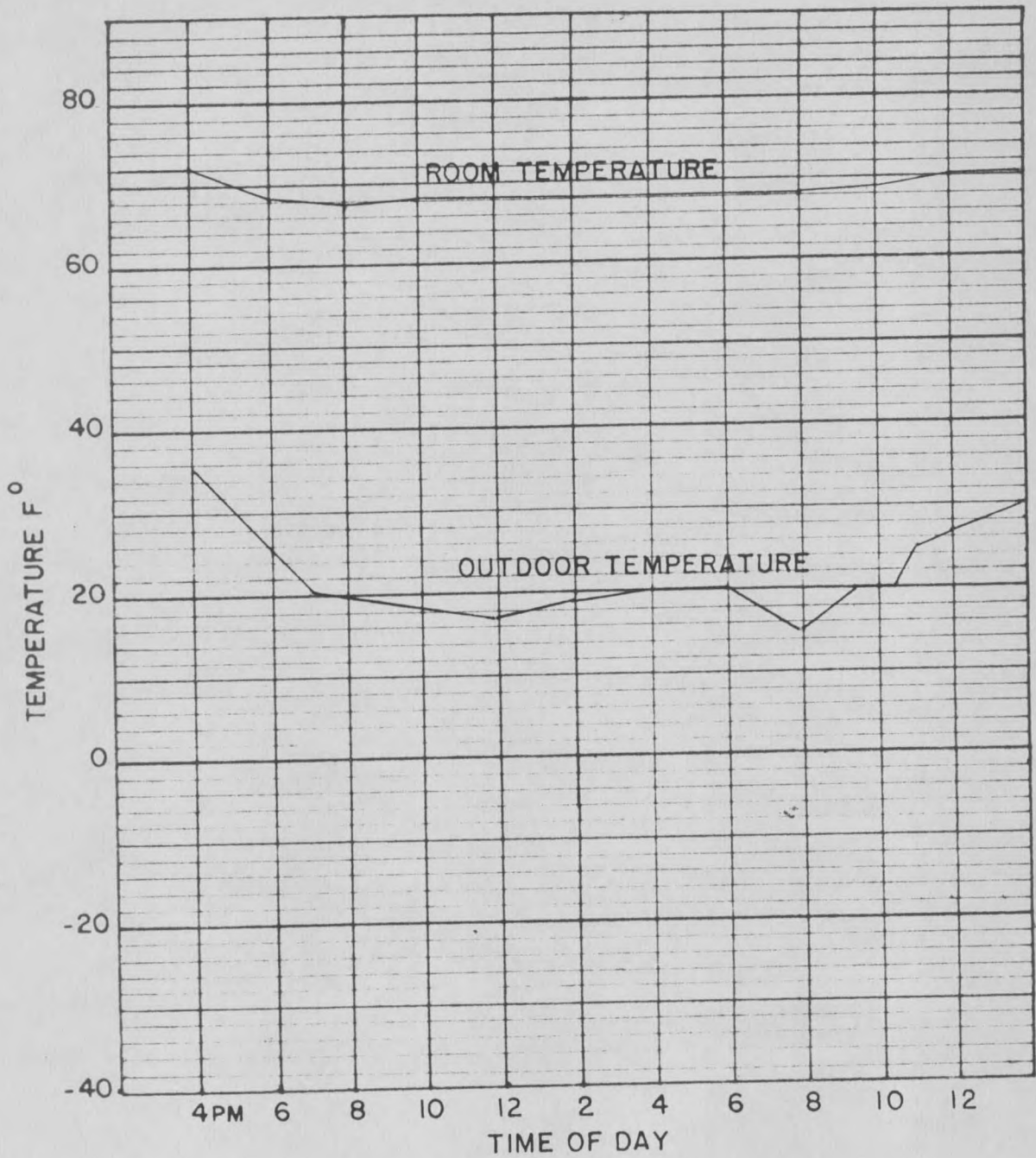

MERCOID LOW VOLTAGE ROOM THERMOSTAT  
INTERMITTENT CIRCULATION

FIG. 45

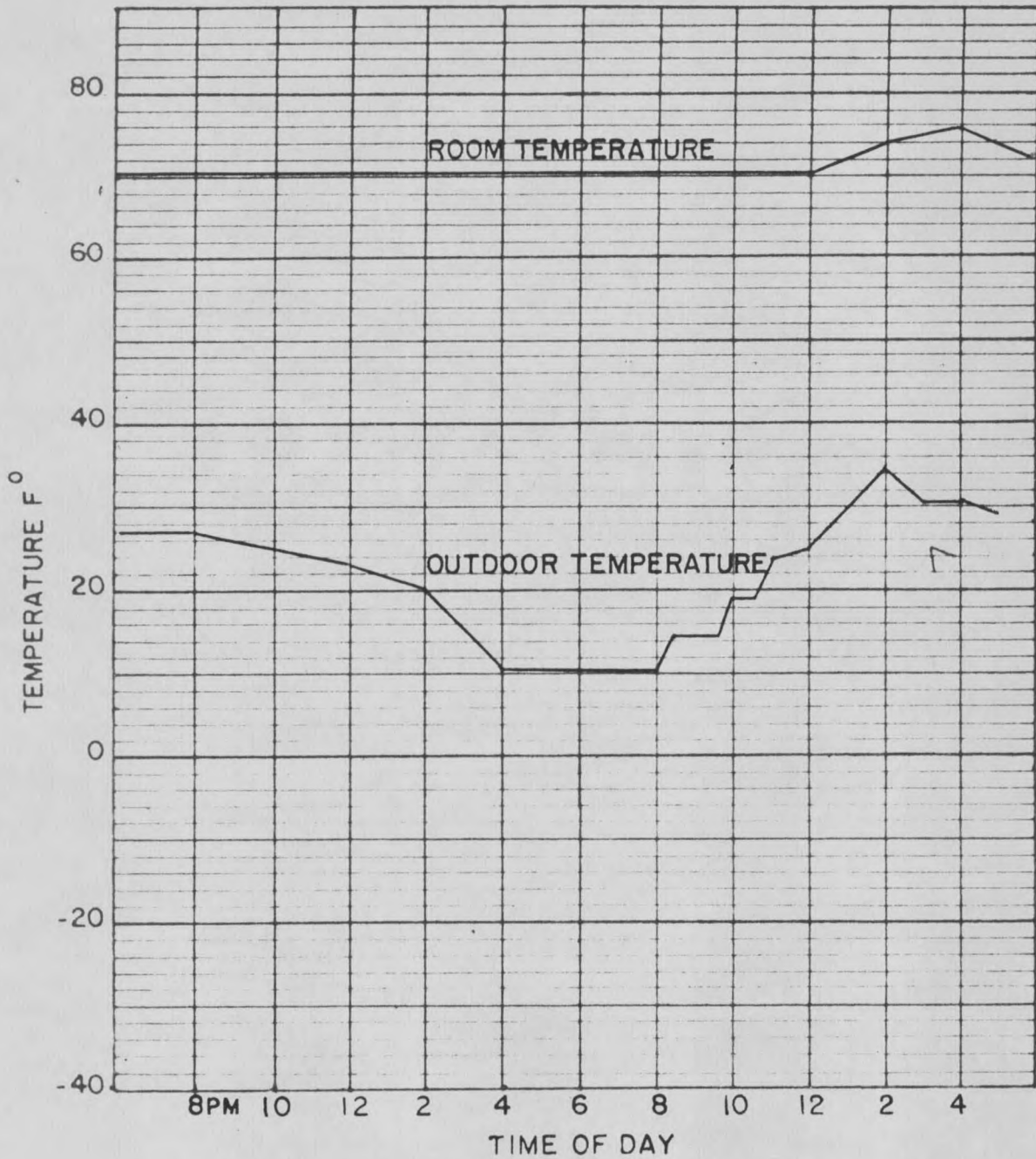

WHITE ROGERS LOW VOLTAGE HEAT ANTICIPATING THERMOSTAT  
INTERMITTENT CIRCULATION

FIG. 46

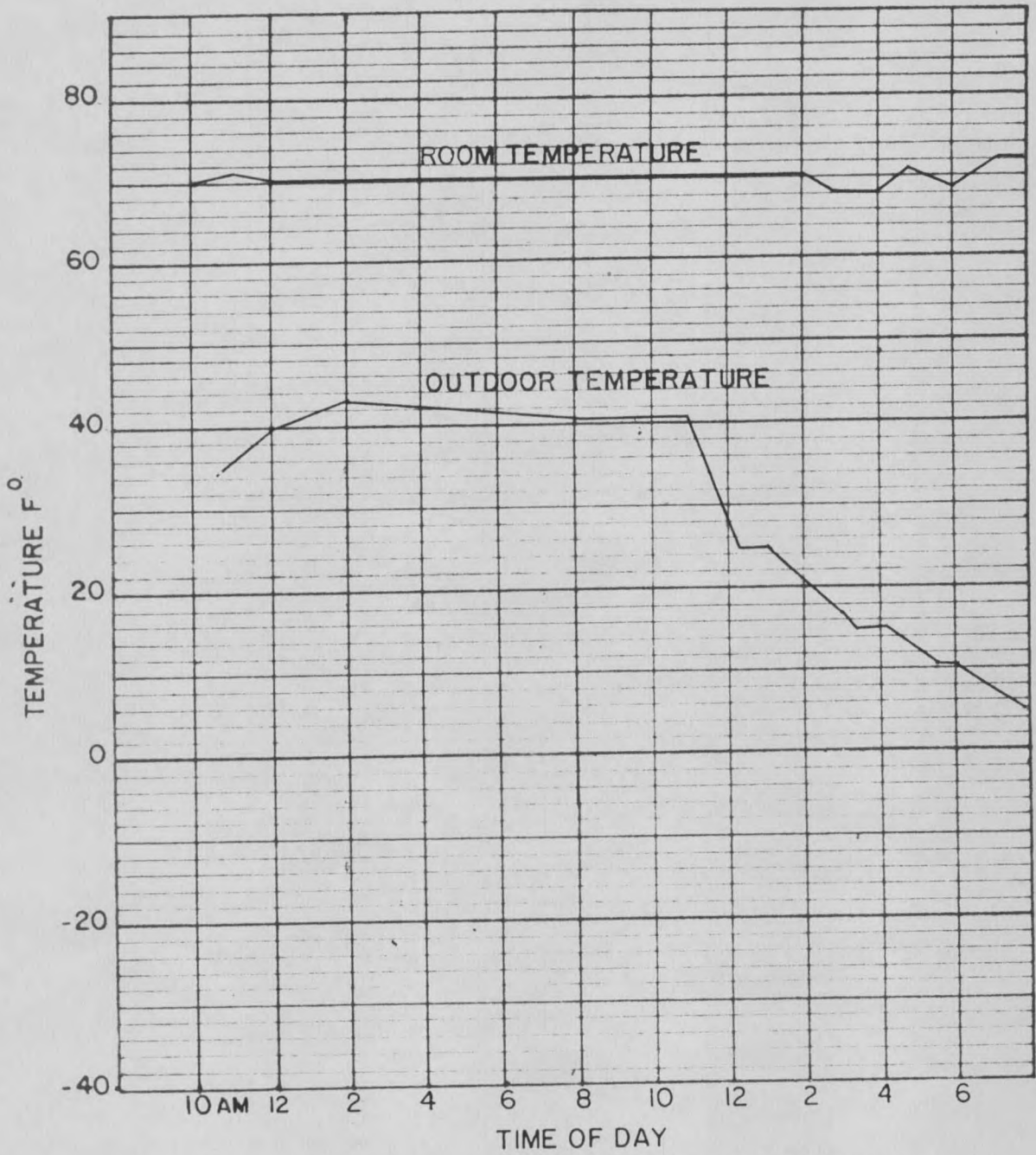

MINNEAPOLIS-HONEYWELL THREE-WIRE THERMOSTAT  
INTERMITTENT CIRCULATION

FIG. 47

1

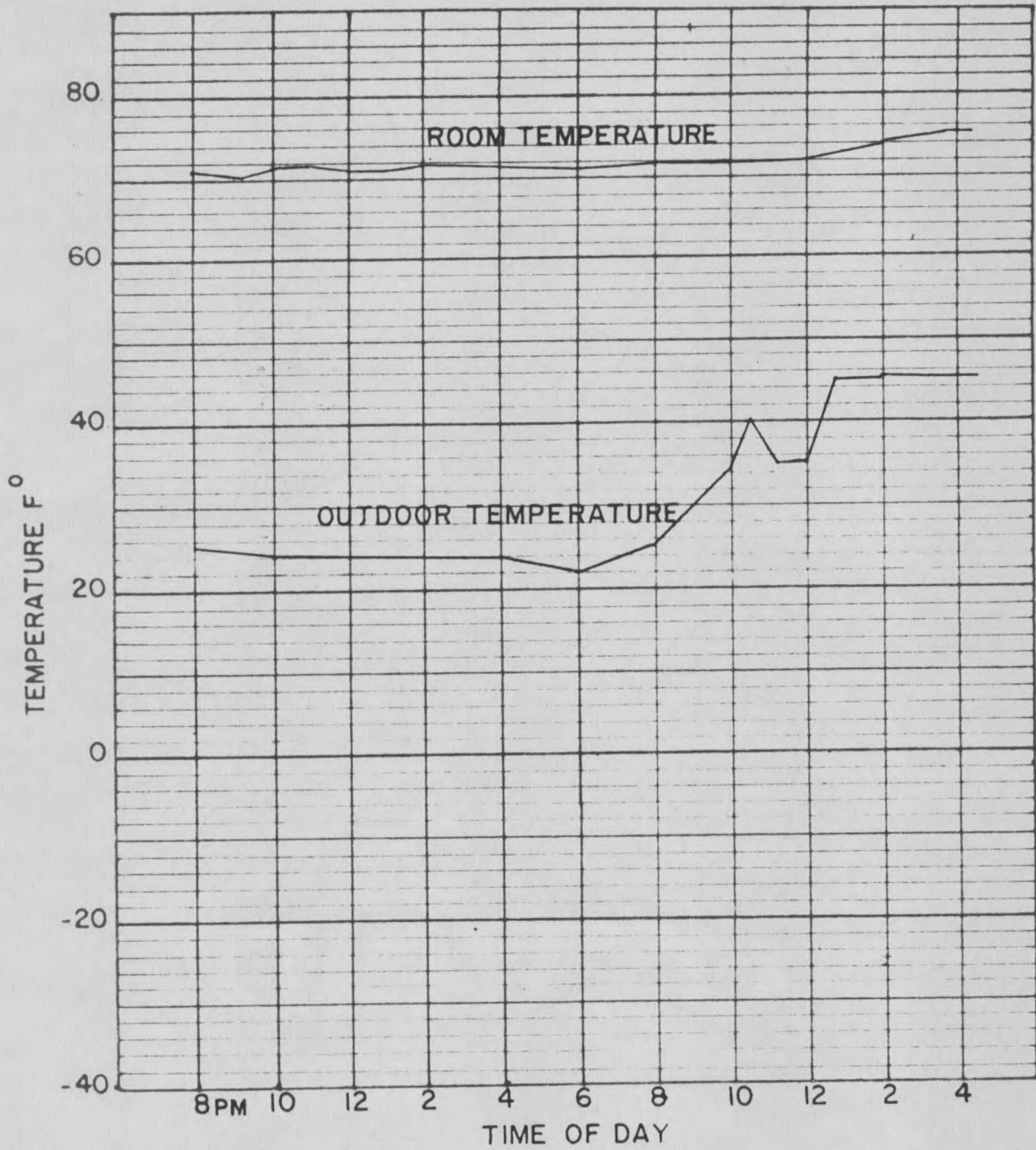

PENN LOW VOLTAGE THERMOSTAT CONTROLLING BURNER  
CONTINUOUS CIRCULATION

FIG. 48

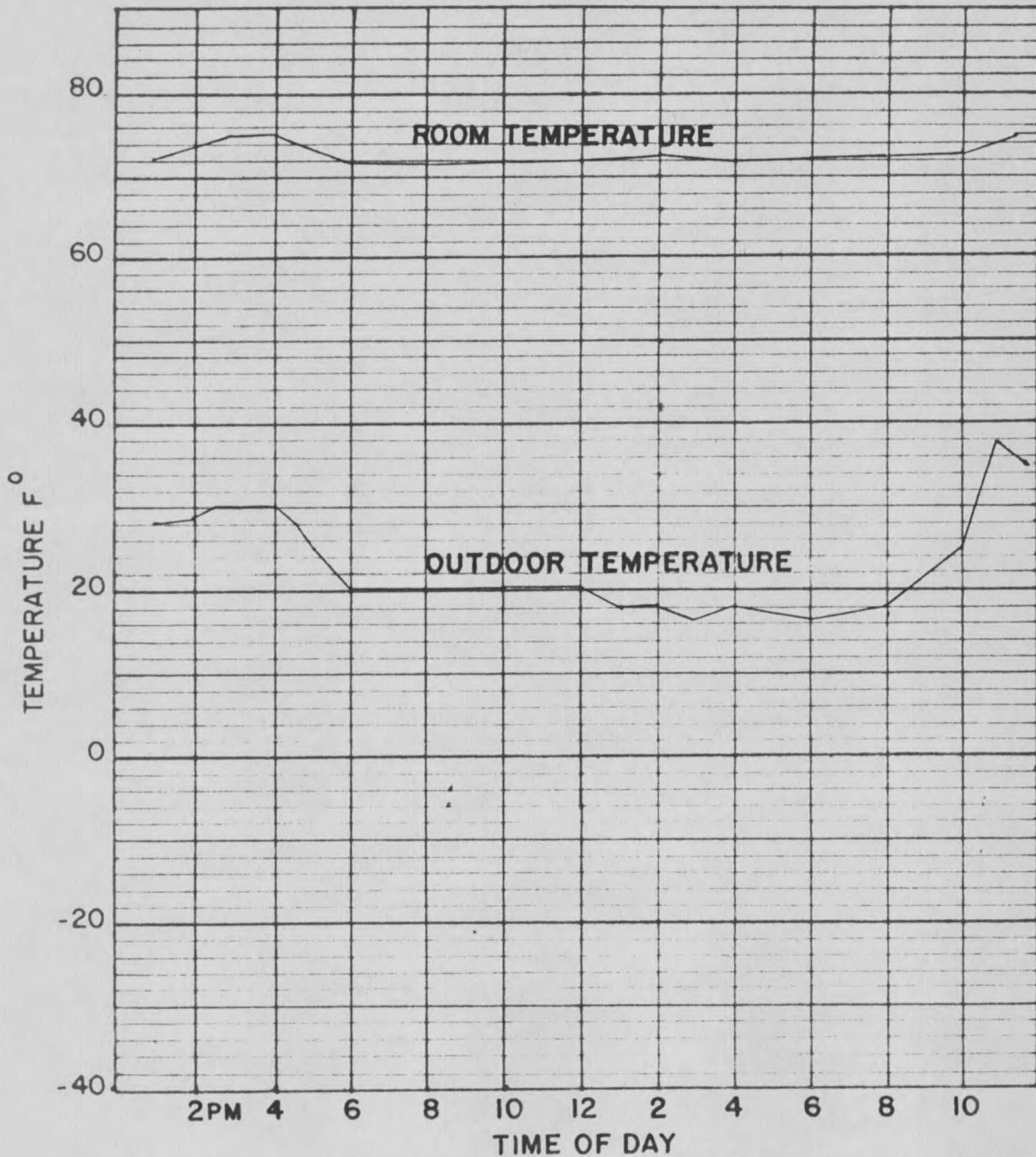

PENN 110 VOLT HEAT ANTICIPATING THERMOSTAT  
INTERMITTENT CIRCULATION

FIG. 49

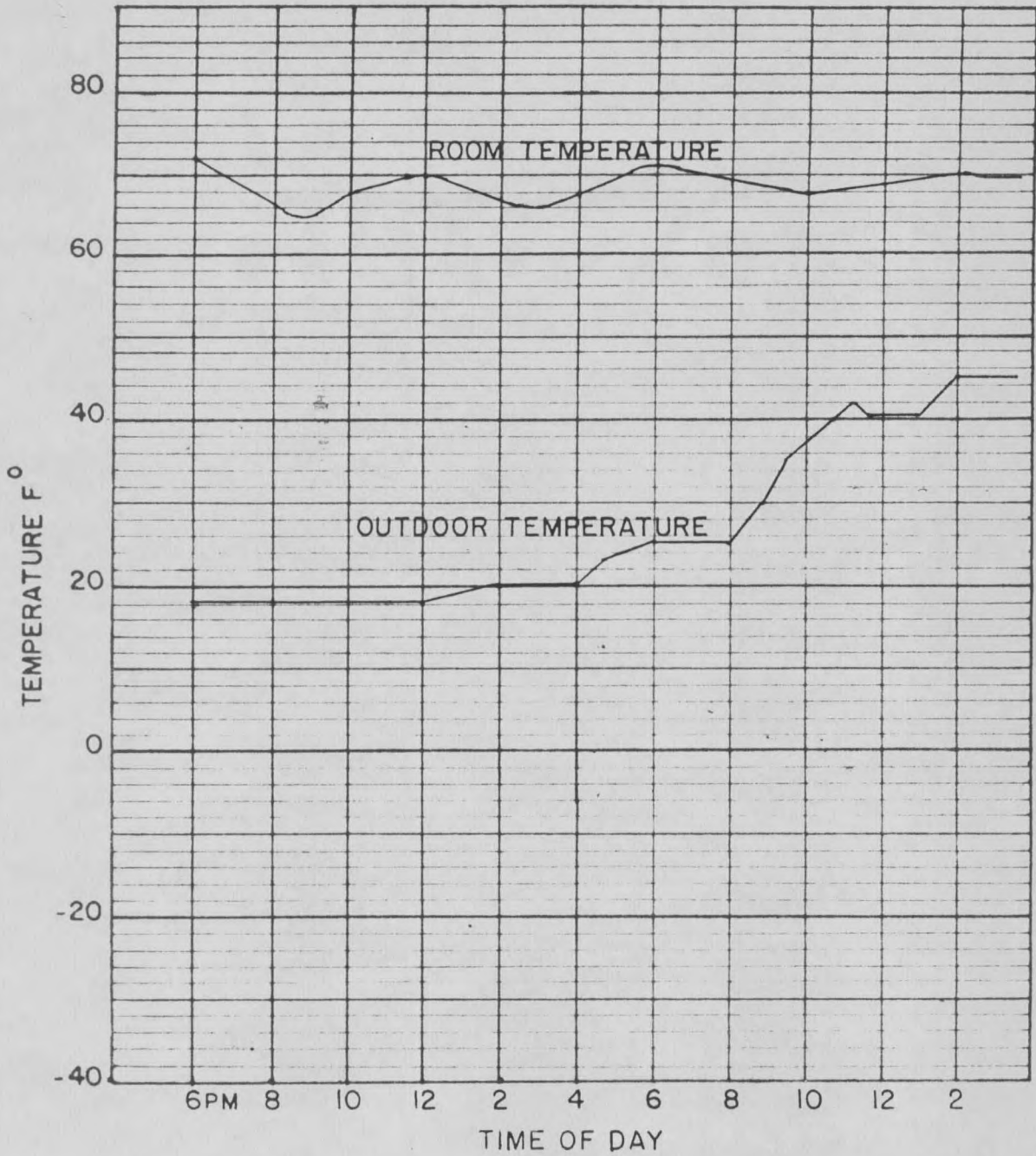

PERFEX 110 VOLT BELLOWS ACTUATED THERMOSTAT  
INTERMITTENT CIRCULATION

FIG. 50

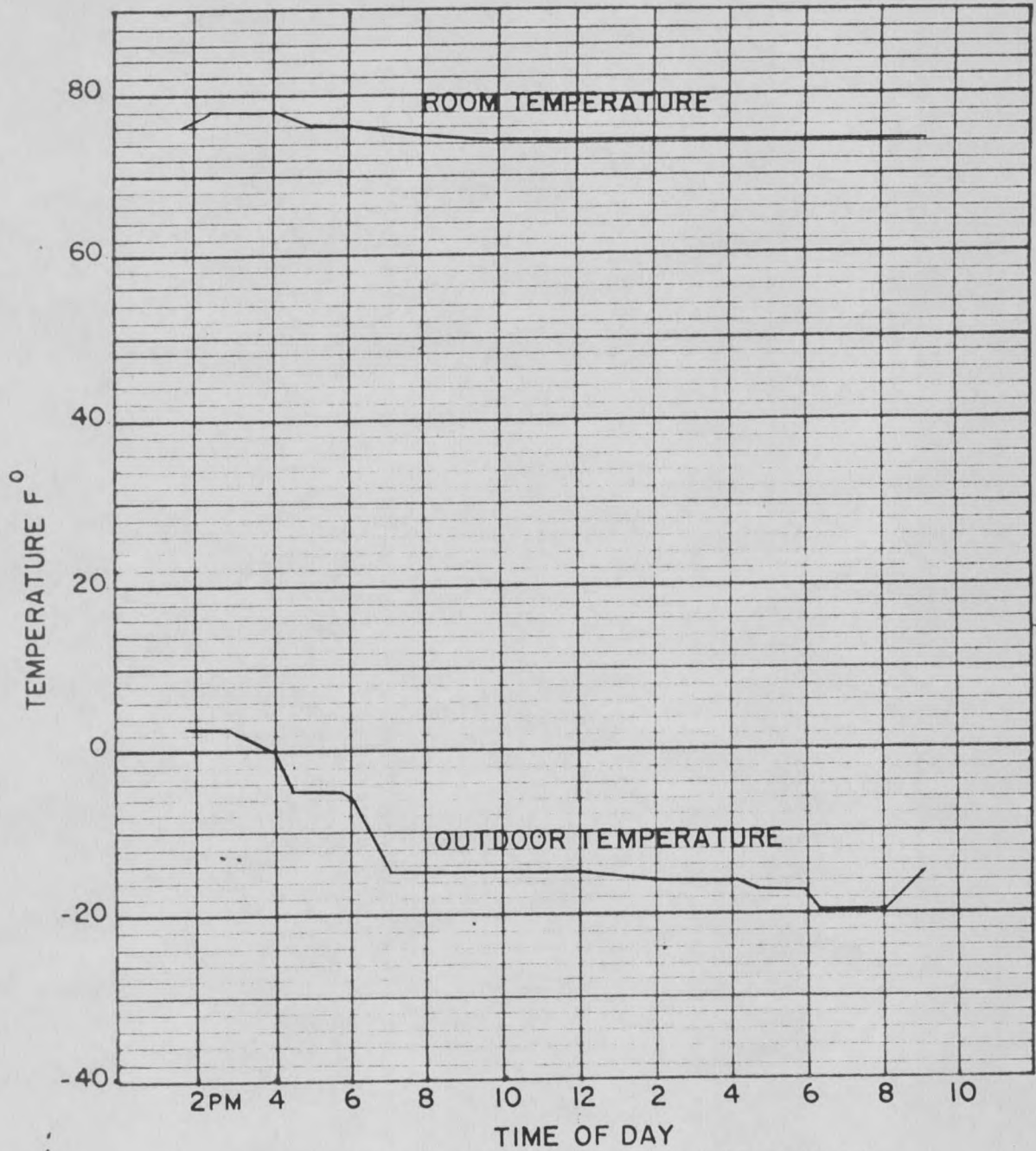

THRUSH RADIANT HEAT THERMOSTAT  
INTERMITTENT CIRCULATION

FIG. 51

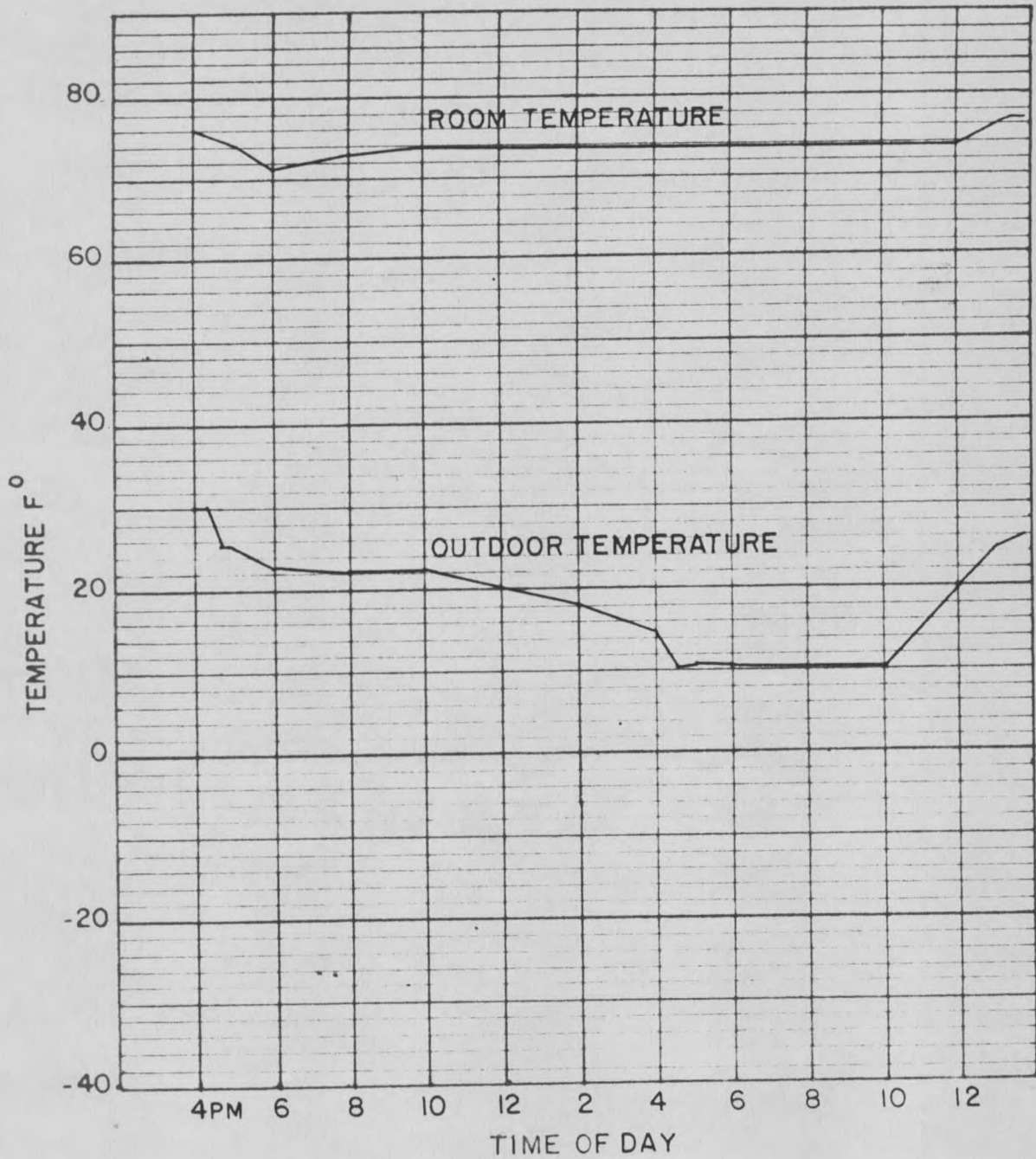

MINNEAPOLIS-HONEYWELL ELECTRONIC MODUFLOW

FIG. 52

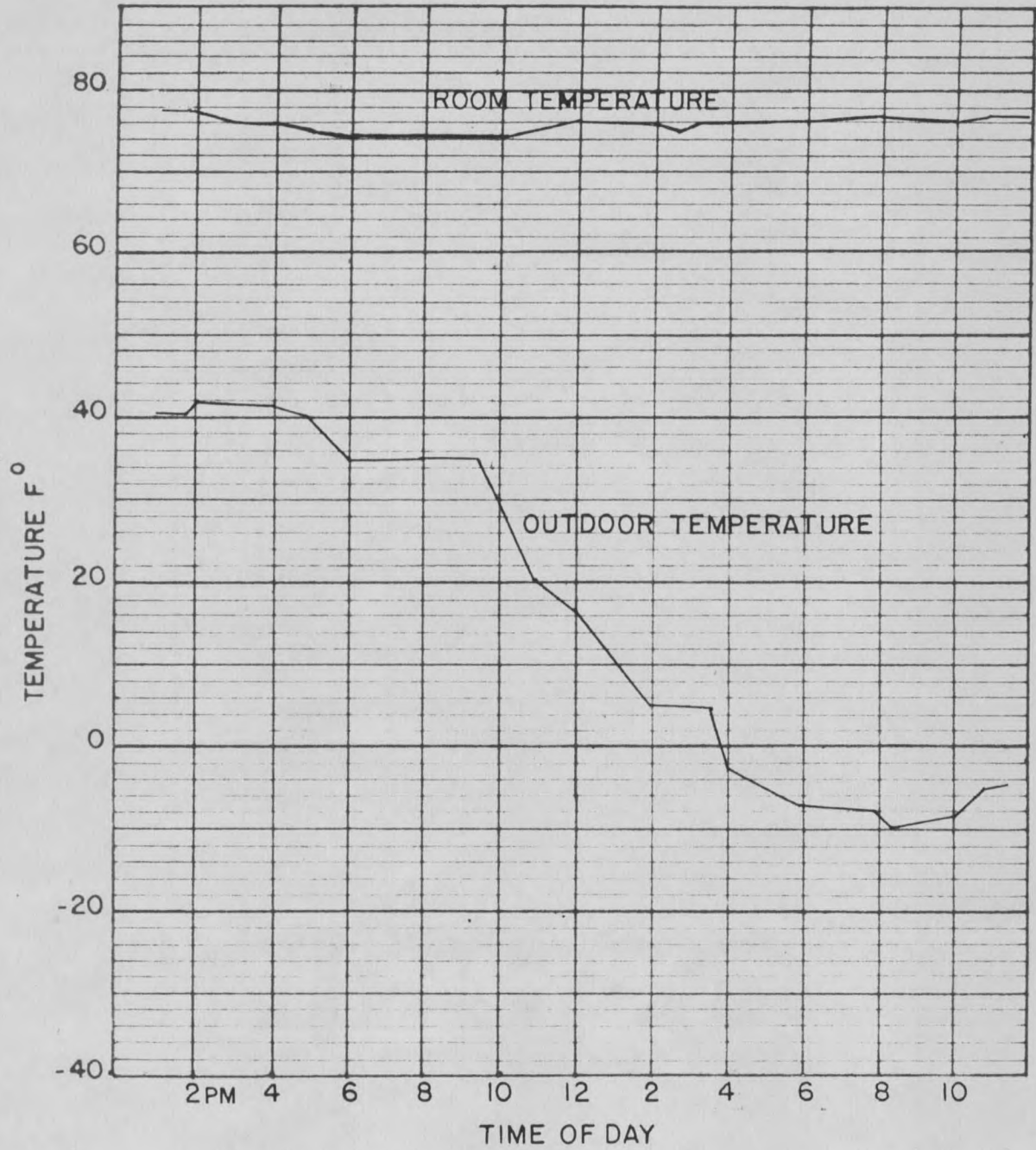

WHITE-ROGERS INDOOR-OUTDOOR CONTROL

FIG. 53

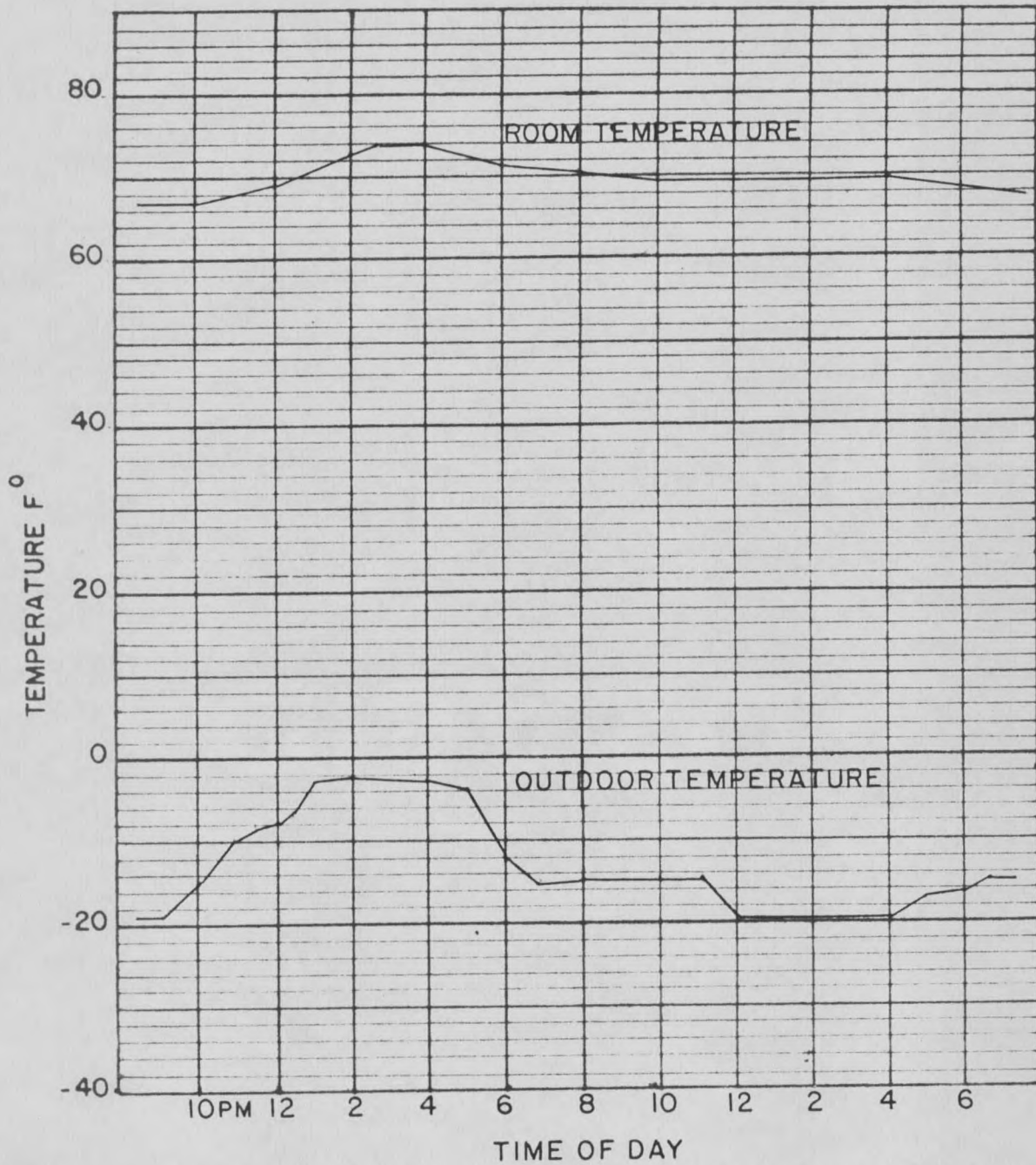

SARCOTHERM VALVE WITH THERMORAY THERMOSTAT

FIG. 54

From these charts it may be seen that there is no significant difference among the controls tested except the Perfex bellows-operated thermostat. This thermostat is a heavy-duty line-voltage type and because of its thermal lag, hunting resulted as shown in Figure 50.

A comparison between Figure 44 and Figure 48 shows that there is no difference in control with intermittent or continuous circulation.

All of the other charts show a temperature rise of from 4 degrees to 6 degrees occurring in the afternoon.

### Discussion

Although the outdoor temperature rose when the indoor temperature went up in the afternoon for all of the tests conducted in the Radiant Heating Laboratory, the room temperature rise occurred either slightly before or simultaneous to the outdoor rise. This would indicate that the radiation from the afternoon sun was upsetting the control rather than outdoor temperature. Further indication of this is given in Figure 45 and Figure 47. In the test in Figure 45 the second afternoon was overcast and the room temperature only rose 2 degrees compared to 4 degrees for the previous bright afternoon. Figure 47 shows a 3-degree afternoon room temperature rise with a rapid drop in outdoor temperature.

From experience with actual radiant heated residences, a morning temperature rise was noticeable. Since the Radiant Heating Laboratory is shielded from morning sun by Ryon Laboratory, the tests did not show this morning rise. For that reason it was decided to repeat part of the tests in the Wessel residence and in the Danforth Chapel.

Tests Conducted in the Residence of David Wessel and the Danforth Chapel

Description

The Wessel residence faces south with the living room where the tests were conducted at the front. The south wall of the living room is a window wall of Thermopane. The floor is constructed of 4 inches of concrete with 3/8-inch copper tubing at an 8-inch spacing buried 2 inches deep in the concrete.<sup>1</sup>

The Danforth Chapel faces east and the east wall is a Thermopane window wall. The floor is constructed of 4 inches of concrete with 1/2-inch copper tubing at an average spacing of 9 inches buried 2 inches deep in the concrete.<sup>2</sup>

Test Procedure

The room temperature was recorded on a 24-hour chart with a Brown Electronik potentiometer type recorder. The temperature sensing element was a 30-gage iron constantan thermocouple. This light gage thermostat wire was used to give rapid response. The measuring junction was placed so that it would not receive direct sun rays. The outdoor temperature was recorded with an Auto Lite recording thermometer mounted on the north wall of Ryon Laboratory. Intermittent circulation was used for all of the indoor control tests. Continuous circulation was used with the Sarcotherm valve as recommended by the manufacturer. The Sarcotherm tests were run in the Danforth Chapel, all others at the Wessel residence.

---

<sup>1</sup>Classen, Leo. 1951. RADIANT HEATING DESIGN AND TESTING.

<sup>2</sup>Horpedahl, L. G. 1950. RADIANT HEATING INSTALLATIONS IN MONTANA.

Results

Figures 55 through 59 show typical charts of the controls tested for sunny days.

All of the controls tested at the Wessel residence show a temperature rise in the morning from 10 degrees to 12 degrees.

The Sarcotherm valve with the Thermoray thermostat test in Danforth Chapel shows a 16-degree rise in the early morning. The abrupt drop starting at 10 a.m., Figure 59, was caused by workmen opening the doors.

From both the Wessel tests and the Chapel tests, it may be seen that the room temperature rise occurs before there is a rise in outdoor temperature. This indicates that the radiation from the sun is a major factor in control of the room temperature.

PARSONS BOND

100% COTTON FIBER

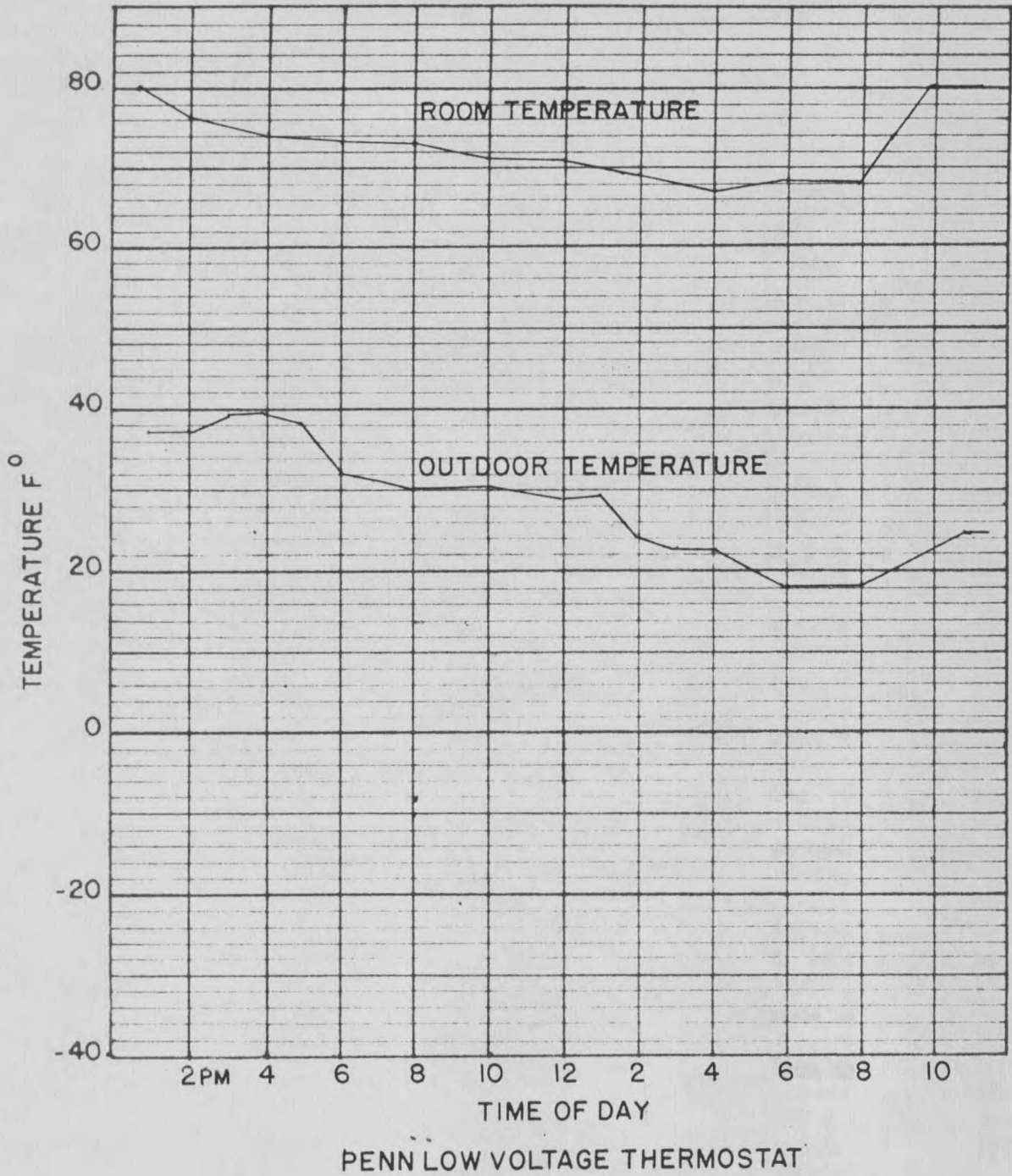
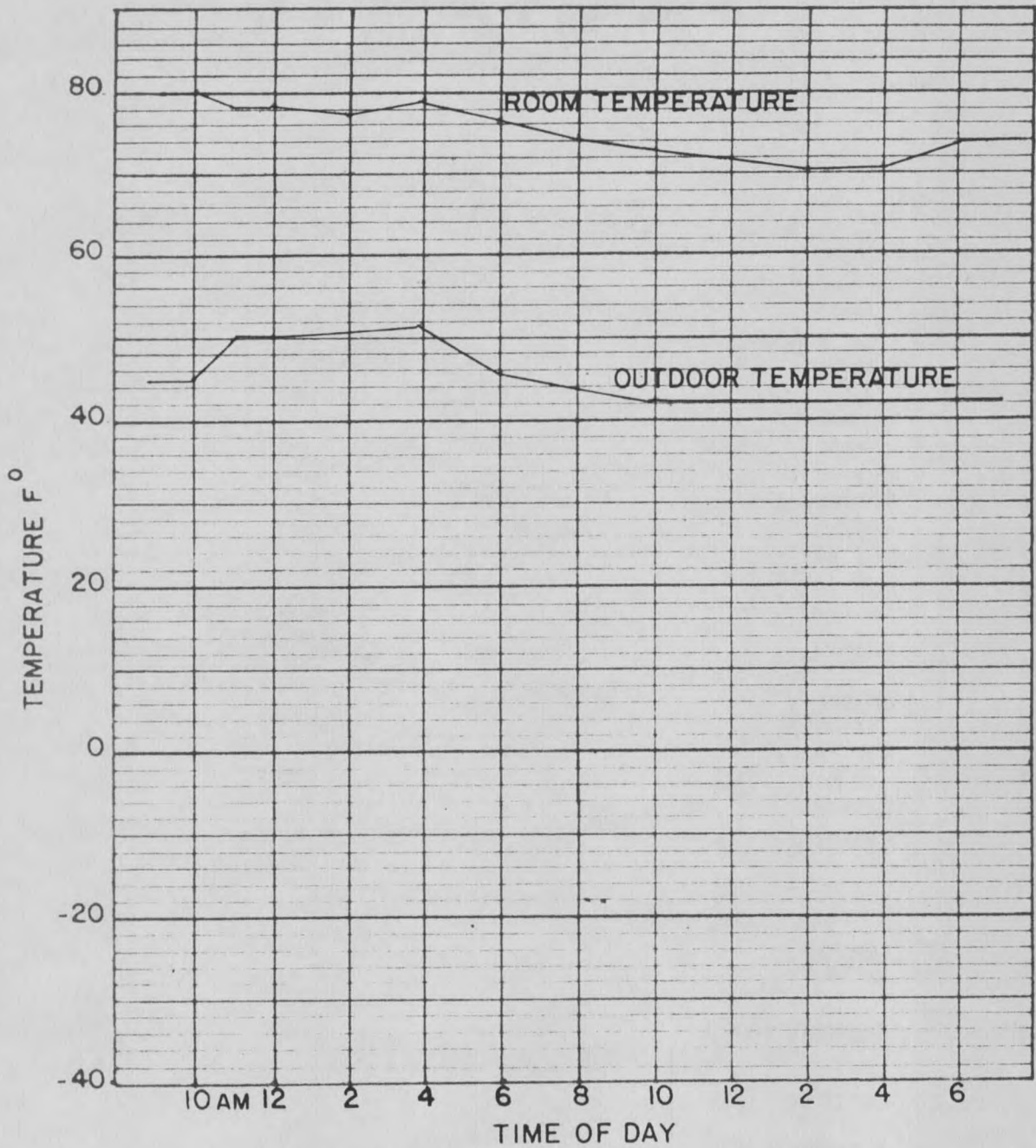
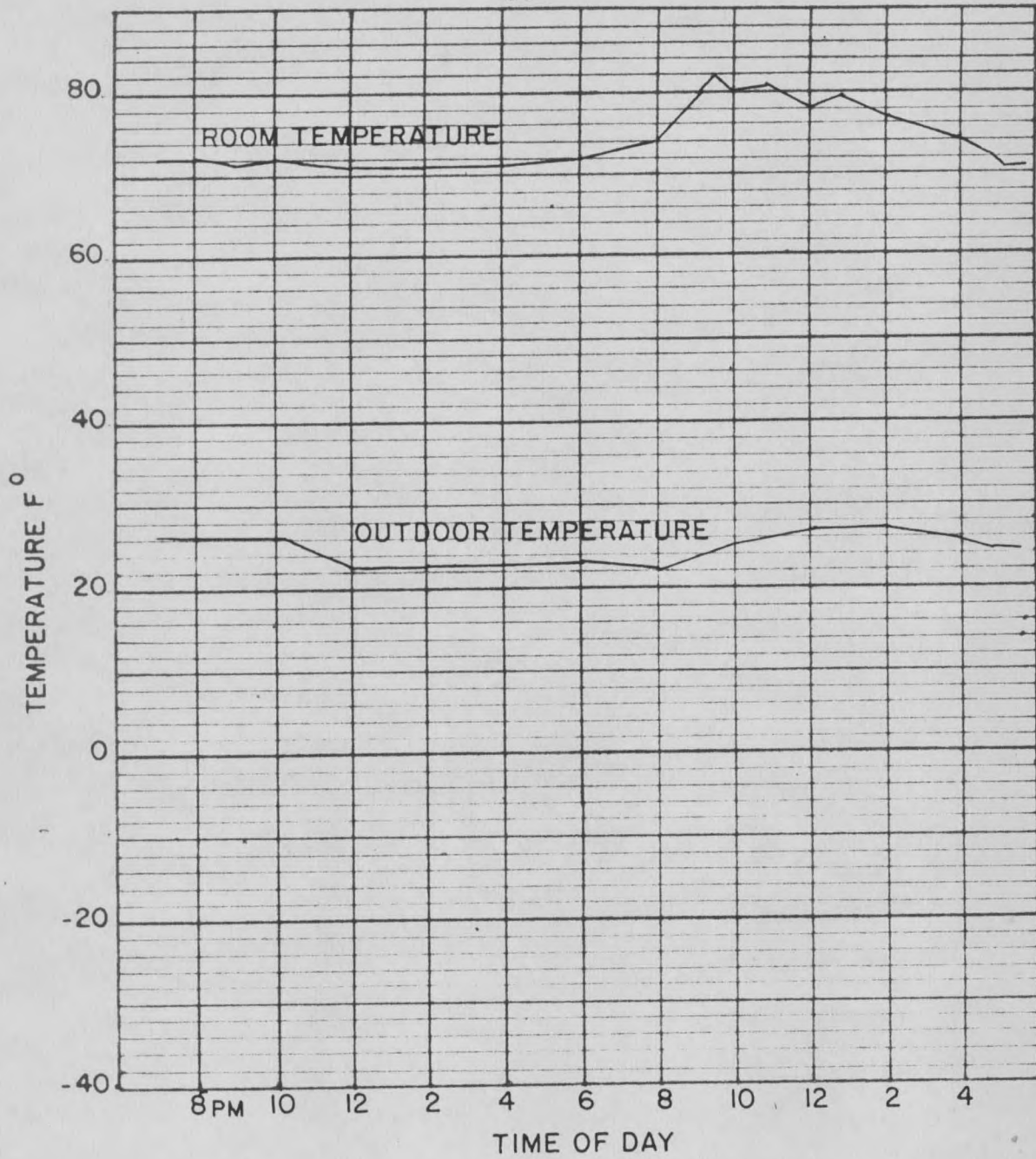

FIG. 55



DETROIT LUBRICATOR ROOM THERMOSTAT  
110 VOLT NO HEAT ANTICIPATION

FIG. 56



PENN 110 VOLT THERMOSTAT

FIG. 57

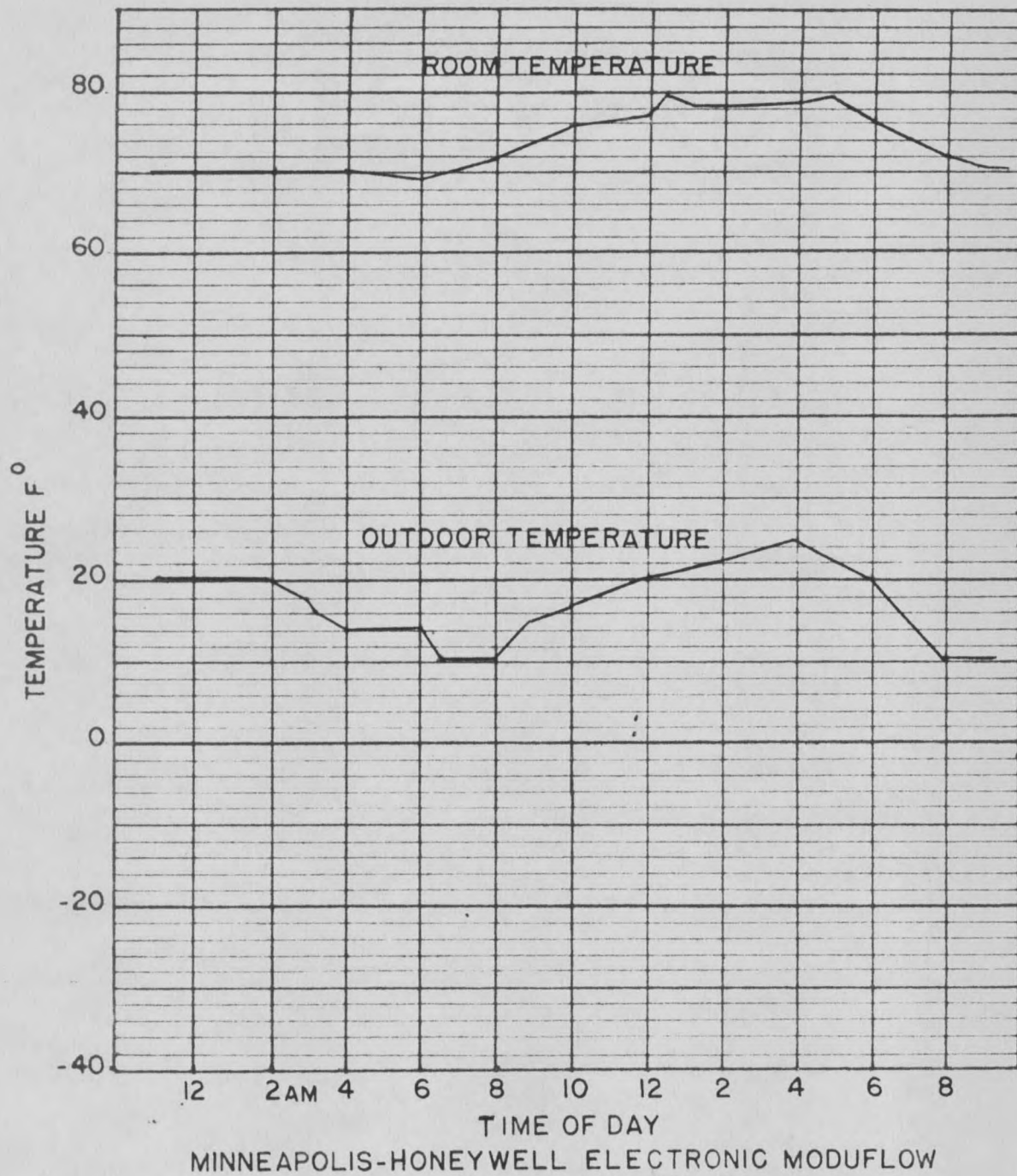
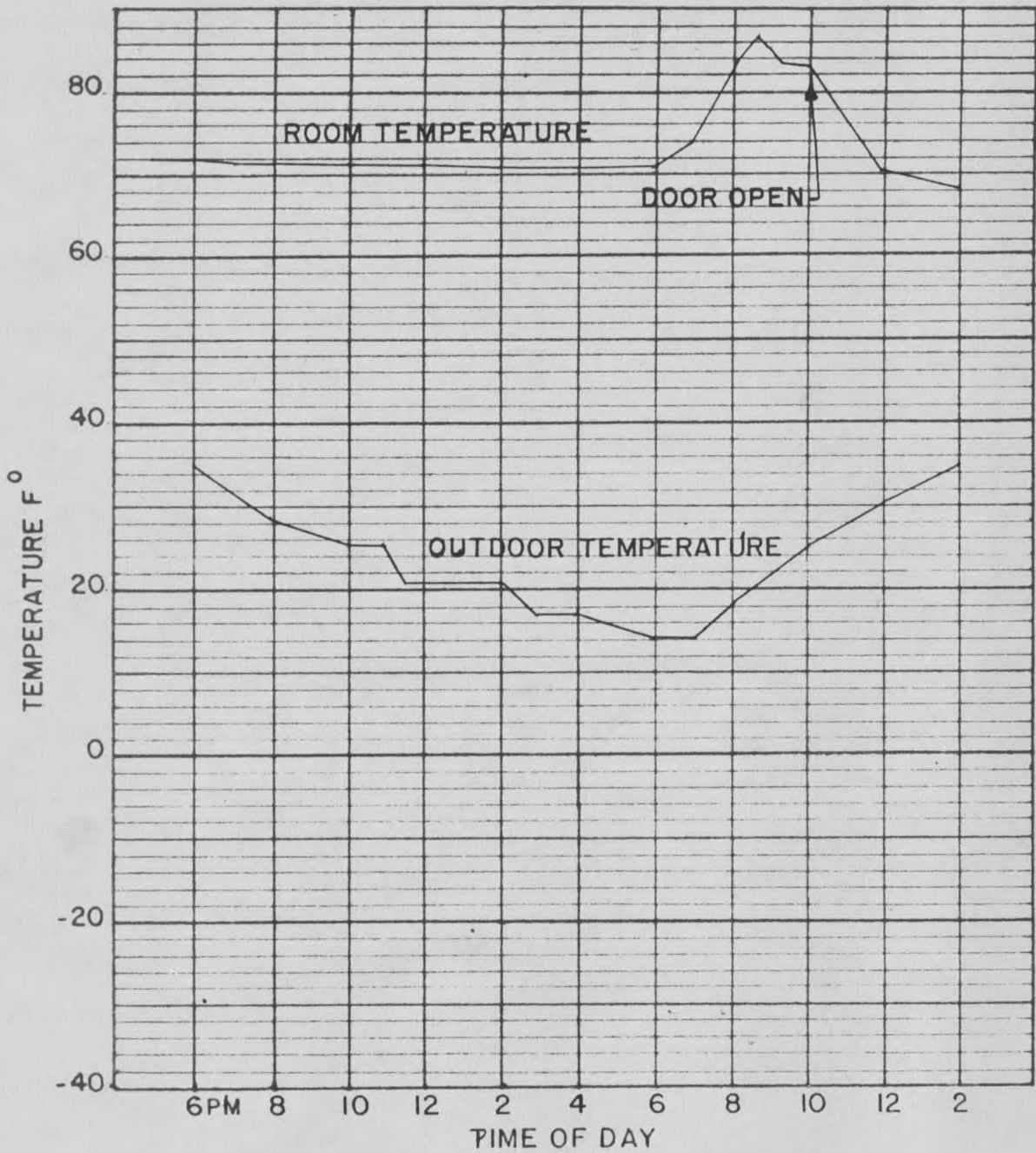

FIG. 58



SARCOTHERM VALVE WITH THERMORAY THERMOSTAT

FIG. 59

### Conclusions

1. None of the controls tested are satisfactory for radiant heating with floor panels since a 10-degree to 16-degree temperature rise occurs in the early morning.
2. A simple bimetal operated 110-volt room thermostat with intermittent circulation is as good as any of the controls tested since it has the lowest cost and power consumption and it gives equal results.

### Discussion

To eliminate the temperature rise occurring on bright mornings a control is needed to turn the heating system off well before sunrise. This control must also prevent an excessive drop in temperature on cloudy days. Some people have complained about a chilling effect felt after the sun has set. This could be eliminated by a control that would start the system before sunset.

Heating controls should be readily adjusted by the occupants who may have little knowledge of their operation. The indoor-outdoor controls on the market today require careful adjustment and this adjustment is difficult to make. Even with temperature recorders to give a visual record, it took as long as 3 hours to adjust the Electronic Modu-flow control and 5 days to adjust the Sarcotherm mixing valve.

A control is now being developed in the Mechanical Engineering Department that will eliminate the morning temperature rise, maintain the proper daytime temperature, eliminate any early evening chilling effect and be readily adjusted by anyone.

LITERATURE CONSULTED

- Adlam, F. N. RADIANT HEATING. 1947.
- American Society of Heating and Ventilating Engineers. GUIDE. 1949, 1950, 1951, 1952.
- Bell and Gossett Company. BELL AND GOSSETT HANDBOOK. 1949.
- Chase Brass and Copper Company. SUGGESTIONS FOR DESIGNING RADIANT PANEL HEATING WITH COPPER TUBE. 1948.
- Classen, Leo. RADIANT HEATING DESIGN AND TESTING. 1951.
- Detroit Lubricator Company. AUTOMATIC CONTROLS FOR GAS HEATING, CATALOG G. 1950.
- Fenwal, Inc. FENWAL THERMOSWITCH INSTRUCTION MANUAL. 1950.
- General Controls. GENERAL CATALOG. 1951.
- Hoffman Specialty Company. HOFFMAN ENGINEERING NEWS, PANEL HEATING. 1946.
- Horpedahl, L. G. RADIANT HEATING INSTALLATIONS IN MONTANA. 1950.
- Jennings, B. H., and Lewis, S. R. AIR CONDITIONING AND REFRIGERATION. 1950.
- Minneapolis-Honeywell Regulator Company. AUTOMATIC CONTROL OF RADIANT PANEL HEATING.
- Minneapolis-Honeywell Regulator Company. AUTOMATIC HEATING CONTROLS, CATALOG AND PRICE LIST. 1951-1952.
- Penn Controls, Inc. GENERAL CATALOG. 1947.
- Penn Controls, Inc. BULLETIN 1508K. 1949.
- Perfex Corporation. TWIN CONTACT CONTROLS HANDBOOK. 1950.
- Sarcotherm Controls, Inc. WEATHER CONTROL FOR HOT WATER AND RADIANT HEATING. 1948.
- Sarcotherm Controls, Inc. WEATHER CONTROL TECHNICAL BULLETIN #3. 1949.
- Schoemaker, R. W. RADIANT HEATING. 1948.

Steel Pipe Research Committee, American Iron and Steel Institute.  
RADIANT PANEL HEATING WITH STEEL PIPE. 1951.

Thrush, H. A., and Company. HOT WATER ENGINEERING AND INSTALLATION DATA.

White-Rogers Electric Company. HEATING CONTROLS CATALOG AND INSTRUCTIONS.  
1950.



3 1762 10014536 4

N378  
H948t

cop.2

102996

**AUTHOR**  
Hurtle, James F.  
**TITLE** Temperature controls for radiant heating with floor panels.

DATE DUE	BORROWER'S NAME
	Jim M. H. Landrum
10-25-63	Richard R. [unclear]
6/25/65	Don Larson

N378  
H948t  
cop.2

102996