



A kinematic analysis of a telemark ski turn  
by Thomas Allen Trafton, Jr

A thesis submitted in partial fulfillment of the requirements for the degree Of Master of Science in  
Health and Human Development  
Montana State University  
© Copyright by Thomas Allen Trafton, Jr (1998)

**Abstract:**

Sondre Nordheim, born in 1825 in the town of Telemark, Norway developed the telemark ski turn. Little experimental data has been collected on the sport of telemark skiing. The purpose of this study was to determine the kinematics of a telemark ski turn including joint angles, joint ROM, and position changes of the lower extremity and trunk. Five, advanced level, male telemark skiers (29 + 8.1 yrs) volunteered and gave written informed consent to all testing procedures. A single telemark ski turn was analyzed using 3-D videography.

The two 2-D images were transformed to create a 3-D model using the DLT technique. Two coordinate systems were used to calculate the kinematic data. Descriptive characteristics and summary statistics were calculated for the kinematic data. All subjects showed similar characteristics and kinematic patterns during the ski turn. A telemark turn sequence was created from the averages of the five skiers. Movements and position changes of feet, ankles, knees, hips, trunk; shoulders, and COM were analyzed and described during the turn progression. ROM and joint angles were also used to analyze and describe the ski progression. The telemark skier works more like a flexible linked because the heel is not fixed to the ski allowing a greater ROM of the hips, knees, and ankles compared to alpine skiing. The telemark turn produced hip flexion ROM of  $38 + 17.1$  for the inside/uphill leg and  $27 \pm 12.0$  for the downhill/outside leg, greater than alpine skiing results. Telemark skiers demonstrated greater hip flexion than alpine skiers when comparing maximum and minimum hip flexion angles for the inside and outside legs. Telemark skiers had knee flexion range from  $88 \pm 6.8$  to  $124 \pm 7.1$  degrees for the uphill knee and  $100 + 3.9$  to  $119 \pm 5.2$  for the downhill knee greater than the results from alpine skiing. Differences from previous literature include the following; movements of the hips, knees and ankles near the completion of the sequence, pole plant occurring before the feet become parallel, and the forward to aft foot displacement during the turn.

A KINEMATIC ANALYSIS OF A TELEMAR SKI TURN

by

Thomas Allen Trafton, Jr.

A thesis submitted in partial fulfillment  
of the requirements for the degree

of

Master of Science

in

Health and Human Development

MONTANA STATE UNIVERSITY-BOZEMAN  
Bozeman, Montana

August 1998

© COPYRIGHT

by

Thomas Allen Trafton, Jr.

1998

All Rights Reserved



## STATEMENT OF PERMISSION TO USE

In presenting this thesis in partial fulfillment of the requirements for a master's degree at Montana State University-Bozeman, I agree that the Library shall make it available to borrowers under rules of the Library.

If I have indicated my intention to copyright this thesis by including a copyright notice page, copying is allowable only for scholarly purposes consistent with "fair use" as prescribed in the U.S. Copyright Law. Requests for permission for extended quotation from or reproduction of this thesis in whole or in parts may be granted only by the copyright holder.

Signature Thomas A. Kraft 2  
Date 8/31/98

## TABLE OF CONTENTS

<b>CHAPTER I INTRODUCTION</b> .....	1
STATEMENT OF PURPOSE.....	2
SIGNIFICANCE.....	2
DESCRIPTIVE GOALS.....	4
DELIMITATIONS OF THE STUDY.....	4
LIMITATIONS OF THE STUDY.....	4
ASSUMPTIONS.....	5
DEFINITIONS.....	5
<b>CHAPTER II REVIEW OF LITERATURE</b> .....	7
INTRODUCTION.....	7
SKI DESIGN.....	7
PHYSICS OF SKIING.....	8
<i>Basic Physics</i> .....	8
A. The initiation of motion.....	8
B. Controlling speed.....	9
<i>The Physics of Turning</i> .....	9
A: External forces of a turn.....	9
B. Angulation.....	10
C. Unweighting.....	13
1. Up unweighting.....	13
2. Down unweighting.....	13
D. Technique.....	14
1. Down - up - technique.....	14
2. Up - down technique.....	14
3. Rotation.....	15
THE TELEMARSK SKI TURN.....	16
<i>Phase I</i> .....	17
<i>Phase II</i> .....	19
<i>Phase III</i> .....	20
<i>Phase IV</i> .....	21
INJURIES.....	22
<i>Alpine Skiing</i> .....	22
<i>Cross-country Skiing</i> .....	24
<i>Telemark Skiing</i> .....	26
<b>CHAPTER III METHODOLOGY</b> .....	27
INTRODUCTION.....	27
PILOT STUDIES.....	27
SUBJECTS.....	28
EXPERIMENTAL PROTOCOL.....	30
DATA COLLECTION.....	30
INSTRUMENTATION.....	33
DATA REDUCTION.....	35
DATA ANALYSIS.....	37
DESCRIPTIVE RESULTS.....	42
SUMMARY.....	43
<b>CHAPTER IV RESULTS</b> .....	44
INTRODUCTION.....	44
SEQUENCE.....	44

LOWER EXTREMITY .....	46
HIPS .....	51
UPPER EXTREMITY .....	59
DISCUSSION .....	65
INTRODUCTION .....	65
PHYSICS PRINCIPLES .....	65
<i>Telemark Position and Equipment</i> .....	65
<i>Movements of the COM</i> .....	67
<i>Rotary Movements</i> .....	68
<i>Sequence</i> .....	69
<i>Telemark ROM</i> .....	70
A. Hip .....	70
B. Knee and ankle .....	71
KINEMATICS .....	77
SUMMARY .....	84
CONCLUSIONS AND RECOMMENDATIONS .....	88
APPENDIX A CONSENT FORMS .....	91
SUBJECT CONSENT FORM FOR PARTICIPATION IN HUMAN RESEARCH MONTANA STATE UNIVERSITY .....	91
SUBJECT CONSENT FORM FOR PERMISSION TO RETAIN FILM FOR EDUCATIONAL PURPOSES .....	93
APPENDIX B SMOOTHING PARAMETERS .....	94
APPENDIX C DEFINITIONS AND EQUATIONS .....	95
DEFINITION OF FORCES FOR FIG. 2.1 .....	95
EQUILIBRIUM EQUATIONS FIG. 5.7 .....	95
EQUILIBRIUM EQUATIONS FOR FIG. 5.9. SAGITTAL DIAGRAM. ....	95
EQUILIBRIUM EQUATIONS FOR FIG. 5.10. FRONTAL DIAGRAM. ....	96
REFERENCES CITED .....	97

**LIST OF TABLES**

Table 3.1. Body mass, stature, and age.....	29
Table 3.2. Ski length and type of ski used.....	29
Table 3.3. Anatomical landmarks for kinematic markers.....	31
Table 4.1. Ankle flexion angles.....	48
Table 4.2. Knee flexion angles.....	50
Table 4.3. Hip flexion angles.....	51
Table 4.4. Hip abduction and adduction angles.....	53
Table 4.5. Leg rotation.....	54
Table 4.6. Hip segment rotation.....	59
Table 4.7. Shoulder rotation.....	60
Table 4.8. Shoulder segment tilt.....	61
Table 4.9. Forward lean.....	62
Table 4.10. Shift in the COM (center of mass).....	64

## LIST OF FIGURES

Figure 2.1. A diagram of the forces acting upon a telemark skier sliding straight down the fall line of the hill.....	8
Figure 2.2. The external forces acting on the body during a telemark ski turn. Force of lateral adhesion ( $F_{LA}$ ) and centrifugal force ( $F_C$ ).....	11
Figure 2.3. The telemark position, "double 90's".....	16
Figure 2.4. Body sequence progression during the telemark turn.....	18
Figure 2.5. Top view of the telemark sequence.....	23
Figure 3.1. Telemark boot and cable binding attached to ski.....	30
Figure 3.2. Telemark skier with markers in place.....	32
Figure 3.3. The ski course and reference frame viewed from above.....	34
Figure 3.4. Picture of the ski course looking downhill.....	35
Figure 3.5. Sagittal view of the control frame and bamboo poles.....	36
Figure 3.6. The two coordinate systems.....	38
Figure 3.7. Sagittal plane variables.....	39
Figure 3.8. Three frontal plane variables.....	40
Figure 3.9. Transverse plane diagram of leg and shoulder rotation.....	41
Figure 3.10. Diagram representing the amount of forward lean during the turn.....	42
Figure 3.11. Traverse plane hip rotation.....	43
Figure 4.1. The telemark turn sequence.....	45
Figure 4.2. Ankle ROM during the telemark turn.....	48
Figure 4.3. Position and acceleration of the COM.....	49
Figure 4.4. Knee ROM during the telemark turn.....	50

Figure 4.5. Hip flexion ROM during the telemark turn.....	52
Figure 4.6. Hip ab/adduction ROM during the telemark turn.....	53
Figure 4.7. Internal and external leg rotation during the telemark turn.....	55
Figure 4.8a. The relationship between flexion and ab/adduction of the right hip during the telemark turn.....	55
Figure 4.8b. The relationship between flexion and ab/adduction of the left hip during the telemark turn.....	56
Figure 4.9a. The relationship between flexion and rotation of the right leg during a telemark turn.....	56
Figure 4.9b. The relationship between flexion and rotation of the left leg during a telemark turn.....	57
Figure 4.10a. The relationship between rotation and ab/adduction of the right leg during a telemark turn.....	57
Figure 4.10b. The relationship between rotation and ab/adduction of the left leg during a telemark turn.....	58
Figure 4.11. The relationships between hip and shoulder rotation during a telemark turn.....	59
Figure 4.12. The relationship between shoulder tilt and shoulder rotation during a telemark turn.....	61
Figure 4.13. Trunk flexion angle during the telemark turn.....	63
Figure 4.14. Changes in the COM during a telemark turn.....	64
Figure 5.1. Photo of an alpine ski boot (left) and a telemark ski boot (right).....	66
Figure 5.2. Movement of the telemark boot in a telemark binding.....	67
Figure 5.3. Angulation of the telemark skier during a turn.....	69
Figure 5.4. Simulated right telemark turn front view (A). Body position and counter rotation of shoulder to hips (B).....	70
Figure 5.5. Position of an alpine skier.....	71

Figure 5.6. The body position of a telemark skier in the telemark position from the side.....	72
Figure 5.7. Free body diagram of an alpine skier leg with fixed ankle angle.....	73
Figure 5.8. Free body diagram of the telemark skier.....	74
Figure 5.9. A free body diagram of the trail leg during a telemark turn in the sagittal plane.....	75
Figure 5.10. A free body diagram of the trail leg during a telemark turn in the frontal plane.....	76
Figure 5.11. The velocity of a telemark skier turning during the sequence.....	80

## ABSTRACT

Sondre Nordheim, born in 1825 in the town of Telemark, Norway developed the telemark ski turn. Little experimental data has been collected on the sport of telemark skiing. The purpose of this study was to determine the kinematics of a telemark ski turn including joint angles, joint ROM, and position changes of the lower extremity and trunk. Five, advanced level, male telemark skiers ( $29 \pm 8.1$  yrs) volunteered and gave written informed consent to all testing procedures. A single telemark ski turn was analyzed using 3-D videography. The two 2-D images were transformed to create a 3-D model using the DLT technique. Two coordinate systems were used to calculate the kinematic data. Descriptive characteristics and summary statistics were calculated for the kinematic data. All subjects showed similar characteristics and kinematic patterns during the ski turn. A telemark turn sequence was created from the averages of the five skiers. Movements and position changes of feet, ankles, knees, hips, trunk, shoulders, and COM were analyzed and described during the turn progression. ROM and joint angles were also used to analyze and describe the ski progression. The telemark skier works more like a flexible linked because the heel is not fixed to the ski allowing a greater ROM of the hips, knees, and ankles compared to alpine skiing. The telemark turn produced hip flexion ROM of  $38 \pm 17.1$  for the inside/uphill leg and  $27 \pm 12.0$  for the downhill/outside leg, greater than alpine skiing results. Telemark skiers demonstrated greater hip flexion than alpine skiers when comparing maximum and minimum hip flexion angles for the inside and outside legs. Telemark skiers had knee flexion range from  $88 \pm 6.8$  to  $124 \pm 7.1$  degrees for the uphill knee and  $100 \pm 3.9$  to  $119 \pm 5.2$  for the downhill knee greater than the results from alpine skiing. Differences from previous literature include the following; movements of the hips, knees and ankles near the completion of the sequence, pole plant occurring before the feet become parallel, and the forward to aft foot displacement during the turn.

## CHAPTER I

### INTRODUCTION

The origin of skiing dates back to a time when it was used primarily as a means of transportation, beginning with the earliest migrations of man (Dudley, 1935). Cross country, or Nordic skiing, originated in the Scandinavian countries of Norway and Sweden, and aided travelers across wide-open terrain prior to the 19th century (Tant, Van Gerper-Henn & Lamack, 1992). It was not until the 19th century when the elegance of this sliding and gliding sport developed that individuals became enamored with downhill running or skiing (Dudley, 1935; Flower, 1976; Tant et al., 1992).

Sondre Nordheim, born in 1825 in the town of Telemark, Norway, developed a new concept of downhill descent in the 1850's (Dudley, 1935; Flower, 1976). Referred to as the telemark turn, the innovative style consisted of a graceful arcing movement in which one foot and ski were positioned ahead of the other foot and ski. This unique maneuver was utilized during jumping contests to provide better fore-to-aft stability offsetting the pull of gravity during landings. This technique ultimately became the standard for skiing throughout the world during competitions (Dudley, 1935; Tant et al., 1992). The telemark turn is considered to be one of the prettiest moves in all of free-heel skiing (Freeman, 1974).

Telemark skiing declined with the development of alpine skiing in the early 1900's. Downhill alpine skiing became the focus and telemark skiing was left behind during this period into the 1980's. Telemark skiing has increased in popularity during the last decade. At the present time, the development and

current advances in equipment have given rise to the resurgence of free-heel skiing and ski touring as popular sporting activities. The sales of telemark equipment have increased and more ski manufacturers are venturing into the realm of telemark ski equipment. More skiers are trekking into the backcountry and telemark skiing has gained popularity at lift serviced resorts (Tuggy, 1996).

There has been limited research conducted on telemark skiing. Little information is available to instructors, coaches, and skiers regarding this discipline of skiing. Tuggy (1996) conducted one of the first published studies on telemark skiing. The five-month retrospective study was administered to acquire epidemiological results regarding telemark skiing. Variables in the study included; ski habits, demographics, frequency and types of injuries, and the type of equipment used at the time of injury. Tuggy (1996) reported that telemark skiers attain an overall injury rate of about 10.7 injuries per 1000 skier days, and concluded that the severity of knee injuries among telemark skiers was less than that of their alpine skiing counterparts. Less severe knee injuries sustained while telemark skiing was an impetus to the study.

### **Statement of Purpose**

The primary purposes of this study were:

1. to provide a descriptive kinematic analysis of a telemark turn, and
2. to validate teaching manuals while providing new insight into the mechanics of the telemark turn.

### **Significance**

There is a need to increase the body of knowledge of telemark skiing. Telemark skiing has increased in popularity over the last decade, as the sale of

equipment continues to rise. The advents of technology and the advances made in telemark equipment have provided skiers another method of recreational descent.

At the present, little experimental data has been collected on the sport of telemark skiing. The biomechanics of alpine skiing has been researched extensively to determine forces acting upon the leg (Figueras, Llober, Bulo, Morgenstern, & Merino, 1985; Hull & Mote, 1980; Louie, Kuo, Gutierrez, and Mote, 1984; Louie & Mote, 1985; Mills & Hull, 1991; Quinn & Mote, 1992), forces acting in the knee (Gerritsen, Nachbauer, & van den Bogert, 1996; Maxwell & Hull, 1989; Mote and Kuo, 1989; Read & Herzog, 1992; Webster & Brown, 1996), muscle activation (Aune, Schaff, and Nordsletten, 1995; Hintermeister, O'Connor, Dillman, Suplizio, Lange, & Steadman, 1995; Louie, Kuo, Gutierrez, & Mote, 1984; Louie & Mote, 1985; Tesch, 1995), landing from ski jumps during downhill races (Maxwell & Hull, 1989; Read & Herzog, 1992), skiing mechanics (Lieu, and Mote, 1985; Muller, 1994), and methods to collect 3-D data (Mossner, Kaps, & Nachbauer, 1996; Nachbauer, Kaps, Nigg, Brunner, Lutz, Obkircher, and Mossner, 1996), to mention only a few areas of study. The biomechanical information gathered in this study may be used to improve the PSIA (Professional Ski Instructors of America) telemark manual. The information may also provide insight into potential injury mechanisms involved with telemark skiing.

Telemark skiing enables the body to move like a flexible linked system. When the telemark skier navigates a turn, a greater range of motion occurs at the hip, knee, and ankle than an alpine skier, because the heel of the ski boot is attached to the ski in alpine skiing. The greater range of motion (ROM) may

pose less potential for ligament injuries to the lower extremity, especially the knee.

### **Descriptive Goals**

The descriptive goals of the study were:

1. to determine the angles of the following segments and joints:

hip- flexion/extension, adduction/abduction, and internal/external rotation  
knee- flexion/extension  
ankle- plantar flexion and dorsiflexion  
shoulder- rotation and tilt

2. to determine the relationship and the use of rotary movements during the ski turn between the pelvis and shoulder segments..

### **Delimitations of the Study**

The delimitations of study were:

1. all five adult male subjects were healthy advanced level telemark skiers, and
2. all testing was done on a ski slope down a predetermined course.

### **Limitations of the Study**

The limitations of the study were:

1. the body was treated as a rigid link segment model,
2. only male subjects were analyzed,
3. one trial for each subject was analyzed,
4. the segments were considered to be of uniform density with fixed mass,

5. operator digitizing errors associated with identifying joint centers,
6. no reliability measures were calculated.

### Assumptions

The following assumptions were made for the selection and analysis of the data for this study:

1. the procedure did not affect the subject's movement patterns,
2. the location of the center of mass of each segment was fixed,
3. each segment was as a solid rigid body, and
4. all joints were modeled as frictionless hinge joints.

### Definitions

**Abduction:** Movement away from the vertical axis of the body in the frontal plane.

**Adduction:** Movement toward the vertical axis of the body in the frontal plane, opposite of abduction.

**Center of mass (COM):** That point at the exact center of volume of an object's mass; often called the center of gravity.

**Chord:** A straight line between two points along a curve.

**Crud:** A type of snow condition resulting from previously skied powder conditions.

**Downhill ski:** The ski that is further down the fall line of the hill.

**Down unweighting:** A decrease in the ground reaction force (GRF) below body weight as the COM of the skier moves downward.

**Extension:** When the position between two adjacent segments increases; opposite of flexion.

**Fall line:** The direction of travel down the hill as a result of gravitational forces.

**Flexion:** When the position between two adjacent segments decreases; the opposite of extension.

**Frontal Plane:** A vertical plane separating the body into anterior and posterior halves while in anatomical position.

**Ground Reaction Force:** The contact force applied to the body at the ground  $GRF = m_b a_{COM}$  where  $m_b$  = mass of the body and  $a_{COM}$  = acceleration of the COM.

**Lead leg:** The leg which slides forward during the telemark stance.

**Range of Motion (ROM):** The displacement of two adjacent segments about a joint measured in degrees.

**Sagittal Plane:** A vertical plane passing through the body dividing the body into right and left halves while in anatomical position.

**Shovel:** The widest portion at the front of the ski.

**Side cut:** The distance created by the perpendicular intersection of the chord from the shovel to the tail of the ski.

**Tail:** The rear end point of the ski.

**Telemark turn:** A type of nordic ski turn, characterized by an arcing movement in which one foot and ski are positioned ahead of the other.

**Trailing hip:** The hip, which lags behind the lead hip and follows in the direction of travel.

**Trail leg:** The leg which slides backward during the telemark ski stance, the uphill leg.

**Transition point:** Maximum unweighting during the ski motion. The beginning of the next turn.

**Transverse Plane:** A horizontal plane passing through the body separating the body into top and bottom halves while in anatomical position.

**Unweighting:** The reduction of force below body weight applied by the skier onto the surface. There are two types of unweighting.

**Up unweighting:** A decrease in the GRF below body weight as the COM of the skier move upward.

## CHAPTER II

### REVIEW OF LITERATURE

#### Introduction

The following review of literature provides information about the mechanics of a telemark turn and injuries prevalent among the three disciplines of skiing; alpine, cross-country (nordic), and telemark (nordic downhill). The review begins with the physics of skiing and skiing mechanics. The phases of the telemark ski turn and corresponding body position are then covered, followed by a review of injuries to alpine, cross-country, and telemark skiers.

#### Ski design

Skis are designed to turn while descending a hill because they are wider at the tip and tail than they are in the middle. The fluctuations in dimensions create a side cut to the ski. Modern skis flex longitudinally and torsionally in order for the ski to follow the curvature of a turn. (Howe, 1983). Carved ski turns resemble arcs of a circle and occur when the ski is put on edge (Swinson, 1992). Recent advances in the ski industry have created skis with greater side cuts adapted from snowboards. Parabolic, shaped, or carving skis are terms associated with the new radical side cut skis.

## Physics of skiing

### Basic Physics

#### A. The initiation of motion

There are many physics principles used to evaluate the forces of a skier descending an incline. The physical forces become even more involved as a skier initiates a ski turn. Two basic physics principles are used to get the skis moving downhill upon reaching the summit of a hill. First, the skier must convert gravitational potential energy (PE) into kinetic energy (KE) allowing the mass of the skier to gain a velocity. Second, the skier must create a low coefficient of friction between the ski/snow interface allowing the skis to turn while still maintaining some KE (Swinson, 1992). Figure 2.1 is an example of a skier skiing straight down a hill, but the model is too simple to evaluate the forces involved in a turn sequence.

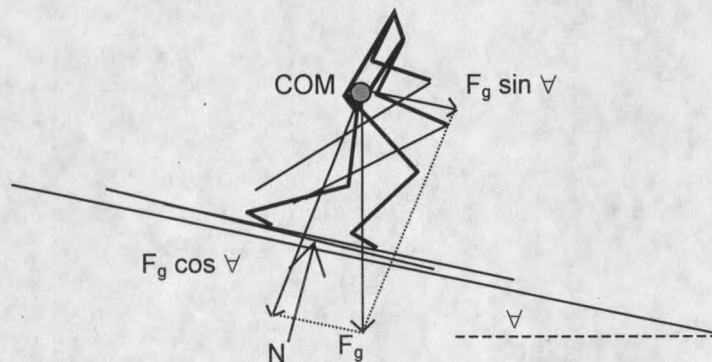

**Figure 2.1. A diagram of the forces acting upon a telemark skier sliding straight down the fall line of the hill (appendix C).**

## **B. Controlling speed**

It is easy for the skier to increase speed when traveling straight down the fall line of a hill, but controlling the speed is more difficult. Side slipping, braking, skidding, and turning are methods used to control speed. Side slipping occurs when the direction of the skis is at an angle from the direction of travel (Howe, 1983). While using the side slipping technique, the coefficient of friction can be altered by manipulating the angle between the ski/snow interface (Swinson, 1992). Movements of the hips, knees, and ankles, termed "angulation" changes the ski/snow interface angle. Greater friction from the uphill edge digging into the slope is caused by a greater angle between the ski edge and the snow surface. Side slipping is the result of a lesser angle allowing the skis to slide sideways (Swinson, 1992). A decreased angle during side slipping causes an increase in ski velocity with a subsequent decrease in control from the reduction of resistive frictional forces, thus increasing the KE of the skier.

## **The Physics of Turning.**

### **A. External forces of a turn**

Turning the skis down the fall line of the hill best regulates speed and provides control. Newton's first law states that a body in motion will continue in a straight line unless acted upon by an outside force. The external forces involved in skiing are: the force of gravity, and the resistive forces of friction and inertia. These external forces act upon the skier as the skier attempts to carve a turn in the snow. Gravity acts vertically downward from the center of mass (COM) propelling the skier along the slope. The frictional force between the ski and snow can be minimized by angulation and unweighting of the skis. Inertial

forces, created by the skis moments of inertia and the body's moment of inertia passing through the vertical axis, provide resistance to turning on snow (Swinson, 1992). Centrifugal forces, acting perpendicular to the gravitational forces, pull the body in a straight-line direction away from the line of the turn (Howe, 1983). Lateral adhesion is a component of gravity directed down the hill and perpendicular to the skis ( $F_{LA} = F_g \sin \alpha \cos \beta$  where  $F_g$  = gravitational force,  $\alpha$  = the slope of the hill, and  $\beta$  = the traverse angle). This force counter acts the centrifugal force in the uphill quadrant thus keeping the skier turning along the arc without side slipping (Howe, 1983). Figure 2.2 shows this relationship.

A ski turn divided into uphill and downhill quadrants has differing net forces in the different quadrants as a result of the interaction of the centrifugal and adhesion components. In the uphill quadrant, the adhesion component acts down the hill in the direction of the fall line while the centrifugal component acts against the turn arc. The greatest amount of force production occurs in the downhill quadrant because both force components act in the direction of the fall line of the hill, pulling the skier away from the turn (Howe, 1983). When the skier is in a position with the skis flat on the snow surface and facing straight down the fall line, the adhesion component becomes zero because there is no component of gravity perpendicular to the skis. It is easier to initiate a ski turn in the uphill quadrant because of less net force acting on the skier.

## **B. Angulation**

Angulation enables the skier to alter the angle between the skis and the slope altering the forces imposed upon the skier. Howe (1983) inferred that angulation is a change in the entire body position of the four linked segment (head, torso, thighs, lower legs) without altering the COM and the gravitational

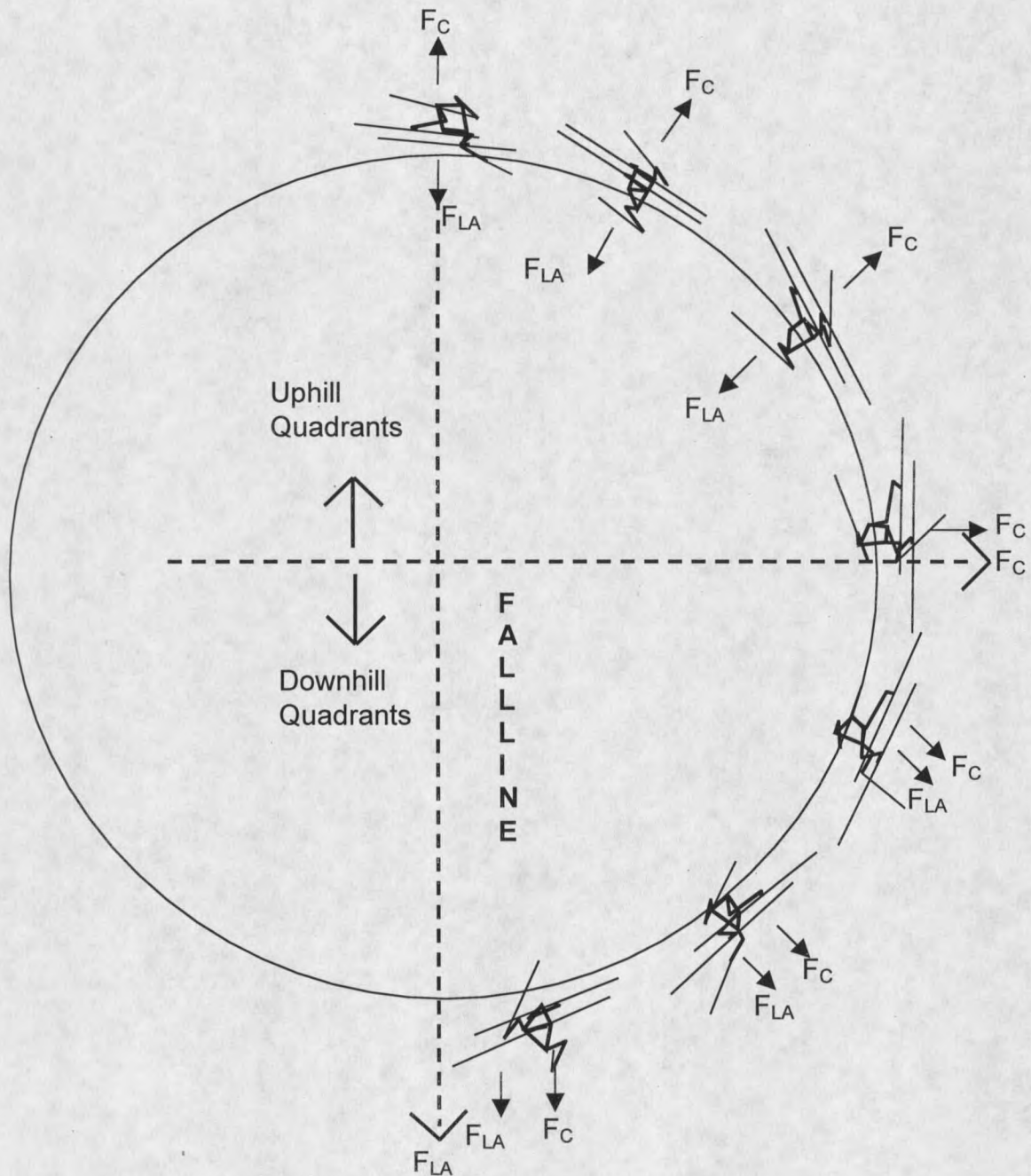

Figure 2.2. The external forces acting on the body during a telemark ski turn. Force of lateral adhesion ( $F_{LA}$ ) and centrifugal force ( $F_c$ ) (Adapted from Howe, 1983).

force. These changes in position affect the alignment of the upper and lower body altering the angle force between the ski edge and the snow. Turning the skis is essentially the transition between carving and skidding. The skier is able to manipulate the fine balance between holding a ski arc and skidding in the direction perpendicular to the direction of the skis by altering the angulation of the hips, knees, and ankles (Howe, 1983). The knees can be shifted sideways to accommodate knee angulation. Movement of the upper body in the opposite direction can create greater angulation. The pelvis is anatomically capable of tilting sideways producing angulation. The hips create a great amount of angulation because as the pelvis shifts to one side the upper body and shoulders move in the opposite direction.

The knee joints with two degrees of freedom have anatomical limitations and were not designed to flex sideways. Flexion and extension occur about the medial/lateral axis with internal rotation of the tibia on the femur occurring during knee flexion (Quinn and Mote, 1992). The knees can not flex laterally when they are in a position of full extension due to the shape of the femoral condyles and the tension of the ligaments. Hence, the knees need to be flexed in order to achieve any degree of knee angulation caused by lateral movements of the tibia on the femur.

The skier can generate skidding from either the shovel or tail of the ski by altering the amount of forward pressure placed upon the ski by the skier. Placing more pressure forward on the skis causes the tail of the ski to skid more than the shovels. Movements of the hip, knee, and ankle can adjust altering the amount of forward pressure. Skiing is the process of constantly adjusting knee and hip angulation. The upper body reacts in the opposite direction of the angulation occurring either naturally or subconsciously (Howe, 1983).

### **C. Unweighting**

Unweighting is the process by which the skier controls normal (N) reaction forces altering the net vertical forces on the body (Swinson, 1992). There are two types of unweighting performed during skiing; up unweighting and down unweighting.

**1. Up unweighting.** In order for upward acceleration of a skier's body to occur, a net upward force is necessary; likewise, a net downward force is required for downward acceleration. Up unweighting occurs as the skier starts in a low body position and pushes upward by extending the hip, knees, and ankles. The skier adds the necessary force to accelerate the body upward against the pull of gravity acting through the legs to the skis (Howe, 1983). The body initially accelerates upwards, as the N force becomes large. As the upward motion slows to a halt, there is a period of downward acceleration and unweighting occurs when the N force is less than body weight known as up unweighting (Swinson, 1992).

**2. Down unweighting.** Down unweighting results as the skier lowers their body from a higher position by flexing the hips, knees and ankles. The skier's body lowers there is negative acceleration which causes the GRF to become less than body weight. This is known as down unweighting. As the downward motion slows to a halt, there is a positive acceleration and the GRF is greater than body weight. Bouncing on a bathroom scale will demonstrate both of these principles. It is critical that the skier is able to utilize and synchronize these movements in order to increase or decrease the total force placed on the snow and skis during a turn sequence (Howe, 1983).

## **D. Technique**

All ski turns use some amount of skidding added to the carved component in order to control the radius of the turn (Howe, 1983). This is essentially what occurs during "real skiing." Truly carved turns are rare due to the large radius produced by the side-cut of the ski. Skidding is used to attain desired speed and control of the turn radius. Inertial forces are reduced and the turning motion starts by generating angular momentum in the upper body and transferring it to the skis prior to unweighting (Swinson, 1992). When the body is unweighted, angular momentum is transferred to the skis and the skis initiate a turn. This is the foundation for most ski techniques.

**1. Down – up - technique.** Exerting less force at the beginning of the turn and more at the end is a desirable sequence producing a style of "down motion - turn - up motion" (Howe, 1983). The skier lowers the COM unweighting the skis at the beginning of the turn. The lowest body position, accompanied by the lowest COM, is attained just before the skier straightens out the turn making the skis carve. Linking turns results in the end up motion from the preceding turn being used to enhance the reduction of force against the snow required for the beginning of the next turn (Howe, 1983). The skier must still lower the COM during the initiation of the subsequent turn in order to angulate and apply additional up unweighting at the critical point.

**2. Up - down technique.** An opposite sequence of "up-motion - turn - down-motion" is not the desirable skiing sequence but is used in certain skiing situations, and was used in the "old days" of ski instruction. Skiers were taught to extend or up unweight at the beginning of a turn. This action causes the force of the snow against the skis to decrease giving the skier the sensation of floating

between jumps while changing direction from one turn to the next. This technique is now employed in situations of deep powder, crud, and thick crust. The technique is also used on extremely steep terrain where it is necessary to execute precise, tight radius turns while controlling the speed of descent. It is desirable to skid at the beginning of the turn and carve during the latter stages. This sequence is accompanied by a forward weight shift of the COM at the beginning of the turn (Howe, 1983). The forward shift causes the skis to skid resulting in a change direction, then the weight shifts rearward utilizing the tail of the ski to finish carving the turn.

**3. Rotation.** Rotary movements are also critical to the ski turn. A skier has the ability to apply a rapid turning torque to their feet and skis by twisting the upper body. A torque of equal and opposite magnitude will cause the feet and skis to twist in the opposite direction. Counter rotary movements of the body are used to adjust the forces during a turn at instants of unweighting and skidding. A counter rotary force is often utilized at the beginning of the turn coinciding with down unweighting causing a skid during the change of direction (Howe, 1983). When a series of turns are linked together, the skiers' shoulders should always be positioned down the fall line. Maintaining a position facing down the fall line the skier is able to increase the twisting force of the skis the instant unweighting occurs by twisting the upper body in the opposite direction. This opposite upper body twisting properly positions the upper body for the next turn, subsequently giving the illusion of little upper body rotation relative the lower body.

### The Telemark Ski Turn

The basic telemark turn consists of various phases of movement coordinated in a smooth flowing manner transferring weight from one ski to the other to initiate the turning of the skis. The telemark ski stance is assumed by sliding one foot in front of the other while relaxing the upper body and maintaining an upright posture. When the lead leg slides forward, the knee of the trail leg flexes and approaches the ski. The toe of the trail foot remains in contact with the ground while the heel rises to complete the position. The lead knee should be flexed with the thigh almost parallel to the ground. A term "double 90's" results because both knees are flexed at approximately 90 degrees (Fig. 2.3). The tip of the trailing ski, or uphill ski, should contact the lead ski a bit ahead of the ski midpoint. Weight should be felt on the entire front foot and the ball of the rear foot and distributed approximately evenly on both skis creating equal edge pressure on both skis at the initiation of the turn.

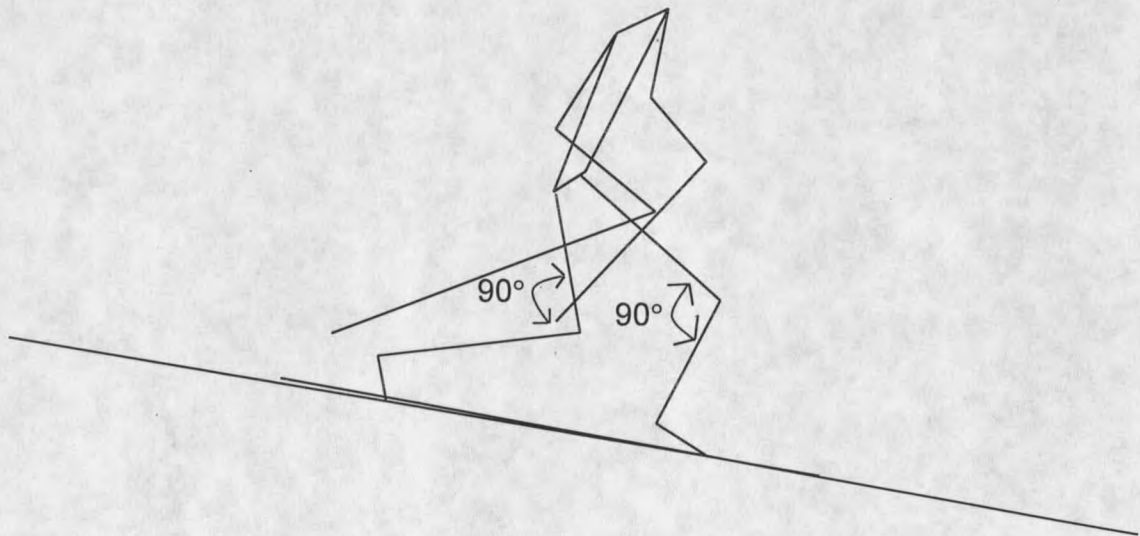
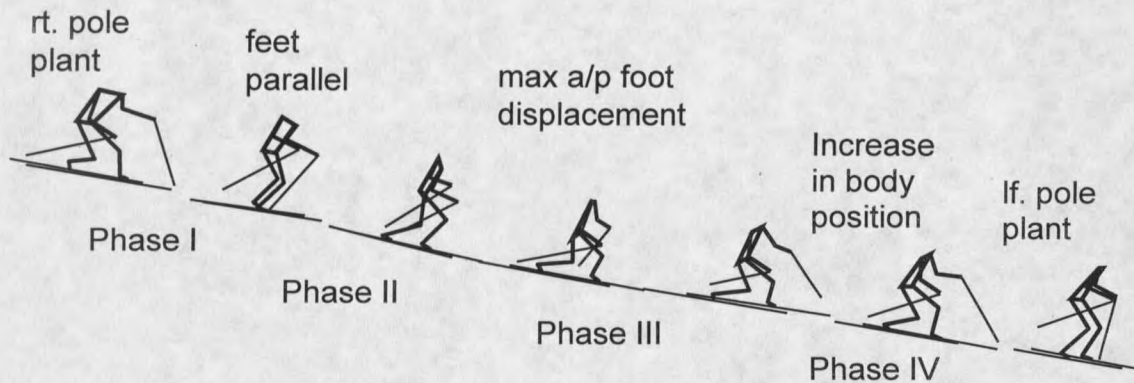

**Figure 2.3. The telemark position, "double 90's".**

An overview of the telemark turn by Tant (1992) divides the turn into four phases known as; Phase I (the preparatory phase), Phase II (the force drop phase); Phase III (the force steering phase), and Phase IV (the recovery phase). A progression of the telemark turn is shown in Figure 2.4. These phases occur as the body gracefully flows through transitions during a telemark turn. The segments of the body move through a range of motion (ROM) during each of these phases, so that each phase consists of a sequence of coordinated movements. The PSIA-NRM Level I Training Manual describes the progression through various levels of telemark competence, going from the basic telemark turn, to the open telemark turn, and finally the dynamic telemark turn. The basic telemark turn is characterized as a wedge telemark turn with the inside ski aligned in a telemark position to the outside ski during the turning motion. This type of turn is typical of beginner telemark skiers. The open telemark turn is characterized as a telemark turn with the body moving in a fluid pattern. A tall body position is attained at the completion of the turn as the body rises from a telemark position, changes lead legs and initiates the succeeding turn. This is an intermediate to an advanced level telemark turn.

### **Phase I**

The preparatory phase of a right hand telemark turn begins after the pole plant when the body elevates and unweights. Just before the initiation of the turn the pole is planted. Prior to pole plant, near the completion of the previous turn, the outside or downhill pole begins to swing due to the movements of the shoulder, elbow, and wrist (PSIA-NRM Level I Training Manual). This occurs simultaneous



**Figure 2.4. Body sequence progression during the telemark turn.**

with the rising motion or extension of the hip and knee joints. As the body moves upward, the skis are unweighted and a tall telemark position results. The poles are extensions of the arms; the basket of the pole traces an arc downhill in the direction of the new turn (Tant et al., 1992). The upper body is controlled and relaxed, moving very little from turn to turn (Tant et al., 1992). These movements create a rhythm for the body to follow during the turn.

The feet are parallel when the body begins to stride into the telemark position. During pole contact, the trail foot (left foot), from the previous left turn, passes the lead foot (right foot) from the previous turn to become the lead foot of the new turn (Tant et al., 1992). Both feet steer in the direction of the new turn (PSIA-NRM Level I Training Manual). The hips lower towards the feet, which accompany the change in lead leg. The new lead hip (left) flexes while the new trail hip (right) extends (Tant et al., 1992). Both knees undergo slight flexion. The left leg strides forward as the left ankle plantar flexes. The right ankle dorsiflexes guiding the rear ski forward, maintaining a parallel relationship with the lead ski.

Due to the forward/aft position of the feet, the telemark position provides good stability forward and back, but lateral stability suffers due to the narrow track along which the skis travel (Tant et al., 1992). The position of the skier's center of mass (COM) along with the relationship between the arms and upper body contributes to maintain lateral balance. The head and upper body should remain stationary (PSIA-NRM Level I Training Manual). The skier's body weight should be distributed evenly between lead and trail skis as the COM lowers.

## **Phase II**

The next phase, force drop, occurs as the body position lowers due to greater flexion in both knees (Tant et al., 1992). As the skier sinks into a lower telemark position, the skis are steered into the fall line of the hill and the COM follows (PSIA-NRM Level I Training Manual). The inside ski is aligned in a telemark position to the outside ski. The lead foot will turn slightly inward while directing the lead ski down the fall line and the body will lean into the turn (Tant et al., 1992). The left knee rotates and points into the direction of the turn. The left hip flexes and rotates medially while the right hip extends with subtle lateral rotation. The pelvis rotates to the right as the body sinks into a deeper telemark position (Tant et al., 1992).

An important relation exists between the upper and lower body. The eyes remain focused downhill with shoulders and hands pointed in the direction of the fall line. The lower body rotates creating "diagonal body position" (Tant et al., 1992). Rotation of the pelvis is vital to the turn. The legs and hips rotate during the turn and the upper body must twist in the opposite direction. The skier will lean into the hill during the turn causing a shift in the COM (Tant et al., 1992).

The upper body must rotate and flex to the left, maintaining balance while driving the trailing hip (the right hip) into the hill.

Lowering the COM causes the body to come closer to the base of support (Tant et al., 1992). When the arms are kept tight to the body while the body lowers, a decrease in rotational inertia about the longitudinal axis accelerates the skier through the turn (Tant et al., 1992). An upright posture with abducted arms will slow the body in the turn.

### **Phase III**

The force steering phase is related to the actual turning motion. For the skier to make a turn, the ski must be put on edge. Leaning into the hill puts the ski on edge. The turning action created by the skis on edge produce centrifugal force, which supports the skier while leaning into the turn. Eversion and dorsiflexion occur in the left foot causing an increase in the frictional component of the ski/snow interface (Tant et al., 1992). As the forces of the turn increase, more pressure must be exerted on the inside edge of the downhill ski (PSIA-NRM Level I Training Manual). This ski becomes the dominant ski in producing the shape of the turn. The shift of the hips causes the COM which was centered over the feet to shift slightly over the inside foot during the turn. When the speed increases more pressure is exerted on the inside edge of the downhill ski accompanied by more inward lean and deeper flexion of the knees and ankles (PSIA-NRM Level I Training Manual, Tant et al., 1992). Increased pressure to the ski edge reduces the amount of skidding in the turn and is responsible for the arcing shape of the turn. Pressure is applied to the skis by eversion and dorsiflexion of the foot (Tant et al., 1992). The pressure must be applied to the skis so they do not slide out. The skis will slide out when the skier leans too far

into the hill. Leaning into the hill must be done by the hips while the upper body remains in the direction of the fall line (Tant et al., 1992).

#### Phase IV

The final recovery phase occurs just prior to pole plant and the initiation of the succeeding turn (Tant et al., 1992). Ski pressure is dominant on the downhill ski during the completion of the turn (PSIA-NRM Level I Training Manual). Once the turn has been completed, the body rises as the legs extend and the dominant pressure shifts from the downhill ski to the uphill ski (PSIA-NRM Level I Training Manual). Plantar flexion occurs in the right ankle and there is a reduction of extension of the right hip. There is extension of the left hip, and right and left knees (Tant et al., 1992). During leg extension, the trail (inside/right) foot begins to move forward thus becoming the lead leg. At this time, pole swing is initiated. The trunk rotates back to the center and the arms begin to move back to the sides (Tant et al., 1992). The skier's body weight will be distributed evenly among both skis. Extension of the hips and knees raises the body causing the center of gravity to rise. The skier will be slowed as more resistance is created therefor enabling the initiation of the next turn (Tant et al., 1992).

The COM moves in the direction of the new turn as the skis are steered onto the new edge (PSIA-NRM Level I Training Manual). The shift in the COM enhances the steering activity of the feet and legs by rolling the skis onto the new edges and guiding the skis into and through the arc of the new turn (PSIA-NRM Level I Training Manual). Guiding the inside ski acts to compliment the movements as well as the arc of the downhill ski. Counter movements and hip angulation facilitate moving the COM into the new turn (PSIA-NRM Level I

Training Manual). A top view of the telemark turn progression is shown in Figure 2.5.

## Injuries

### Alpine Skiing

Alpine skiing injuries have been examined extensively. Relationships between age, sex, ability, and equipment to the number, type and location of ski related injuries have been identified (Campbell, Ettliger, Johnson, & Pope, 1981; Clancy & McConkey, 1985; Ekeland & Holm, 1985; Ekeland, Holtmoen, & Lystad, 1993; Ettliger, Johnson, and Shealy, 1995; Johnson, Ettliger, & Shealy, 1989; Johnson, Pope, & Ettliger, 1976; Figueras, Llober, Bulo, Mortenstern, & Merino, 1985; Lystad, 1985; Renstrom & Johnson, 1989; Shealy, 1985; Young & Crane, 1985).

Reports of injury rates vary between studies because each study has its own methodology; therefore, it is difficult to make exact comparisons between injury rates. Some studies may not register small cuts, lacerations, and contusions, some are based solely on reports from the ski patrol while others are results from doctors (Lystad, 1985). It is believed that many ski injuries go unreported and actual injury rates may be higher than reported (Paletta & Warren, 1994). The following injury rates per 1000 skier days have been noted: 0.91 (Lystad, 1985), 2.18 (Shealy, 1985), 2.5 (Ettliger et al., 1995), 3.5 (Young et al., 1985), 4.2 (Campbell et al., 1979), 5.0 (Johnson et al., 1976), and 9.8 (Clancy et al., 1985). Lystad (1985) revealed lower extremity injuries account for 43% of all injuries and the incidence of knee injuries accounts for 20 to 30% of all ski injuries (Paletta et al., 1994; Figueras et al., 1985).

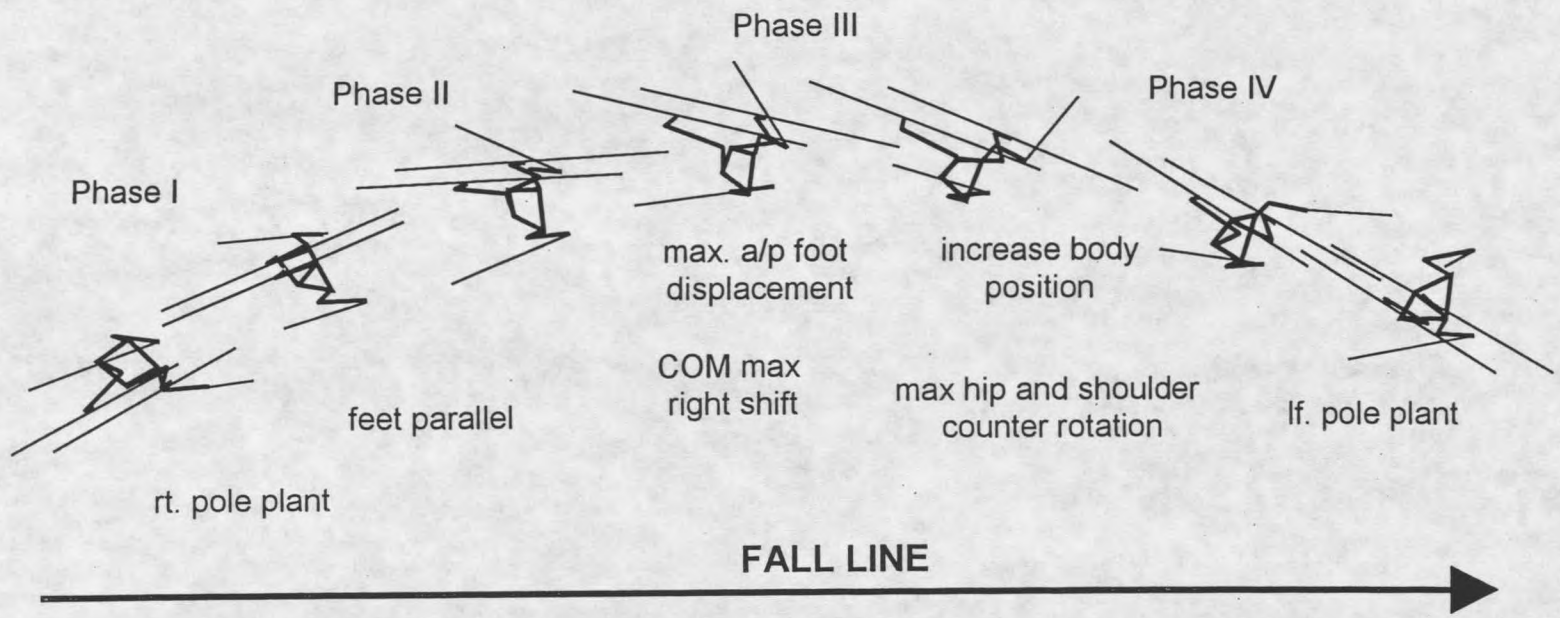

Figure 2.5. Top view of the telemark sequence.

Most injuries to the lower extremity occur because the ski acts as a lever causing the leg to twist or turn. Catching a ski edge can cause the ski to twist creating either external or internal rotational loading at the knee (Paletta et al., 1994). Johnson and his associates (1974) defined the term lower extremity equipment related injuries (LEER), where the injury to the lower extremity was caused by the equipment (Ekeland et al., 1993). Today, many studies in alpine skiing focus on LEER injuries (Ekeland et al., 1993; Ettlinger et al., 1995; Lystad, 1985; Figueras et al., 1985; Johnson et al., 1989; Shealy, 1985). Previous studies have reported the percentage of LEER to be 41% of all injuries, and 90% of the lower extremity injuries (Ekeland et al., 1993). The most common LEER injuries were knee ligament sprains, which are more common in male skiers (Ekeland et al., 1993; Lystad, 1985; & Shealy, 1985). Beginner alpine skiers are at greater risk for injury than are those with higher abilities. Less experienced skiers are injured more often than skiers with 5 or more years of experience and younger skiers are injured more often than older skiers (Ekeland et al., 1993). Studies have shown a decrease in the number of LEER injuries since 1980, but the severity of knee injuries has increased during that period of time (Ekeland et al., 1993; Johnson et al., 1989). Over the last 40 years, there has been downward trend in alpine skiing injuries (Shealy, 1985), a trend most likely related to improvements in ski equipment.

### **Cross-country Skiing**

Epidemiological studies have revealed injury rates in cross-country skiing to range from 0.2 per 1000 skier days (Eriksson & Danniellsson, 1977) to 1.5 per 1000 skier days (Garrick & Requa, 1977). Boyle and colleagues (1985) conducted a study over the 1979-80 and 1980-81 ski seasons and reported an

injury rate of 0.72 injuries per 1000 skier days. These results compare favorably to results established by Sherry (1987) in which 0.49 cross-country skiers were injured per 1000 skier days in Australia during the 1984/1985 ski season. There was a connection between ability level to the number of injuries sustained while cross-country skiing. The risk of cross-country skiing injuries appeared to decrease in skiers with alpine skiing experience (Boyle et al., 1985). It was hypothesized that downhill skiing skills such as edge control, turning, stopping and balance aided in confidence and control in cross-country technique (Renstrom et al., 1989).

Cross-country skiers sustain different types of injuries compared to their alpine counterparts. Upper extremity injuries are more common in cross-country skiing than lower extremity injuries (Renstrom et al., 1989). The number of cross-country injuries has increased over time, most likely due to faster speeds created by technological advancements (Renstrom et al., 1989). The use of new mechanisms, which fix the heel to the ski, and the fact that cross-country bindings do not release may explain the increased number and severity of cross-country injuries (Renstrom et al., 1989).

Lower leg injuries sustained during cross-country skiing are far less frequent than those occurring during alpine skiing. Boyle et al. (1985) and Errickson et al. (1977) reported that only 12% of the injuries to the lower leg were fractures and 60% of the traumatic injuries sustained by the Swedish national team were ankle ligament injuries (Renstrom et al., 1989). Sherry et al., (1987) found the most common traumatic lower extremity injuries were to the knee and ankle, and the mechanism for knee trauma is similar to alpine skiing. Injuries to the medial side of the knee are most common, and if the forces are high, the anterior cruciate ligament (ACL) can also be damaged (Renstrom et al., 1989).

### Telemark Skiing

Information regarding telemark skiing injuries is sparse at best. Ekeland et al. (1993) mentioned 3% of the skiers in his study used telemark equipment. These skiers had a higher injury ratio (3.0) than skiers with standard equipment (1.0). Ekeland (1993) concluded that skiers using telemark equipment were more prone to injury than standard alpine skiers, but mentioned that since the population was so small the figures should be interpreted lightly. Other studies report telemark skiers have injury rates of 4.5 (Pigman et al., 1990) and 10.7 (Tuggy, 1996) injuries per 1000 skier days. The injury rate of 10.7 compares favorably to an alpine skiing rate of 9.8 injuries per 1000 skier days when similar methods were used (Tuggy, 1996). Reports using specific defined populations tend to incur higher injury rates (Ettlinger et al., 1995). It has been shown in studies that as many as 50% of all injuries go unreported to ski patrol and physicians (Clancy et al., 1985, Paletta et al., 1994).

The types of injuries among telemark skiers are becoming similar to alpine injuries. Injuries to the knee, thumb, shoulder and hip are common among telemark skiers. This is due to modern advances in technology and the increased popularity. Tuggy (1996) reported injuries to the knee are the most prevalent comprising 40% of all reported injuries. However, a Swedish study involving 48 injuries from 46 telemark skiers revealed that thumb injuries were most prevalent followed by injuries to the knee (Jorgsholm, Bauer, Ljung, & Lerner, 1991). Beginner and intermediate telemark skiers were injured more than advanced and expert level (Tuggy, 1996).

## CHAPTER III

### METHODOLOGY

#### Introduction

The purpose of this study was to determine the kinematics of a telemark ski turn. A single ski turn was analyzed from initiation to completion using 3-D videography. The methods and procedures that were used to collect and analyze the data are presented in this chapter.

#### Pilot Studies

Several pilot studies were completed prior to the actual data collection. The pilot studies were conducted to determine an appropriate experimental protocol since there has been little biomechanical research of a telemark turn. The initial pilot study was conducted to determine if a viable camera set up could be established to provide accurate images of a skier while descending on snow. A second pilot study was performed to determine an appropriate site on the hill to conduct the study. After some preliminary work videotaping telemark skiers, it was determined that the skier's were discernable on the videotapes and joint centers could be identified for digitizing. The next step was to set a course, videotape the skier making a turn, and determine the distance traveled in order to construct a reference frame.

During the pilot studies, a reference frame was constructed and tested on the ski slope. The reference frame needed to be large enough for a skier to successfully manipulate a turn without compromising technique but small enough to maximize the subject in the field of view. The reference frame also needed to

contrast with the snow background. A reference frame was constructed using bamboo poles with tennis balls attached to them. The poles were plumbed using a level. The distances between poles, distance between tennis balls on each pole, and the height of the poles were measured using a steel tape measure.

From this experiment, it was discovered that the reference frame could not be distinguished from the trees in the background of the course. As a result, it was necessary to place the course amongst a white background. Two cameras were finally incorporated into the pilot study on a slope (the Nastar Course at Bridger Bowl, Bozeman MT) which had the desired pitch and an appropriate background. A ski course was set in the snow and the transitions were noted after watching several trials by one subject. A reference frame was then constructed to include the transitions of the turn and 5 trials were recorded. The video was then digitized and analyzed, and became the criterion for future video taping sessions.

### Subjects

Five, advanced level, male telemark skiers volunteered and gave written informed consent (Appendix A) to all testing procedures in accordance with Montana State University policy. In addition, each subject completed a self-assessment form and ranked their skill level. The type of terrain the individual comfortably and consistently skied determined their ability level. Advanced level skiers were skiers defined as individuals who ski black diamond and double black diamond terrain. Two subjects were PSIA (Professional Ski Instructors of America) certified telemark instructors at Bridger Bowl ski area. All subjects skied frequently and were free from injury with no identifiable physical impairments. Body mass, stature, and age of the subjects along with the length

and type of each subject's skis were obtained from the self-assessment and are presented in Table 3.1 and Table 3.2 respectively.

**Table 3.1. Body mass, stature, and age.**

Subject #	Body Mass (Kg)	Stature (M)	Age (Years)
1	70.5	1.78	20
2	97.7	1.93	30
3	79.6	1.82	27
4	75.0	1.70	26
5	77.3	1.75	42
Mean $\pm$ SD	80.0 $\pm$ 10.4	1.80 $\pm$ .09	29 $\pm$ 8.1

**Table 3.2. Ski length and type of ski used.**

Subject #	Ski length (cm)	Type of ski
1	200	Regular
2	207	Regular
3	190	Parabolic
4	200	Regular
5	190	Parabolic

Subjects wore dark, tight fitting clothing and used their own telemark skiing equipment. Telemark ski equipment consists of a boot that flexes at the metatarsophalangeal joint and a binding, which attaches the boot to the ski only at the toe. The binding allows the heel of the boot to move freely on the ski. All subjects used plastic telemark boots with cable bindings mounted to their skis (Fig. 3.1).

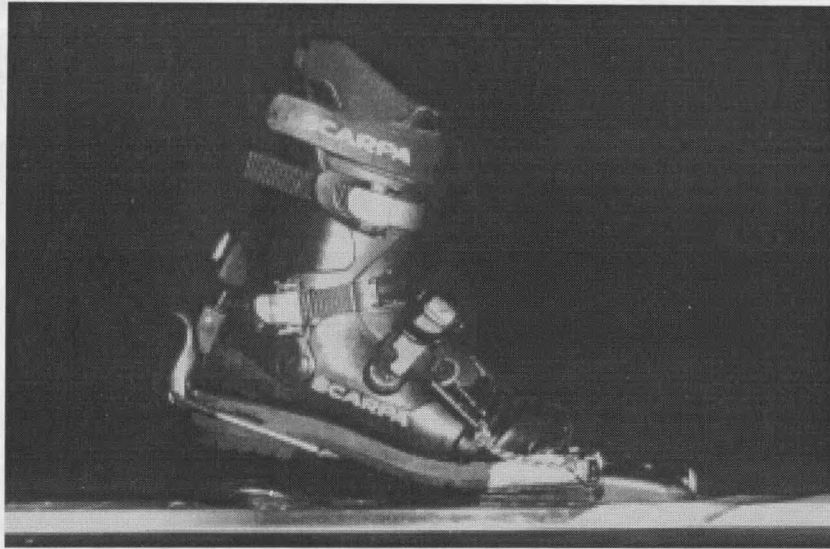

**Figure 3.1. Telemark boot and cable binding attached to ski.**

### **Experimental Protocol**

This section describes the testing protocol used during the study. The instruments, procedures, and methods used during the video taping, data reduction, and data analysis will be discussed. The subjects were approached by the experimenter prior to data collection to determine their willingness to participate in the study. The subjects were selected based on their proficiency as a telemark skier as viewed by the experimenter.

### **Data Collection**

The data collection took place during one testing session April 2, 1997. Prior to the subjects' arrival, the test area was packed down, the course was constructed and the cameras were positioned. The subjects arrived at the course and completed the consent and self-assessment form in compliance with

Montana State University. The testing site was constructed on the Nastar Course at Bridger Bowl ski area in Bozeman, Montana. The slope of the hill was 12 degrees. The night before testing approximately 5 inches of heavy wet snow fell on the ski area. The testing area was packed and side-slipped to create a firm course consisting of heavy packed powder snow conditions. The weather was mostly sunny during data collection and the temperature was approximately 40-50 F degrees. Square pieces of white athletic tape approximately 1.5 inches were placed on the subjects' dark clothing to identify anatomical landmarks used in the digitizing process. The tape was placed on 14 body landmarks to define limb segments (Table 3.3). Figure 3.2 shows a skier with the markers in place. During this time, an explanation of the experiment was given to all subjects. The investigator answered any questions posed by the subjects.

**Table 3.3. Anatomical landmarks for kinematic markers.**

<u>Location</u>	<u>Definition</u>
shoulder	greater tubercle of the humerus
elbow	lateral epicondyle of the humerus
wrist	styloid process
pole basket	pole basket (distal end) of each ski pole
hip	greater trochanter of the femur
knee	lateral femoral condyle of the femur, tibial tuberosity
ankle	lateral malleolus
toe	lateral head of fifth metatarsal
ski tip	tip of each ski
ski tail	tail of each ski



**Figure 3.2. Telemark skier with markers in place.**

Subjects were asked to make telemark turns down a preset course consisting of five break away slalom gates. Each subject completed five trials down the course. Each subject during each trial completed a total of five transitions constituting three complete turn sequences. One right hand turn, the second of three turns, was recorded on video. The turn was defined as progression from one transition point to the next. The transition point was defined as the instance where the feet were parallel. The analyzed motion consisted of the right pole plant prior to initiating a right hand turn to the point where the feet became parallel after the left pole plant. The radius of the turn was calculated to be approximately 9.2 meters with an average velocity over all subjects of 6.3 m/sec. Subjects were allowed practice runs to familiarize themselves with the course and snow conditions. Each trial consisted of the five

subjects consecutively skiing through the course. All subjects would then hike back up the hill to the start point and commence with the next trial.

### Instrumentation

Two Panasonic S-VHS video cameras (model AG-450, operating at 60 fields per second, placed approximately 80 degrees apart from one another) were fixed and mounted on tripods. The angle between the cameras was estimated by aligning the cameras with the ends of a goniometer and reading the angle. The cameras were placed between 10 and 12 meters from the reference frame. The zoom on the cameras was adjusted to maximize the reference frame in the viewfinder (Fig. 3.3, Fig 3.4).

The reference frame consisted of four bamboo poles creating a reference box. Control points consisted of black painted tennis balls attached to each pole. The poles were approximately 2.5 meters long and had either two or three balls attached to it depending upon their position.

The two poles at the initiation point of the turn had two balls attached to each pole, while three balls were attached to the downhill poles positioned beyond the next transition point. The poles at the initiation of the turn had tennis balls located at both the top and bottom of the pole. The lower points were located near the snow level and were aligned using a string level. This ensured that the two lower control points were in the same plane. The three control points on the downhill poles were located at the top of the pole, level with the bottom control point from the uphill pole, and at the bottom of the pole near the snow (Fig. 3.5). The tennis balls were cut with a knife so they would slide onto the pole and could be oriented. A string level was used to provide a linear

method of aligning the control points. The lower control points of the upper poles and the middle control points of the lower poles were all co-planar. The bottom control points of the lower poles were also aligned in the same plane.

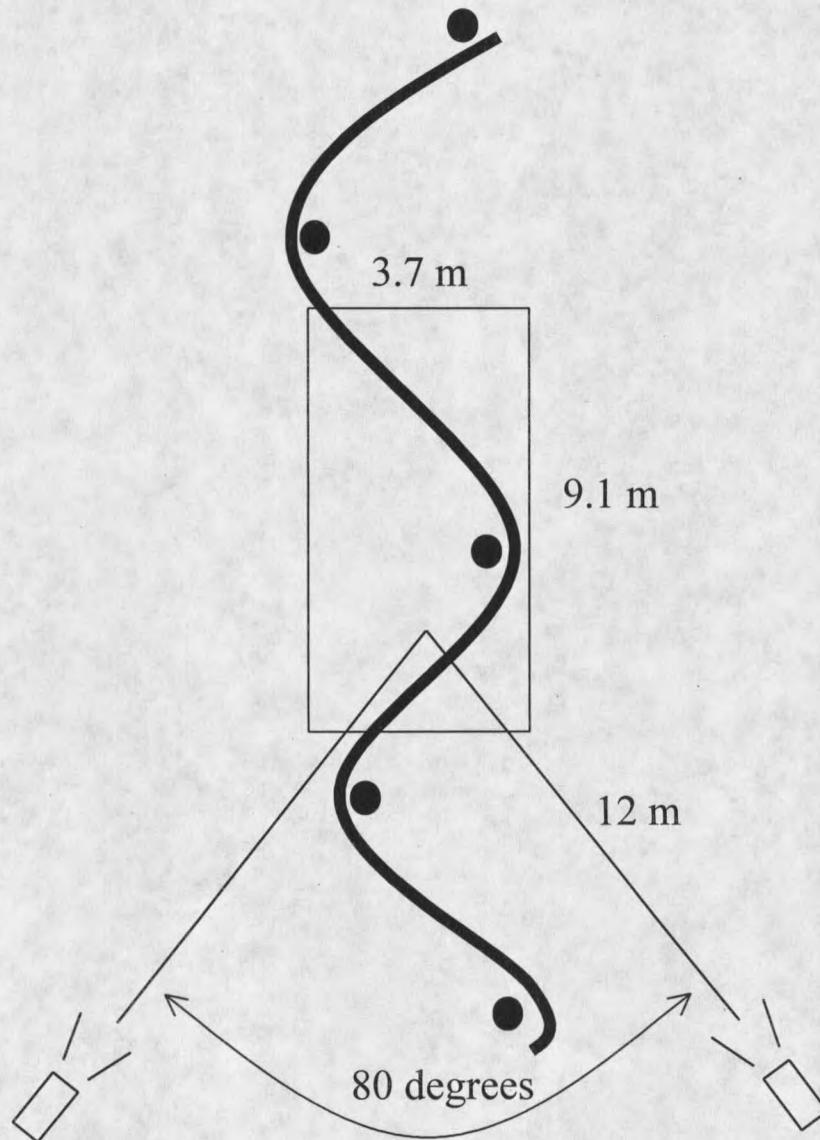
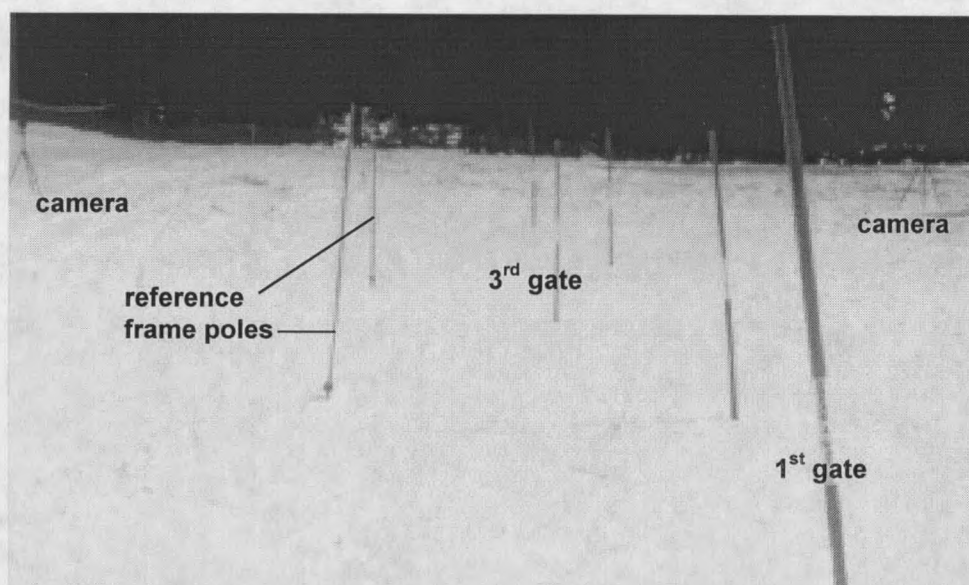

Figure 3.3. The ski course and reference frame viewed from above.



**Figure 3.4. Picture of the ski course looking downhill.**

Distances between control points on each pole were measured to the nearest centimeter (cm) using a steel tape measure and recorded. All reference poles were plumb after being placed into the snow. The poles were located 3.66 m apart in the frontal plane and 9.14 m in the sagittal plane. The distance down the slope was measured to be 9.31 m. The slope of the hill was calculated from the distances between poles after the reference frame had been constructed. Control points were distributed within the field of view of the cameras and did not interfere with the skier.

### **Data Reduction**

The video was viewed using a Panasonic Video Cassette Recorder (model AG-7150) attached to the Ariel Performance Analysis System (APAS). Trials were evaluated using a set of parameters consisting of: technique, smoothness, visual aspects, and motion within the confines of the reference

frame. Both views needed to satisfy the parameters in order to qualify as a potential trial for examination. The best trial as deemed by the investigator was chosen for the kinematic analysis. The contact of the subjects right ski poles with the snow was used as the zero point in order to synchronize both the right and left video images. The data were digitized at 30 frames/sec. All subjects completed the turn sequence between 1.3 and 1.6 seconds. Each digitized image included a fixed point, anatomical landmarks representing limb segments, and points on the tip and tail of each ski. The two 2-D images were transformed to create a 3-D model using the direct linear transformation (DLT) technique (Mossner, Kaps, and Nachbauer, 1996).

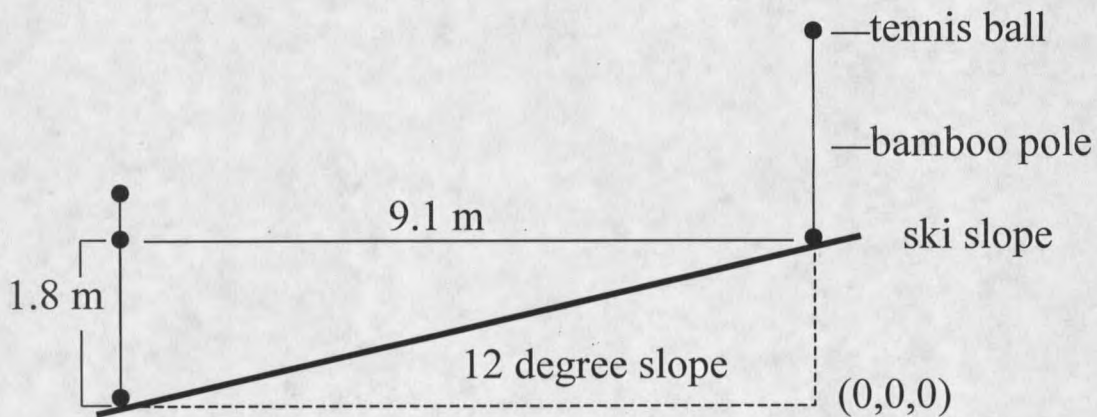

**Figure 3.5. Sagittal view of the control frame and bamboo poles.**

The number of control points used in the DLT process affects the accuracy of the DLT (Chen, Armstrong, and Raftopoulos, 1994; Hinrichs and McLean, 1995; Mossner et al., 1996). At least six control points must be visible in each image, any three may not be collinear and any four not coplanar in order

to produce accurate results (Mossner et al., 1996). Using more than 6 points increases the accuracy of the DLT, but increasing the number of control points beyond 16 points provides limited improvement in the DLT (Chen et al., 1994). Hinrichs and McLean (1995) reported increases in DLT accuracy while increasing the number of control points up to 60. Improvements may continue using more control points because the points become more evenly distributed across the control frame. The accuracy of the DLT for this study was 4.5 cm, 1.0 cm, and 1.2 cm in the x, y, and z directions respectively. After transformation, the 3-D coordinates were smoothed using a cubic spline filtering technique (Appendix B).

### **Data Analysis**

Joint angles, segment angles, and position data were calculated from a link-segment model comprised of 13 rigid segments representing the skier. These kinematic variables were calculated from the 3-D analysis of the body using the APAS system software. In order to calculate the kinematic variables in an anatomical reference frame, a coordinate system was created within the skier's trunk. The origin was the center of the two hips, the spine was used as the y-axis, and a line extending forward from the midpoint of the hips created the x-axis. This configuration allowed the movement of the extremities to be analyzed in a hip centered coordinate system. The original 3-D coordinates were transformed to the new (local) coordinate system and then analyzed with the APAS system to determine foot displacement, hip adduction/abduction, hip flexion/extension, shoulder segment rotation and tilt, trunk flexion, and position changes of the COM. Figure 3.6 represents the two coordinate systems.

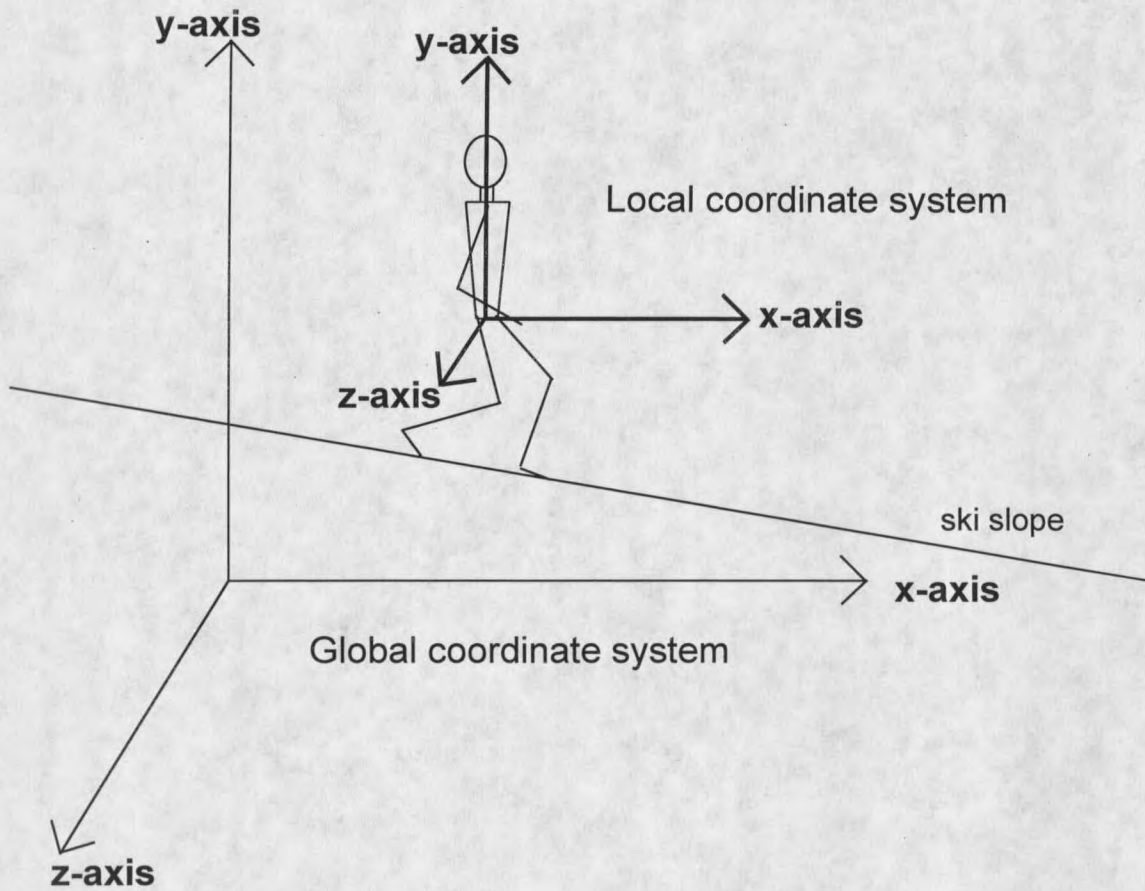

**Figure 3.6. The two coordinate systems.**

The distance between the feet during the turn was calculated in both the x (Fig. 3.7) and z (Fig. 3.8) directions of the local coordinate system. The distance along the x-axis corresponds to anterior-posterior distance the subjects feet travel during the telemark the turn. The medial-lateral separation between the two feet corresponds to the distance along the z-axis. The location of the COM in all three planes was calculated in both the global and local coordinate systems.

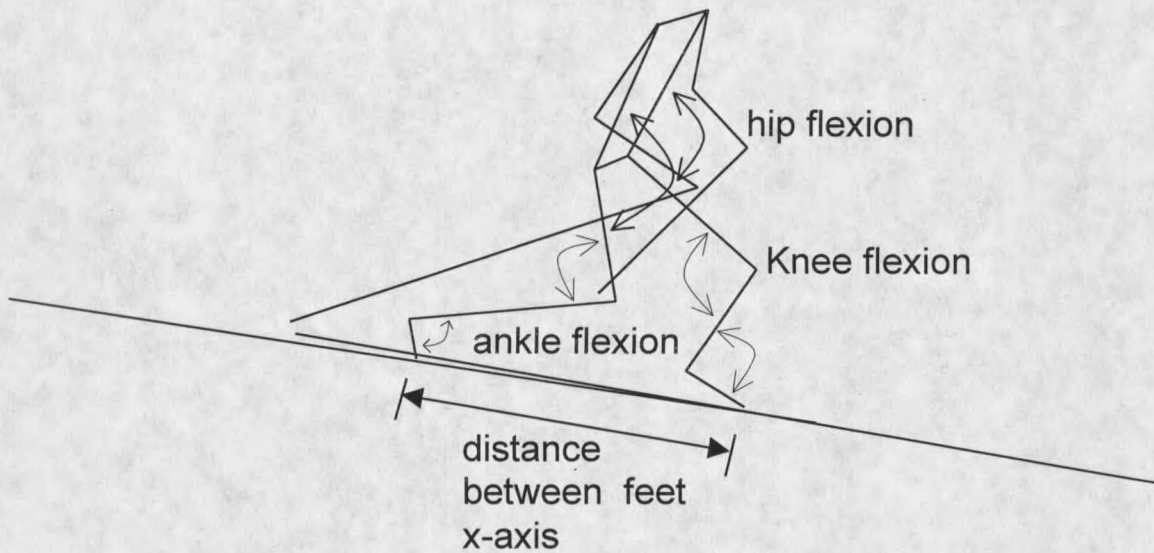
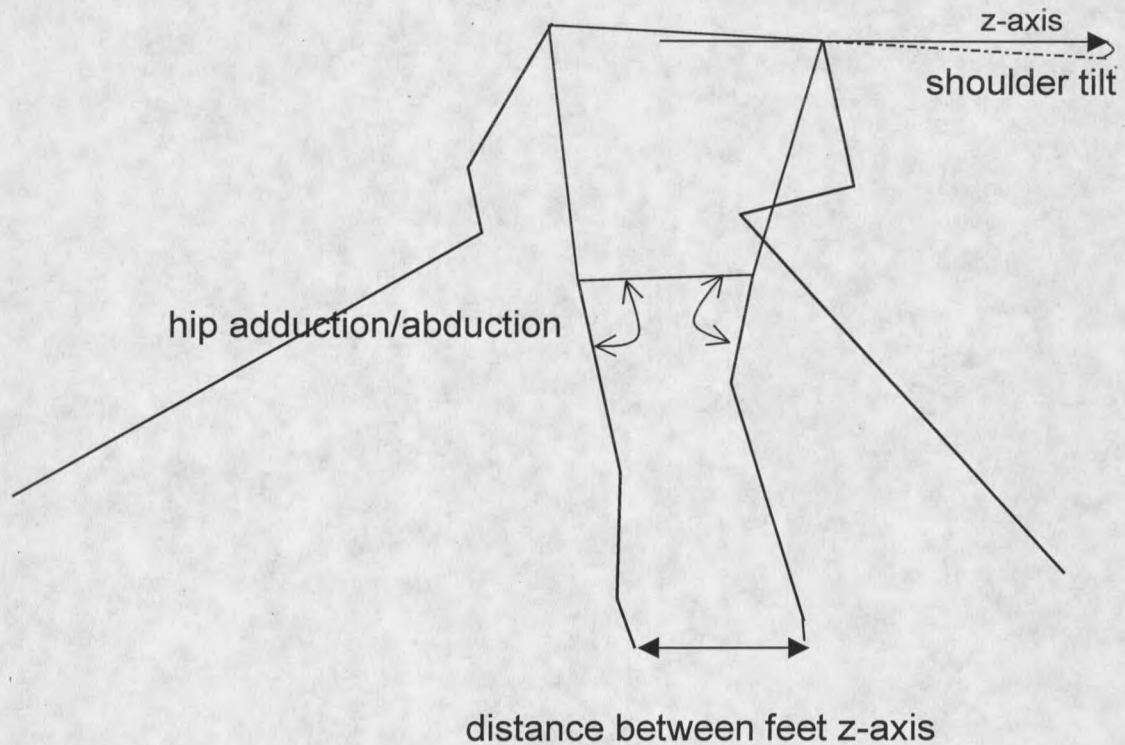

**Figure 3.7. Sagittal plane variables.**

The pelvis and shoulder motions were attained from the transformed 3-D data of the local coordinate system. Abduction and adduction of both legs at the hip joint were calculated as the internal angles of the thigh and hip along the frontal axis (Fig. 3.8). A neutral position of zero degrees indicated no movement away from the mid-line of the body, thus neither adduction nor abduction. The interior trunk thigh angle was used to determine the amount of hip flexion (Fig. 3.7).

Internal and external lower limb rotation was determined by calculating the angle of the skis to the anterior/posterior axis of the skier in the traverse plane of the local coordinate system. The angles created by the skis were indicative of the rotation of the entire lower limb to the pelvis segment (Fig. 3.9). A negative angle exhibited a lower limb rotation to the right of the anterior/posterior axis of

the pelvis segment while a positive angle represented a rotation to the left of the anterior/posterior axis of the pelvis segment.



**Figure 3.8. Three frontal plane variables.**

Shoulder tilt was calculated as the angle between the line connecting the two shoulder joints and the z-axis using the local coordinate system. The position of the shoulder segment and their relationship to the turn was viewed from the frontal plane. A zero angle indicated a position parallel to the pelvis segment. A positive angle represented a tilt to the right and a negative angle represented a tilt towards the left as the skier traveled through the course (Fig. 3.8). Shoulder rotation was viewed from the longitudinal axis of the skier and a zero angle indicated that the shoulders are aligned with the hips. A negative

angle indicated a right rotation of the shoulders and a positive angle was characteristic of rotation to the left during the right ski turn (Fig. 3.9).

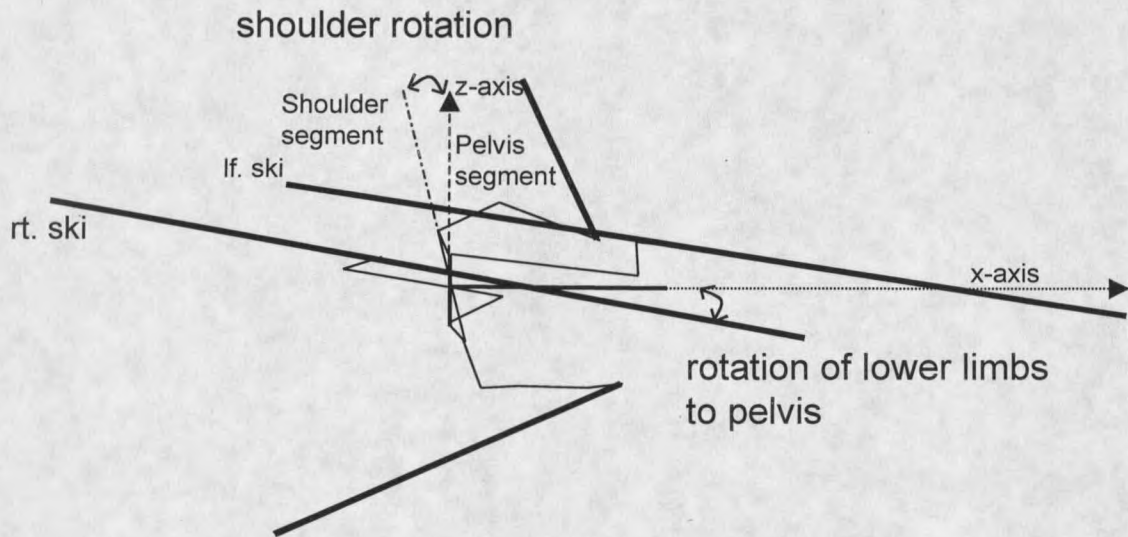
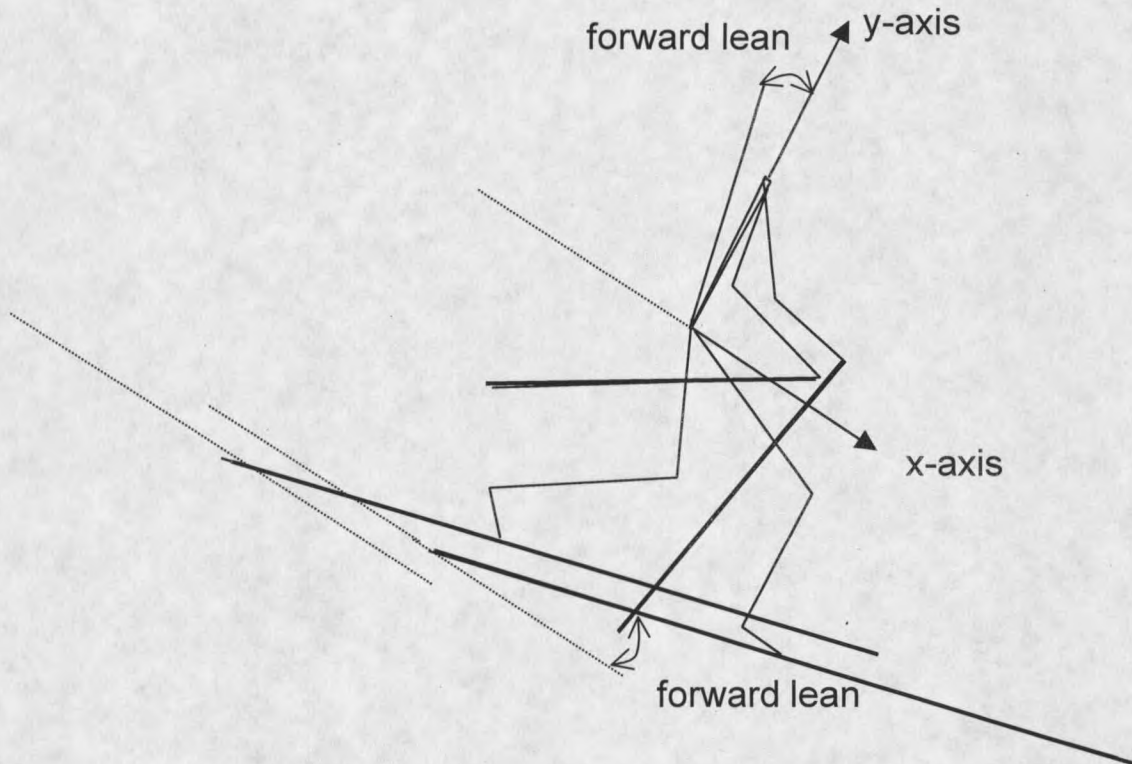

**Figure 3.9. Transverse plane diagram of leg and shoulder rotation.**

The forward lean of the skier was determined by averaging the angle of both skis to the anterior/posterior axis of the skier in the local coordinate system. Since the trunk was ridged and the coordinated system fixed to the trunk of the skier, the ski angle in the sagittal plane represents the trunk angle in the global coordinate system (Fig. 3.10). An angle of zero represented no forward flexion of the skiers' trunk during the turn sequence.

Ankle and knee displacements were calculated by using an included angle for both using the global axis system (Fig. 3.7). The knee and ankle data along with the amount of hip rotation were determined from the original 3-D data using the global coordinate system. The rotation of the pelvis was determined from the longitudinal axis along the z-axis in the transverse plane. A positive angle

indicated rotation of the pelvis to the right while a negative angle was rotation to the left (Fig. 3.11).

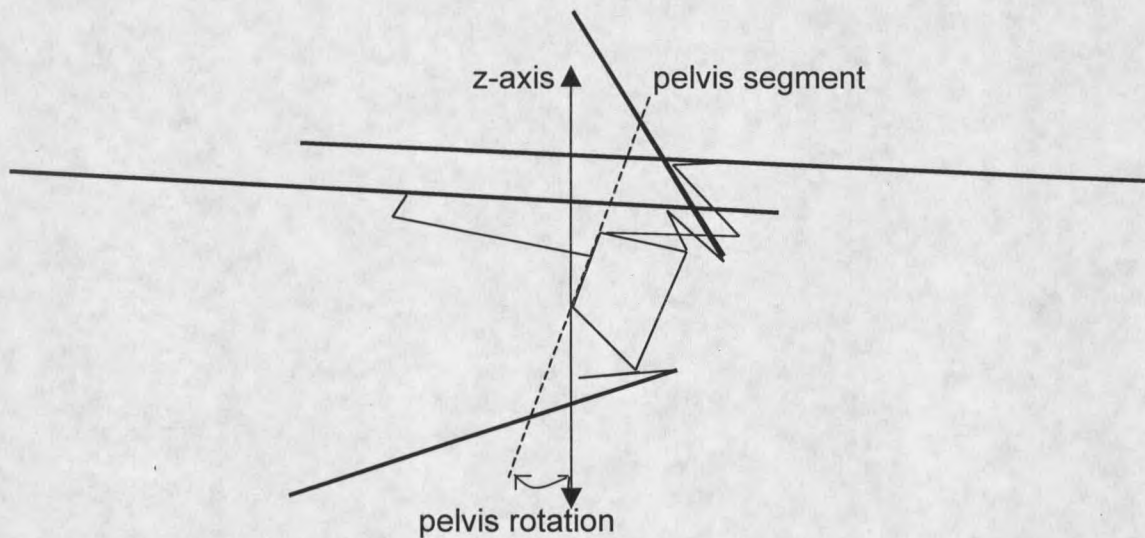

**Figure 3.10.** Diagram representing the amount of forward lean during the turn.

### Descriptive Results

Descriptive characteristics and summary statistics were calculated for the kinematic data. The descriptive characteristics consisted of the joint range of motion (ROM), and the time progression of the turn. Summary statistics for the five subjects were derived from the previously described movements of the body during a telemark turn. The summary statistics consisted of the average

maximum ( $\pm$ sd) values of all subjects, the average minimum ( $\pm$ sd) values for all subjects and the average range ( $\pm$ sd) over all subjects for each kinematic parameter. Sequence information coordinated with time intervals during the progression of the turn was used for descriptive characteristics. There was no statistical testing of a hypothesis for this study.



**Figure 3.11. Traverse plane hip rotation.**

### Summary

Five advanced level, male telemark skiers were chosen to participate in this study. The subjects were videotaped making a right hand telemark turn down a 12-degree ski slope. All data was collected during one session. Joint angles, segment angles, and position information was used to describe the telemark motion, while confirming present instructional material.

## CHAPTER IV

### RESULTS

#### Introduction

All subjects showed very similar characteristics and kinematic patterns. Average sequential characteristics of a right hand telemark ski turn are described starting with right pole plant (zero percent) and ending with feet parallel after left pole plant, initiating a turn to the left (100 percent). A sequence of events was created from all five subjects by determining which frame specific events occurred. These points were assigned a percentage of the individual sequence by dividing the specific point of each subject into the overall length of each subject's sequence. The individual percentages were averaged and a group average was attained from all subjects.

#### Sequence

Figure 4.1 shows the sequence of events involved in the telemark turn based on the averages of the five advanced level skiers in the study. Right pole plant, or zero percent, is the initiation of the turn sequence. At this point in time, maximum right hip abduction occurred with maximum external rotation of the right leg, and the feet are positioned the furthest apart medial/lateral averaging 26.8 cm. At  $10\% \pm 2.5\%$  into the turn, the hips are flexed 127 degrees. At  $12\% \pm 8.1\%$  into the turn, maximum shoulder tilt of  $13 \pm 5.6$  degrees to the right occurs as the right shoulder drops. At  $14\% \pm 5.9\%$  into the sequence, the shoulders are maximally rotated to the right  $-24 \pm 9.5$  degrees. At  $19.4\% \pm 4.5\%$  into the turn, the feet become parallel. Foot displacement in the anterior/posterior

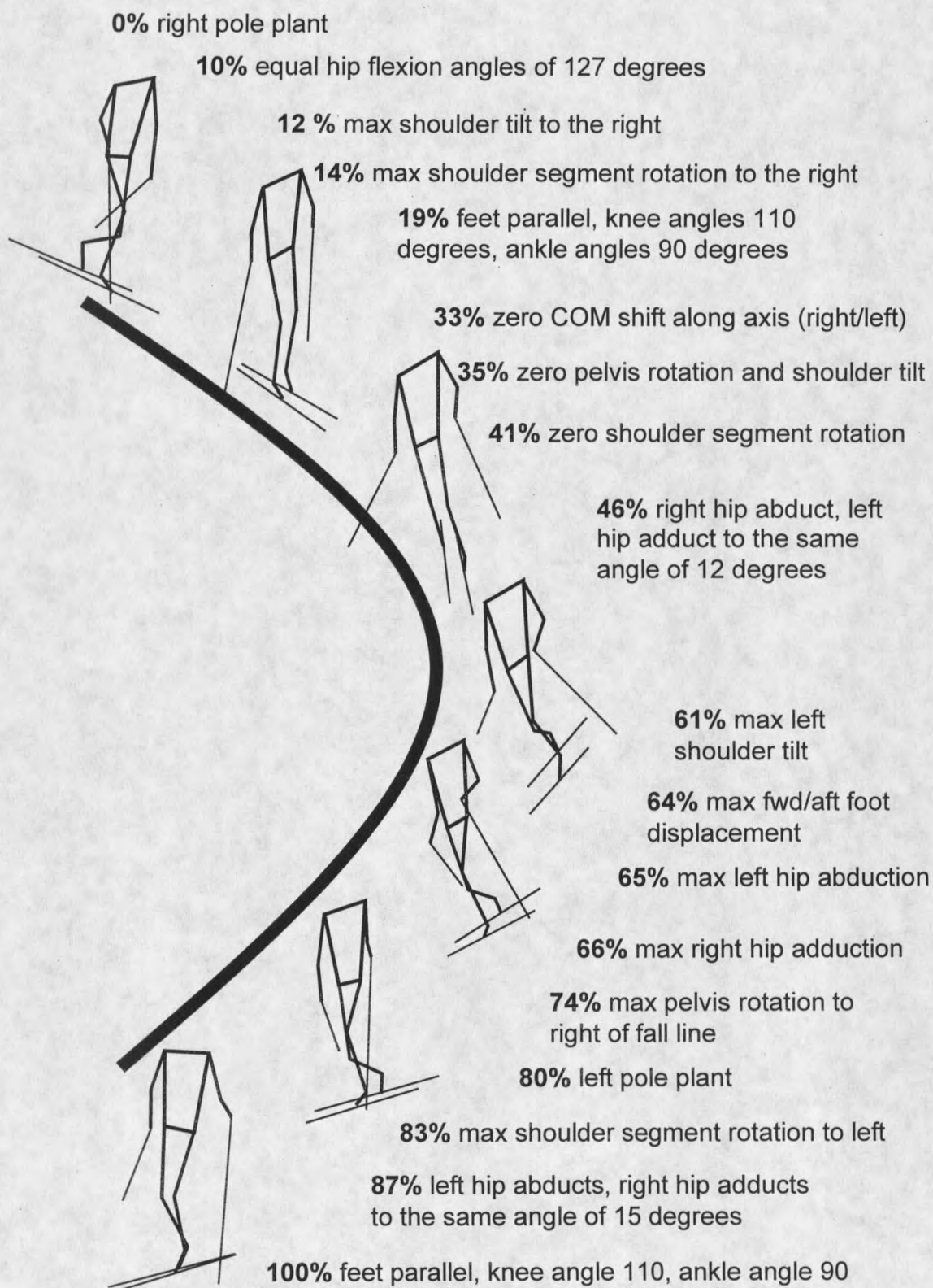

Figure 4.1. The telemark turn sequence.

direction reached minimum at the point where the feet were parallel. All subjects attained a parallel foot position between 13 and 24% through the turn. At 35% into turn sequence, the pelvis  $\pm 5.4\%$  is at zero rotation, the legs are in a neutral position and the shoulder tilt  $\pm 11.4\%$  is zero as the skier faces down the fall line. At 41%  $\pm 10.4\%$  into the turn, zero shoulder segment rotation is attained. At 46%  $\pm 8.7\%$  into the turn, the legs are aligned the same as both hips are adducted 12 degrees. At 61%  $\pm 12.7\%$  into the turn, maximum shoulder tilt occurs to the left with an average angle of  $-9 \pm 5.2$  degrees. At 64%  $\pm 8.6\%$  into the turn, average maximum foot displacement occurs. The average maximum displacement ranged from 53.0 to 87.9 cm. At 65%  $\pm 3.7\%$  into the turn, the left hip reaches maximum average abduction of  $15.2 \pm 21.8$  degrees, and at 66%  $\pm 11.8\%$  into the turn, the right hip attains maximum adduction of  $-23 \pm 5.2$  average degrees. At 74%  $\pm 5.1\%$  into the turn, there is average maximum pelvis rotation of  $-36 \pm 7.1$  degrees to the right of the fall line. At 80%  $\pm 4.6\%$  into the turn, the left pole plant occurs in the sequence. At 83%  $\pm 13.2\%$  into the turn, there is maximum shoulder rotation of  $16 \pm 7.7$  average degrees to the left. At 87%  $\pm 8.3\%$  into the turn, both legs align again adducted 15 degrees. At 88%  $\pm 8.9\%$  into the turn, the hips are again flexed 127 degrees. The shoulders attain zero tilt again at 95%  $\pm 2.6\%$  into the turn, with the feet becoming parallel at 100%  $\pm 5.7\%$  into the turn sequence.

### Lower Extremity

At right pole plant, the right foot was slightly ahead of the left foot. The left foot moves forward continuing past the right foot to maximum anterior/posterior displacement occurring approximately at the apex of the turn. The feet were furthest apart medial/lateral at pole plant (average 26.8 cm) moving closer

together through the turn sequence reaching a minimum (average 10.3 cm) at  $88\% \pm 6.5\%$  into the turn, then moving further apart before the initiation of the next turn. Foot displacement in the anterior/posterior direction reached minimum at the point where the feet were parallel.

The right and left ankle flexion angles had similar patterns between subjects (Table 4.1). The right ankle went through a sequence of dorsiflexion, plantar flexion, and dorsiflexion with an average range of motion (ROM) of  $37 \pm 15.8$  degrees. The left ankle went through a sequence of plantar-flexion, dorsiflexion with an average ROM of  $19 \pm 4.7$  degrees (Fig. 4.2). Shortly after pole plant, when the feet become parallel as the right foot slides forward, both ankle and knee angles became nearly identical. At this point,  $19\% \pm 4.5\%$  into the sequence, an average ankle angle of 90 degrees was accompanied by a 110 degrees average knee angle. Maximum up unweighting occurs at this time and again at the completion of the sequence. Extension of the hips and knees raise the body causing the center of gravity to rise. When the hips and knees extend there is an increase in force between the ski/snow interface which accelerates the body mass upward and away from the slope (Howe, 1983). Unweighting is used to enhance the reduction of force against the snow required for the beginning of a turn (Howe, 1983). The position and acceleration plots of the COM (Fig 4.3) explain this principal by showing the relationship between force and acceleration ( $F=ma$ , where  $f$ =force,  $m$ =mass,  $a$ =acceleration).

Table 4.1 Ankle flexion angles.

Subject	RIGHT ANKLE (degrees)			LEFT ANKLE (degrees)		
	min	max	ROM	min	max	ROM
1	70	111	41	89	105	16
2	74	134	60	91	125	34
3	75	92	17	81	110	29
4	71	107	36	91	103	12
5	62	92	30	59	112	53
Ave $\pm$ sd	70 $\pm$ 5.1	107 $\pm$ 17.3	37 $\pm$ 15.8	82 $\pm$ 13.6	111 $\pm$ 8.6	29 $\pm$ 16.3

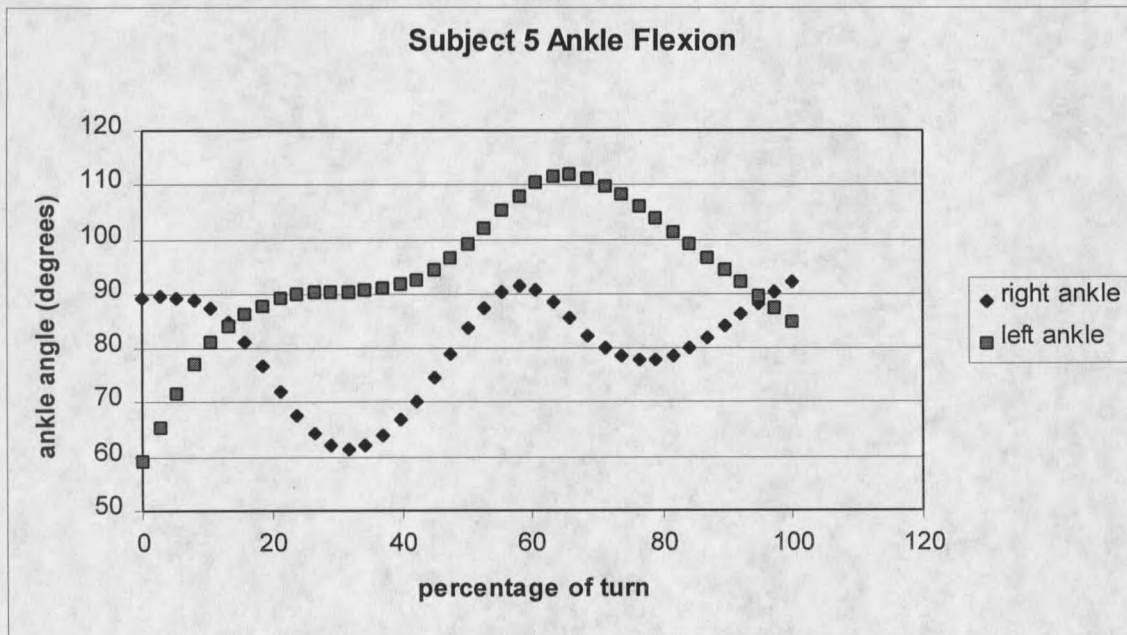
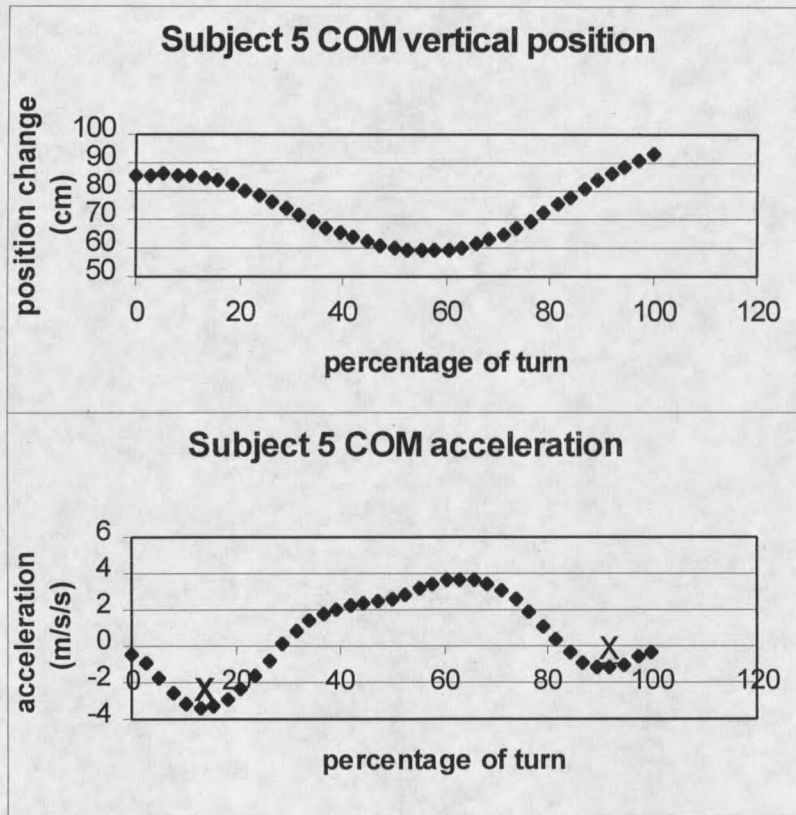

Figure 4.2. Ankle ROM during the telemark turn.



X= points of unweighting.

**Figure 4.3. Position and acceleration of the COM.**

The right and left knee ROM were similar among subjects (Table 4.2). The average knee flexion ROM was  $36 \pm 7.3$  degrees for the right knee and  $19 \pm 4.7$  degrees for the left knee. The left knee flexion angle was 17 degrees less than the right knee flexion angle because during a right hand telemark turn the inside knee (right knee) has to flex more as the body lowers into a telemark position. The right knee exhibited a pattern of flexion and extension during the turn sequence with slight flexion and extension occurring within the overall pattern. The left knee followed a pattern of extension, flexion, extension, and flexion (Fig. 4.4). All subjects had similar characteristics.

Table 4.2 Knee flexion angles.

Subject	RIGHT KNEE FLEXION (degrees)			LEFT KNEE FLEXION (degrees)		
	min	max	ROM	min	max	ROM
1	92	135	43	99	117	18
2	94	127	33	103	123	20
3	86	119	33	104	124	20
4	91	118	27	94	119	25
5	77	121	44	99	111	12
Ave $\pm$ sd	88 $\pm$ 6.8	124 $\pm$ 7.1	36 $\pm$ 7.3	100 $\pm$ 3.9	119 $\pm$ 5.2	19 $\pm$ 4.7

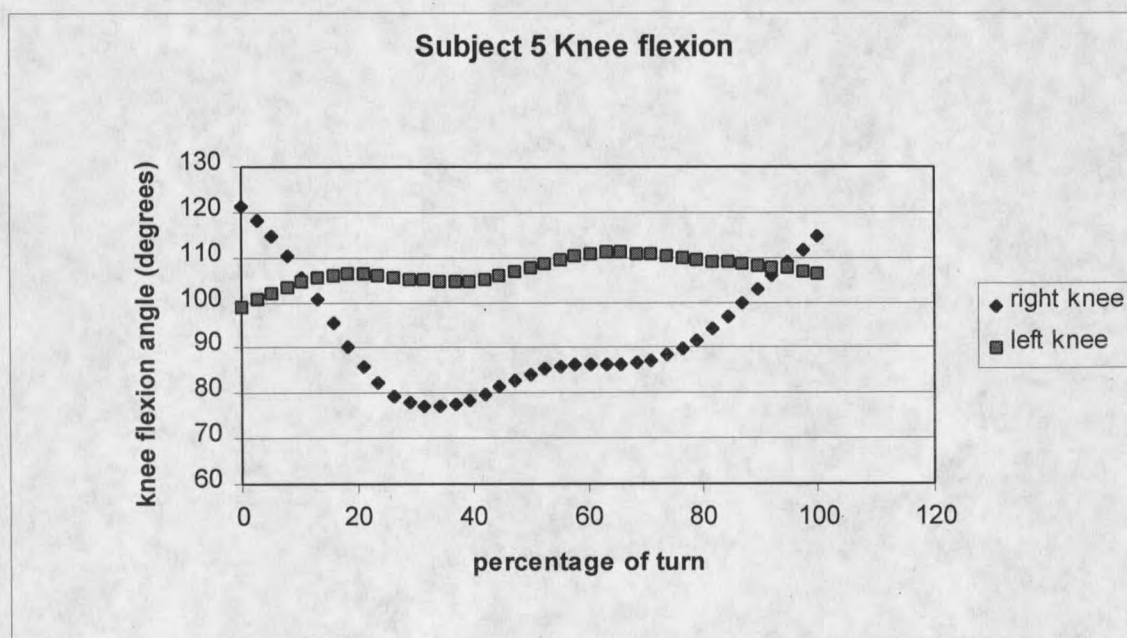

Figure 4.4. Knee ROM during the telemark turn.

## Hips

All subjects displayed similar hip flexion angles (Table 4.3). During the turn sequence, the right hip underwent extension from the initiation of the turn and attained maximum extension near the apex of the turn. This was followed by hip flexion as the body rises out of the turn. The right hip had an average ROM of  $38 \pm 17.1$  degrees. The left hip was in a position of maximum left hip extension at the initiation of the sequence as the body was rising from the previous turn. The left hip underwent flexion and then extended after maximum flexion. The left hip had an average ROM of  $27 \pm 12.0$  degrees. After right pole plant, the right hip extended as the left hip flexed. This movement was coordinated with the movement of the left foot sliding forward in front of the right foot in order to initiate the next turn. Hip flexion angles of both the right and left hip became the same shortly after pole plant with an average hip flexion angle of 127 degrees occurring at  $10\% \pm 2.5\%$  and then again at  $88\% \pm 8.9\%$  into the turn sequence (Fig. 4.5). At the point of maximum forward/aft foot displacement, the right average hip flexion angle was 145 degrees, greater than the average hip flexion angle of 117 degrees for the left hip.

**Table 4.3 Hip flexion angles.**

Subject	RIGHT HIP FLEXION (degrees)			LEFT HIP FLEXION (degrees)		
	min	max	ROM	min	max	ROM
1	117	145	28	108	132	24
2	100	159	59	103	142	39
3	115	141	26	114	153	39
4	107	162	55	119	141	22
5	116	140	24	119	130	11
Ave $\pm$ sd	111 $\pm$ 7.3	149 $\pm$ 10.4	38 $\pm$ 17.1	113 $\pm$ 7.0	140 $\pm$ 9.2	27 $\pm$ 12.0

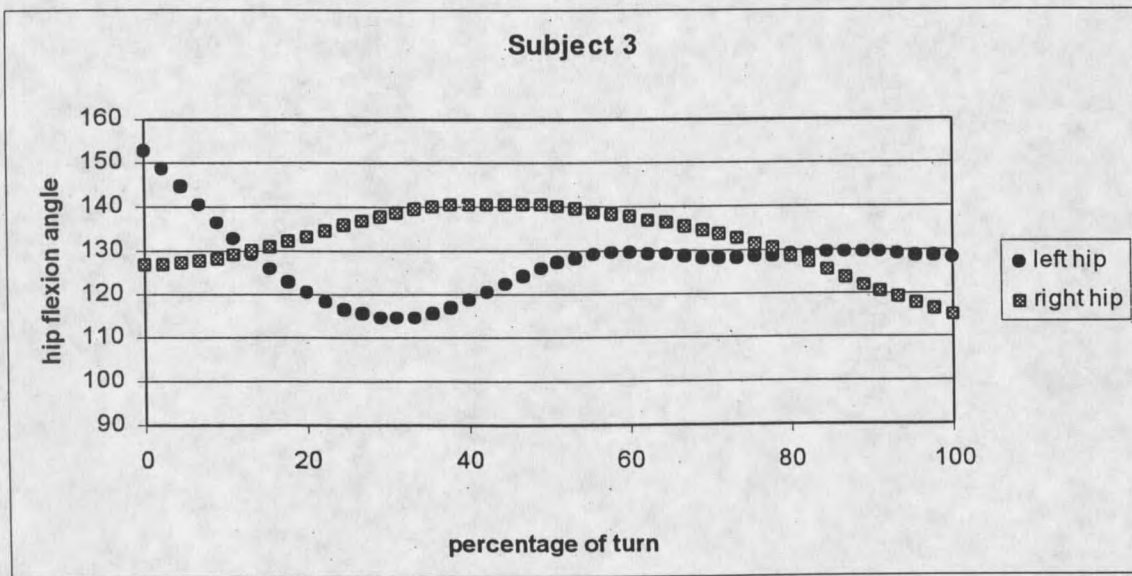

**Figure 4.5. Hip flexion ROM during the telemark turn.**

Hip adduction and abduction occur in both hips during the telemark turn. Right hip average ROM was  $52 \pm 10.9$  degrees while left hip ROM was  $46.8 \pm 30.5$  degrees (Table 4.4). The right hip was at maximum abduction at the initiation of the turn. The right hip then adducts towards neutral (0 degrees) and continues to maximum adduction  $66\% \pm 11.8\%$  into the sequence, at which point the hip starts to abduct. The left hip, starting near maximum adduction continues adducting, reaching maximum average adduction angle of  $-32 \pm 9.3$  degrees 20% into the progression, and then reverses the sequence abducting to a maximum average angle of  $29.2 \pm 6.9$  degrees  $65\% \pm 3.7\%$  into the sequence. Following maximum abduction, the hip again adducts continuing into the next turn. Because maximum abduction occurs with maximum adduction of the other leg, there are two instances during the turn sequence during which the right and left hip angles are the same. The first instant occurs while the right hip is abducting and the left is adducting  $45.6\% \pm 8.7\%$  into the turn with an average of

12 degrees adduction in both hips. The same hip angle occurs again  $87\% \pm 8.3\%$  into sequence as both hips are adducted an average of 15 degrees (Fig. 4.6). The average maximum left hip abduction occurs at  $65\% \pm 3.7\%$  and average maximum right hip adduction takes place at  $66\% \pm 11.8\%$  into the turn.

**Table 4.4. Hip abduction/adduction**

Subject	RIGHT HIP (degrees)			LEFT HIP (degrees)		
	adduct	abduct	ROM	adduct	abduct	ROM
1	-30	38	68	-42	44	86
2	-21	35	56	-41	25	66
3	-26	26	52	-28	20	48
4	-17	25	42	-25	-4	21
5	-20	22	42	-22	-9	13
Ave $\pm$ sd	$-23 \pm 5.2$	$29.2 \pm 6.9$	$52 \pm 10.9$	$-32 \pm 9.3$	$15.2 \pm 21.8$	$46.8 \pm 30.5$

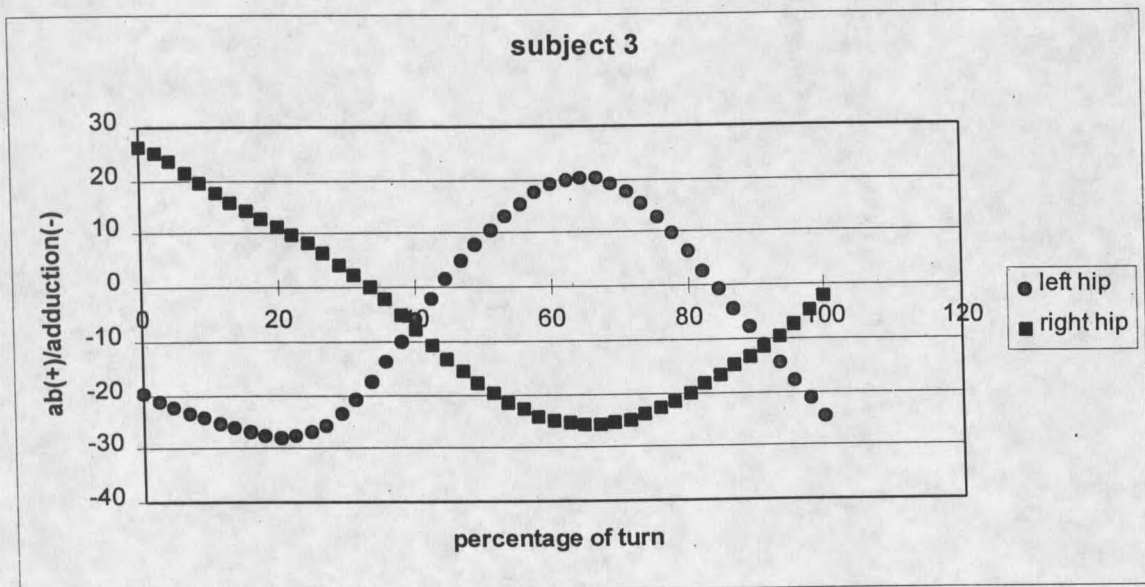

**Figure 4.6. Hip ab/adduction ROM during the telemark turn.**

Internal and external rotation ROM of the lower limbs are shown in Table 4.5. The average ROM for the right hip is  $25 \pm 7.9$  degrees and the left hip is similar with an average ROM of  $26.2 \pm 9.3$  degrees. The lower limbs are initially rotated to the right of the skiers' anterior/posterior axis, such that the right lower limb is externally rotated and the left lower limb is internally rotated. At the beginning of the turn, the lower limbs begin to rotate towards the left as the right lower limb internally rotates and the left lower limb externally rotates approaching zero. At  $35\% \pm 5.4\%$  into the sequence, the lower limbs are in a neutral position and then continue in the direction left of the anterior/posterior axis reaching maximum left lower limb external rotation and right lower limb internal rotation. The lower limbs then swing back past neutral towards the right of the skiers' anterior/posterior axis at the completion of the sequence (Fig. 4.7). Both lower limbs followed similar positions relative to the body because the legs are used to steer the skier through the turn. Figures 4.8a,b, 4.9a,b, and 4.10a,b show the angle/angle graphs of the hip motion about all three axis.

**Table 4.5. Leg rotation.**

Subject	RIGHT LEG ROTATION (degrees)			LEFT LEG ROTATION (degrees)		
	internal	external	ROM	internal	external	ROM
1	-13	14	27	-18	15	33
2	-15	21	36	-21	18	39
3	-5	19	24	-19	2	21
4	0	23	23	-19	1	20
5	-1	13	14	-15	3	18
Ave $\pm$ sd	$-7 \pm 6.8$	$18 \pm 4.4$	$25 \pm 7.9$	$-18.4 \pm 2.2$	$8 \pm 8.0$	$26.2 \pm 9.3$

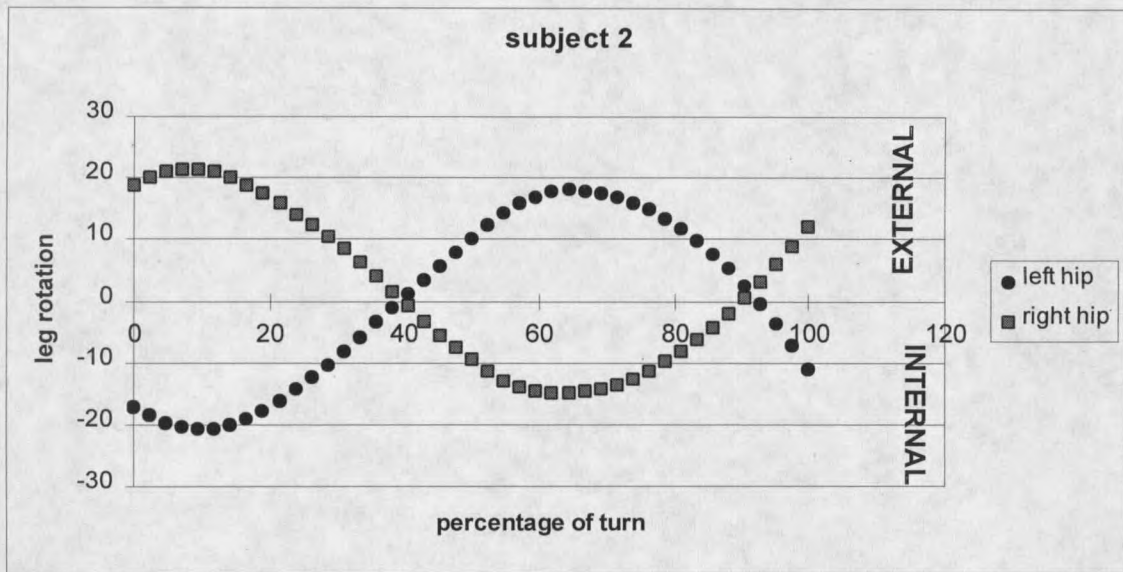

Figure 4.7. Internal and external leg rotation during the telemark turn.

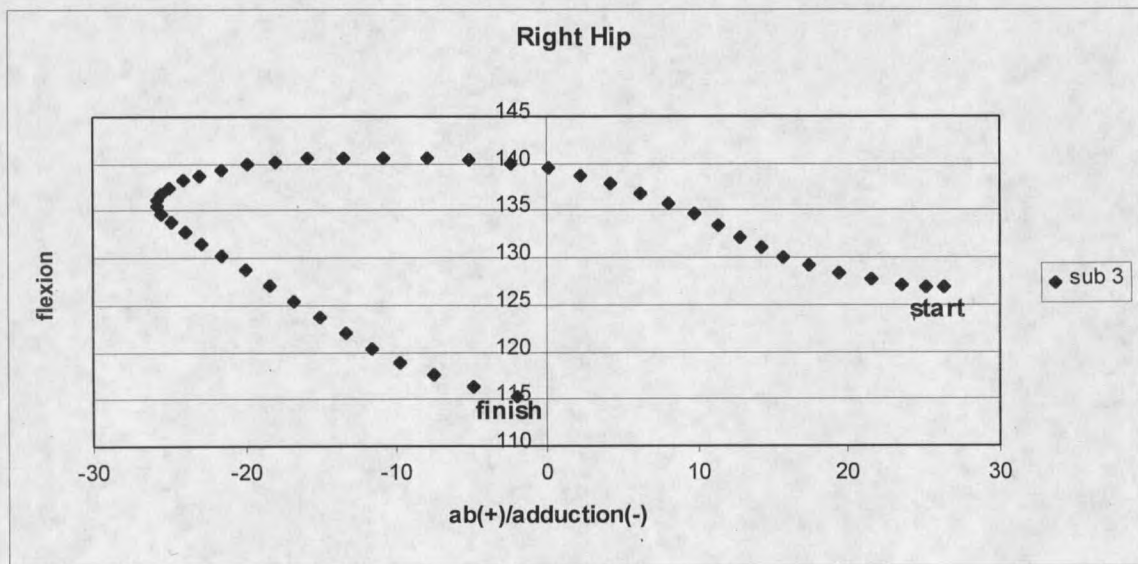

Figure 4.8a. The relationship between flexion and ab/adduction of the right hip during the telemark turn.

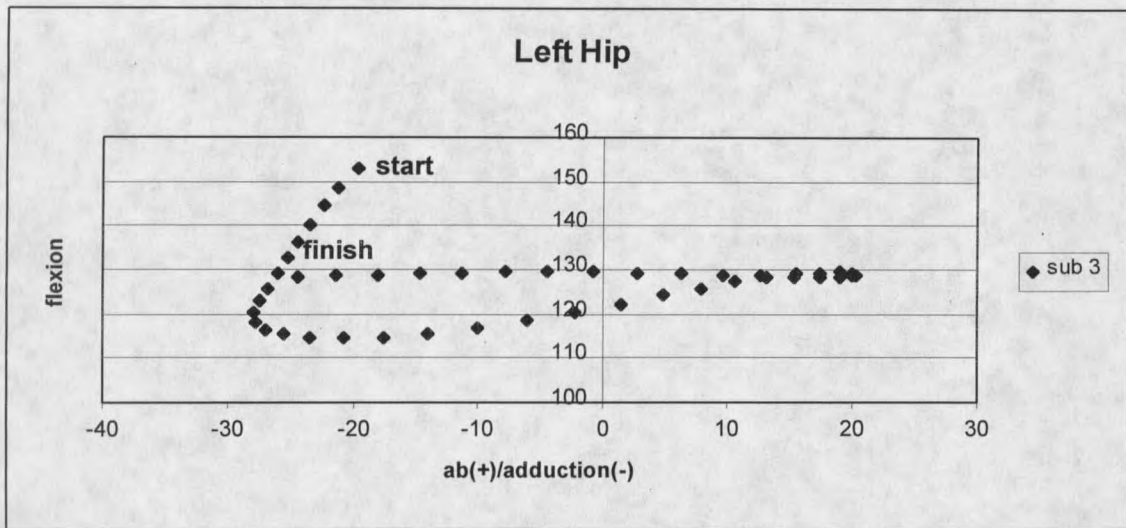

Figure 4.8b. The relationship between flexion and ab/adduction of the left hip during the telemark turn.

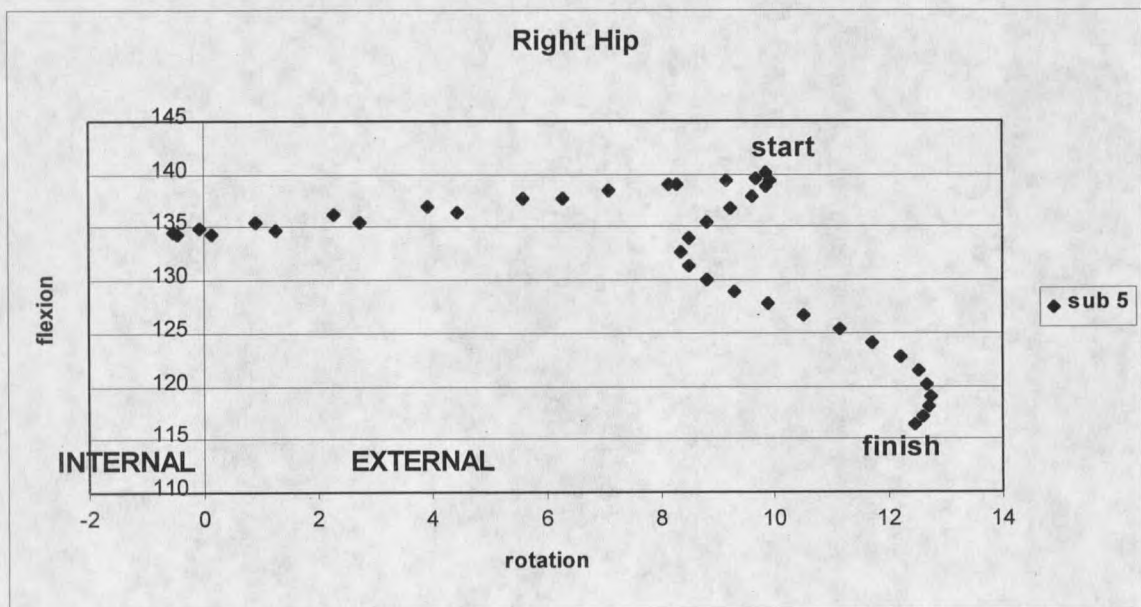

Figure 4.9a. The relationship between flexion and rotation of the right leg during a telemark turn.

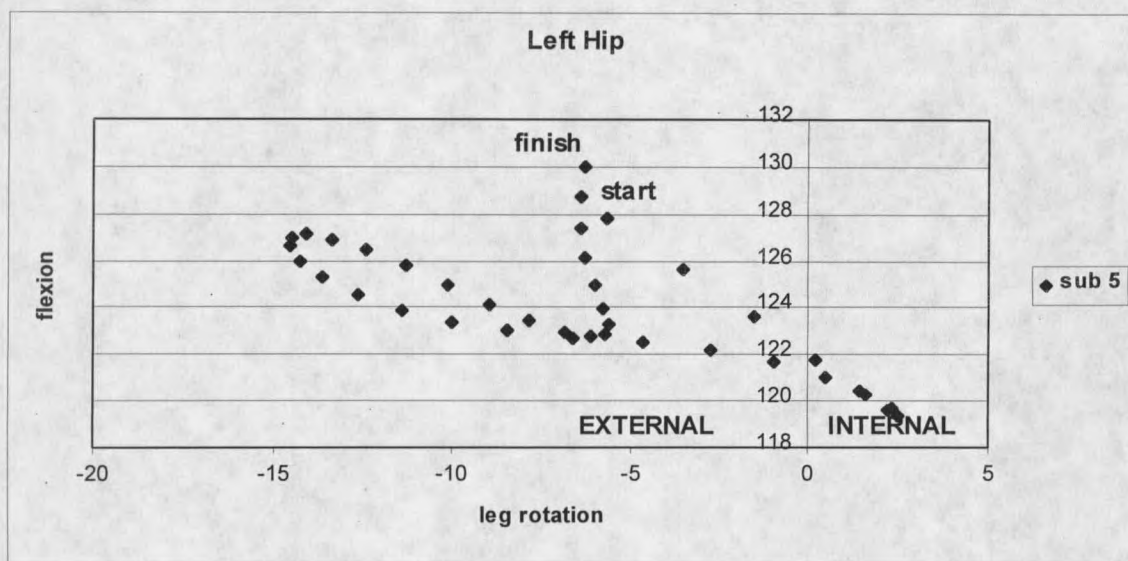

Figure 4.9b. The relationship between flexion and rotation of the left leg during a telemark turn.

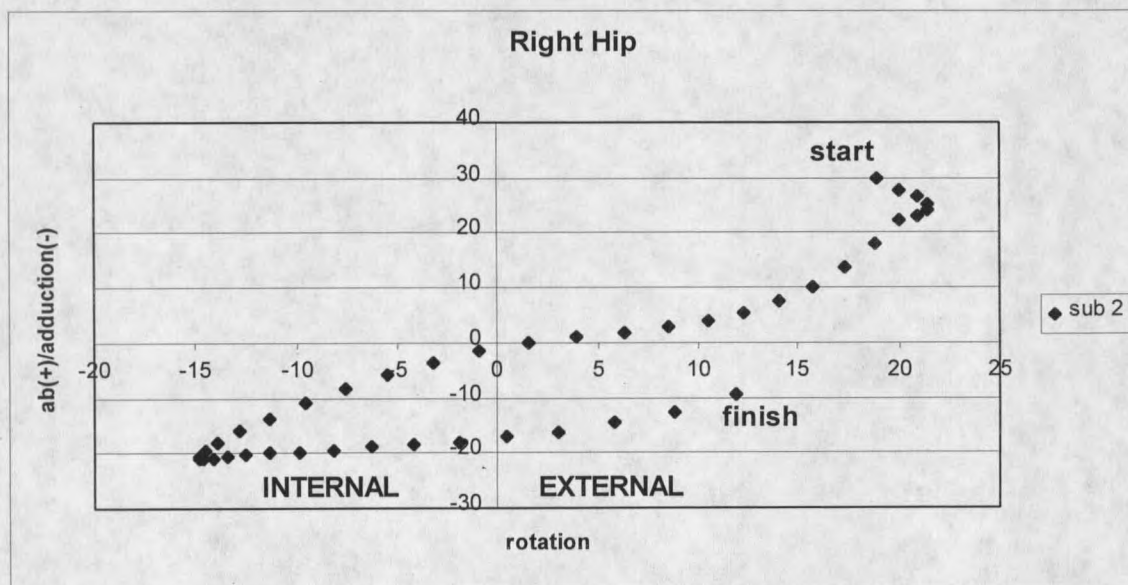
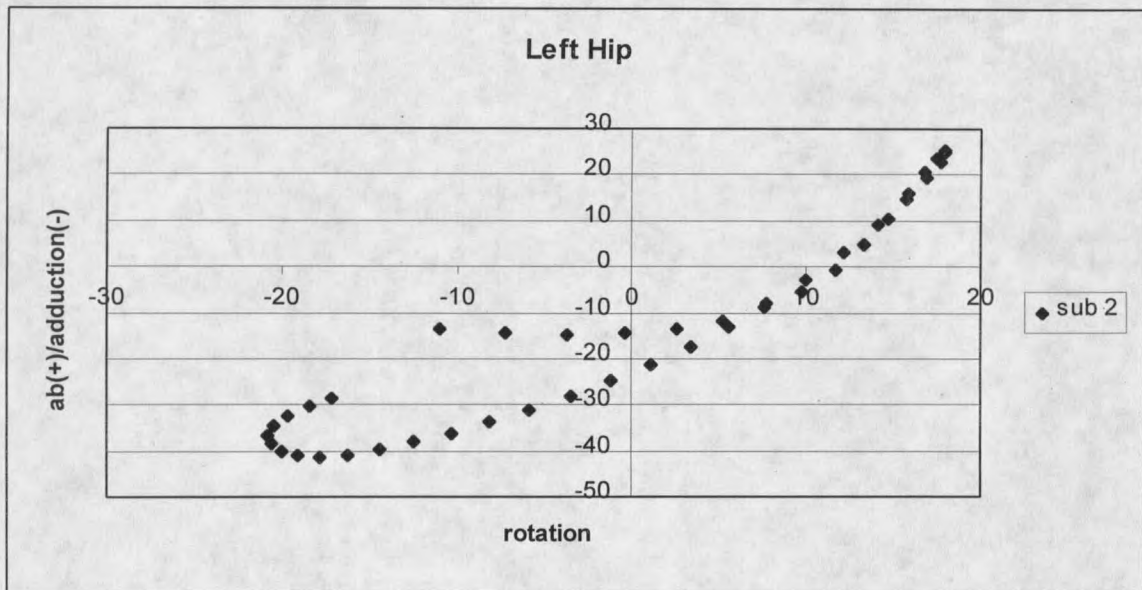

Figure 4.10a. The relationship between rotation and ab/adduction of the right leg during a telemark turn.



**Figure 4.10b. The relationship between rotation and ab/adduction of the left leg during a telemark turn.**

Pelvis rotation relative to the fall line is shown in Table 4.6. Average pelvis ROM was  $77 \pm 9.9$  degrees. At the initiation of the sequence, the pelvis was rotated to the left of the fall line with positive rotation values. The pelvis rotated in the direction of the fall line and reached a neutral, non-rotated position on average  $35\% \pm 5.4\%$  into the turn. The pelvis continued to rotate to the right reaching maximum right rotation  $74\% \pm 5.1\%$  into the sequence. The average maximum pelvic angle to the right of the fall line was  $-36 \pm 7.1$  degrees. The pelvis then change direction in conjunction with the following pole plant and rotated towards the left initiating the ensuing turn (Fig. 4.11).

Table 4.6. Pelvis rotation.

Subject	PELVIC SEGMENT (degrees)		
	max right	max left	ROM
1	-43	41	84
2	-45	45	90
3	-33	41	74
4	-32	40	72
5	-29	36	65
Ave $\pm$ sd	$-36 \pm 7.1$	$41 \pm 3.2$	$77 \pm 9.9$

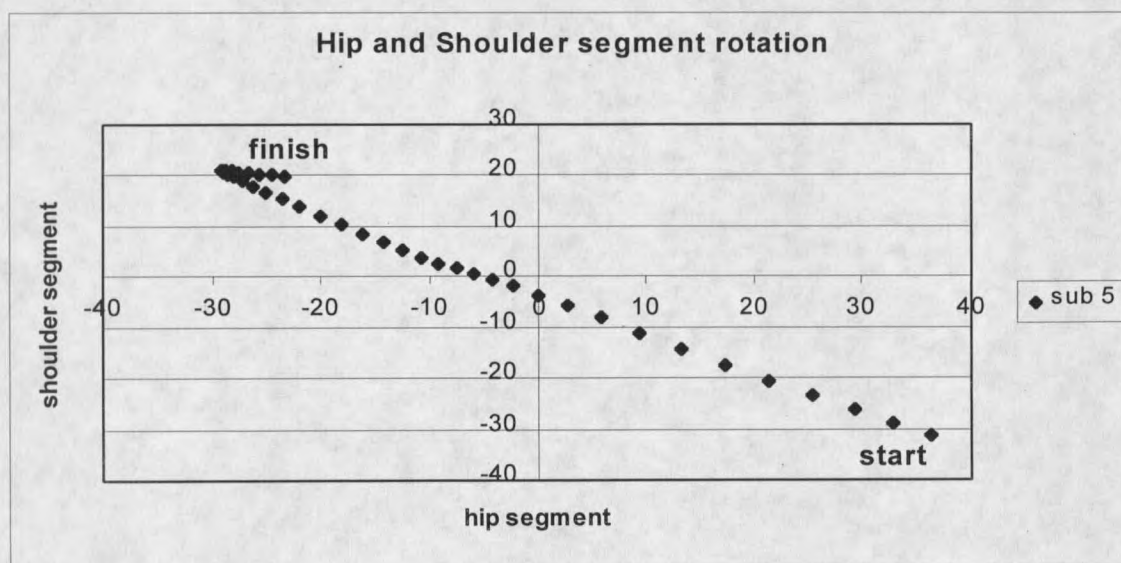

Figure 4.11. The relationships between pelvis and shoulder rotation during a telemark turn.

### Upper Extremity

Shoulder segment rotation relative to local axis system is displayed in Table 4.7. The average ROM for shoulder rotation was  $39.6 \pm 11.5$  degrees. The shoulder segment was initially rotated to the right of the pelvis. The shoulders continue to rotate to the right reaching a minimum value of  $-24 \pm 9.5$  degrees at  $14\% \pm 5.9\%$  into the turn. The shoulder segment then reversed

direction and rotated to the left. The shoulders were aligned with the pelvis, zero rotation  $41\% \pm 10.4\%$  into the turn. The shoulder segment continued rotating to the left reaching average maximum left rotation of  $16 \pm 7.7$  degrees  $83\% \pm 13.2\%$  into the sequence, occurring shortly after left hand pole plant. The shoulder segment then rotates back towards the right throughout the remainder of the turn. Figure 4.11 shows the relationship between shoulder and hip rotation during the turn sequence.

**Table 4.7. Shoulder segment rotation.**

Subject	Max Right Rotation	Max Left Rotation	ROM (degrees)
1	-22	12	34
2	-28	4	32
3	-30	22	52
4	-8	20	28
5	-31	21	52
Ave $\pm$ sd	$-24 \pm 9.5$	$16 \pm 7.7$	$39.6 \pm 11.5$

Shoulder tilt ROM is shown in Table 4.8. During the initiation of the turn sequence at right hand pole plant, the right shoulder was lower than the left causing the upper body to be tilted to the right, or into the turn. The average ROM of shoulder tilt was  $21.6 \pm 9.5$  degrees. The upper body continued to tilt towards the right reaching a maximum inward tilt of  $13 \pm 5.6$  degrees  $12\% \pm 8.1\%$  into the sequence. Maximum shoulder segment rotation to the right corresponded with maximum right shoulder tilt. The shoulder tilt began to change direction prior to feet becoming parallel as the right shoulder begins to elevate. The right shoulder continued to elevate reaching zero degree angle, or neutral position  $35\% \pm 11.4\%$  into the turn. As the right shoulder elevates, the

left shoulder depresses such that the skier is tilted to the left. The left tilt continues to the minimum average angle of  $-9 \pm 5.2$  degrees,  $61\% \pm 12.7\%$  into the turn sequence. Then the right shoulder begins to depress again reaching zero degrees at  $95\% \pm 2.6\%$  into the turn (Fig. 4.12).

**Table 4.8. Shoulder segment tilt.**

Subject	Left Shoulder Down	Right Shoulder Down	ROM (degrees)
1	-1	10	11
2	-7	12	19
3	-11	21	33
4	-9	6	15
5	-15	15	30
Ave $\pm$ sd	$-9 \pm 5.2$	$13 \pm 5.6$	$21.6 \pm 9.5$

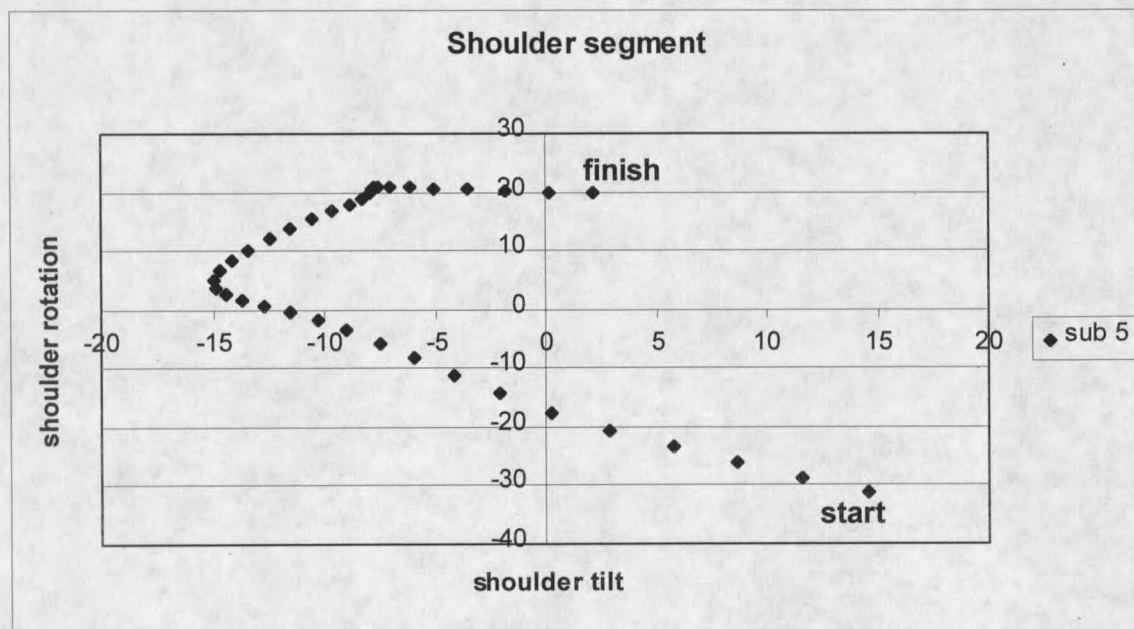

**Figure 4.12. The relationship between shoulder tilt and shoulder segment rotation during a telemark turn.**

Forward lean angle of the skier while negotiating a telemark turn is presented in Table 4.9. Average forward lean ROM was  $12.8 \pm 4.6$  degrees. The trunk angle decreased as the skier initiated the telemark position from feet parallel prior to the steering of the skis through the turn (Fig. 4.13). The skier was in a position of average maximum forward lean of  $21 \pm 4.9$  degrees at the beginning of the sequence. The flexion angle of the trunk decreased to the average minimum of  $8.4 \pm 2.2$  degrees. The trunk flexed forward during the latter portion of the sequence and reached maximum forward lean angle during the initiation of the next turn.

**Table 4.9. Forward lean**

Subject	FORWARD LEAN (degree)		
	min	max	ROM
1	11	23	12
2	9	28	19
3	5	18	13
4	8	21	13
5	9	15	6
Ave $\pm$ sd	$8.4 \pm 2.2$	$21 \pm 4.9$	$12.8 \pm 4.6$

The COM displacement of each subject is presented in Table 4.10. The COM shifts in all three planes during the turn. The average ROM of anterior/posterior COM shift along the anterior/posterior axis from the mid point of the hips was  $4.3 \pm 1.5$  cm. The average ROM of vertical up/down shift along the longitudinal axis of the skier perpendicular to the snow surface was  $34.9 \pm 3.6$  cm (Fig. 4.3). The movement of the COM followed similar patterns for all subjects (Fig. 4.14). The COM initially moved forward in the anterior/posterior direction accompanied by an upward movement in the vertical direction. Then the COM shifted in the posterior direction with a downward shift along the longitudinal axis

while steering the skis through the turn. Finally, the COM moved forward and up at the completion of the sequence initiating the subsequent turn.

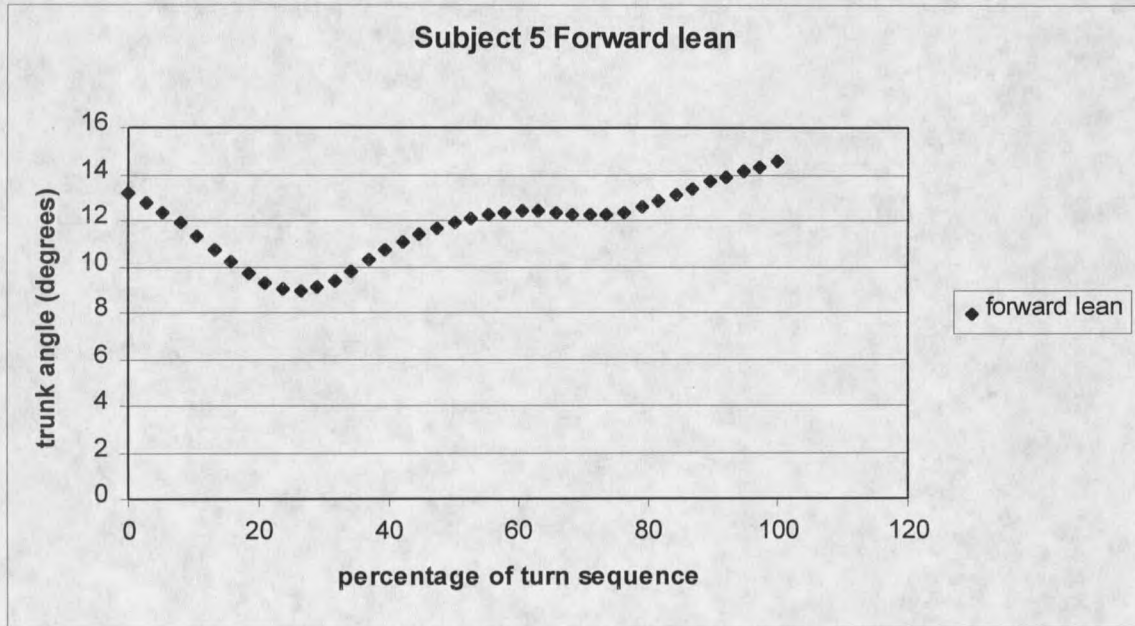

**Figure 4.13. Trunk flexion angle during the telemark turn.**

The COM also shifted medially and laterally as the skier goes through the turn. The COM was at the average maximum lateral position of  $5.9 \pm 1.1$  cm to the left of the mid line of the body at the beginning of the sequence, and then moved to the right, crossing the mid line of the body on average  $33\% \pm 8.3\%$  into the turn. The COM continued with the right lateral shift to an average maximum position of  $-6 \pm 1.5$  cm during the steering of the skis, and then began to move towards the left during the completion of the turn.

Table 4.10. Shift in the Center of Mass (COM).

Subject	COM shift ant/pos (cm)			COM shift up/down (cm)			COM shift med/lat (cm)		
	pos	ant	ROM	down	up	ROM	left	right	ROM
1	7.4	10.3	2.9	61.6	95.9	34.3	-8.1	4.7	12.8
2	5.1	9.9	4.8	60.9	99.6	38.7	-6.4	7.5	13.9
3	3.7	10.4	6.7	60.1	89.7	29.6	-4.7	6.4	11.1
4	5.5	9.3	3.8	55.7	93.5	37.8	-6.3	4.8	11.1
5	5.8	9.2	3.4	58.9	93.2	34.3	-4.3	5.9	10.2
Ave $\pm$ sd	5.5 $\pm$ 1.3	9.8 $\pm$ 0.6	4.3 $\pm$ 1.5	59.5 $\pm$ 2.4	94.4 $\pm$ 3.7	34.9 $\pm$ 3.6	-6 $\pm$ 1.5	5.9 $\pm$ 1.1	11.9 $\pm$ 1.5

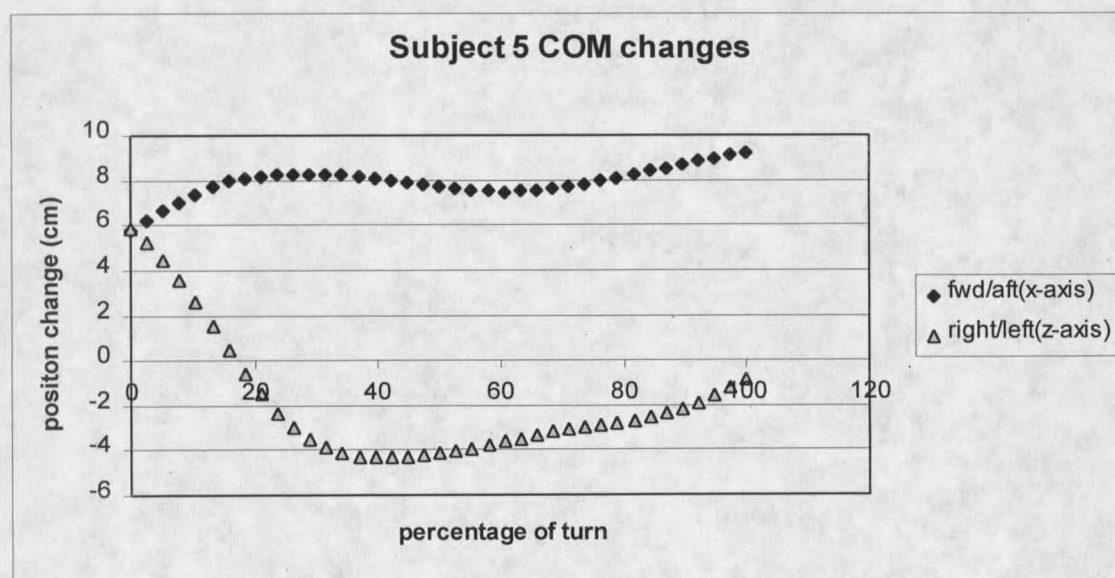

Figure 4.14. Changes in the COM during a telemark turn.

## CHAPTER V

### DISCUSSION

#### Introduction

The average velocity of the skiers was 6.3 m/sec, while rather slow, was probably a result of the short distance between the gates and the slope of the hill. However it was useful in determining the kinematics of the telemark turn. The kinematic patterns determined in the present study were generally similar to previous descriptive information regarding body position during the telemark ski turn (PSIA-NRM Level I Training Manual, Tant et al., 1992).

#### Physics Principles

##### Telemark Position and Equipment

The physics principles associated with alpine skiing become very applicable to the discipline of telemark skiing. Sliding down a hill on skis while arcing turns involves the same principles. The external forces applied to the skier are the same. The differences between the two disciplines occur because of different movement patterns of the skiers. The telemark skier works more like a flexible linked system when navigating down a hill because the heel is not fixed to the ski allowing a greater ROM of hips, knees, and ankles compared to alpine skiing. The telemark ski boot allows the skier to flex the foot at the metatarsophalangeal joint, thus altering the angle between the lower leg and the ski (Fig. 5.1). Accordingly, the knee is able to move anterior to the attachment of

the boot toe, binding, and ski interface. When in a telemark position the shank of the lead leg is perpendicular to the lead ski and the knee is positioned proximal to the foot along the perpendicular axis of the lower leg. The knee of the trail leg is positioned anterior to the foot as the trail foot lifts the heel off the ski. The telemark binding allows for anterior/posterior ROM resulting in partial lateral movement of the heel of the foot (Fig. 5.2). The lower leg is fixed during alpine skiing prohibiting movement in the anterior/posterior and lateral direction. The free heel in telemark skiing may reduce the twisting moments at the knee as compared to alpine skiing, which may decrease the risk on knee injuries.

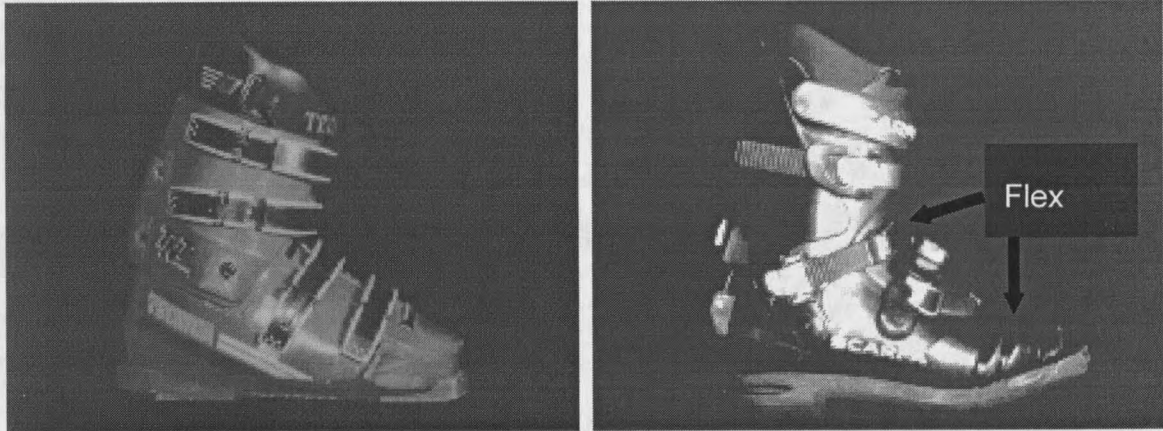

**Figure 5.1. Photo of an alpine ski boot (left) and a telemark ski boot (right).**

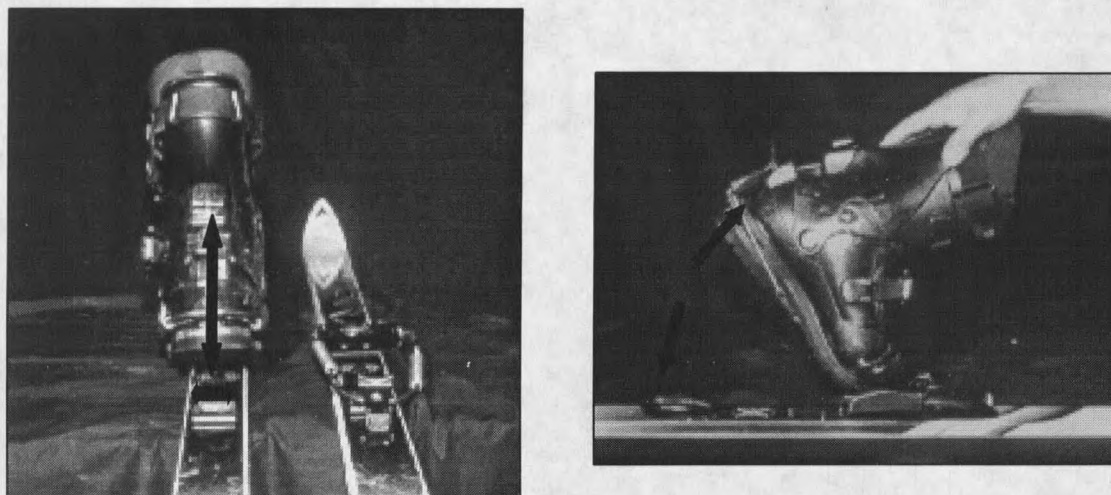

**Figure 5.2. Movement of the telemark boot in a telemark binding.**

### **Movements of the COM**

After the feet reach a parallel position, there is a decrease in the COM height as the feet shift changing the lead leg and continues to decrease to the minimum position as the skier gets into the telemark position. According to Howe (1983) the force production at the beginning of the turn is less than the force produced at the end of the turn. Similar results confirming this statement were attained from the acceleration plot in Figure 4.3. Since force production is the product of mass and acceleration and the mass of the skier remains constant, the least amount of force occurs at minimum acceleration coinciding with feet parallel.

Howe (1983) states that the greatest amount of force produced during the ski turn occurs after the body has attained minimum position. The frictional component of the ski/snow interface increases from an increase in plantar flexion and eversion of the left foot as the centrifugal and lateral adhesion forces pull the skier away from the turn (Howe, 1983). Angulation of the body by altering the

position of the hips and legs cause a change in edge angle (Fig. 5.3). As the skier begins to elevate out of the turn by extending the legs maximum force is produced as the skier resists the external forces by applying an internal force to the skis by the legs (Howe, 1983). The data attained in this study justify these principals because maximum COM acceleration occurred at minimum body position during the sequence demonstrated by Figure 4.3.

According to Howe (1983) the COM shifts forward causing greater forward pressure on the shovels of the skis in order to initiate the skidding of the tails into the turn. The telemark skier attains minimum body position in stature as he goes from the uphill quadrant to the downhill quadrant of the turn supporting principals of downhill skiing (Howe, 1983). In this study, as the COM of the skier lowered the COM shifted medially becoming positioned directly over the skis 33% into the sequence. At this point, the turn is being initiated. The COM (med/lat) continues to shift to the inside of the turn as a result of angulation from the pelvis, knees, and ankles.

### Rotary Movements

Howe (1983) mentions that movements of the upper body in the opposite direction of the lower body can create greater angulation and force production to the lower extremity and skis (Fig. 5.4). This principle was corroborated by the skiers in this study who exhibited right pelvis rotation as the shoulder segment rotated towards the left (Fig. 4.11). There is a tendency for the shoulders to lag a bit behind the actions of the pelvis. This is evident from the time line where the pelvis attain a neutral position prior to the shoulders and again as the pelvis attains maximum right rotation before the shoulders achieve maximum left rotation. The counter rotation of the pelvis to the shoulders during the latter

stages of the telemark turn sequence suggest that the pelvis is rotating to the right while driving the trailing hip into the hill, further altering the angle of the uphill edge.



**Figure 5.3. Angulation of the telemark skier during a turn.**

### **Sequence**

When all this is put together the telemark ski turn achieves an end product resembling the down motion - turn - up motion sequence desirable for skiing (Howe, 1983). This is evident by the sequence progressions (Fig. 2.4, Fig. 4.1). The up motion at the end of the turn facilitates the down motion at the beginning of the next turn. Maintaining this rhythm accompanied by counter rotation enables the telemark skier to gracefully flow from one turn to the next while giving the illusion of a non rotating, still upper body. When comparing the two disciplines the telemark skier remains more still than the alpine skier (Blackstone, 1993; Howe, 1983).

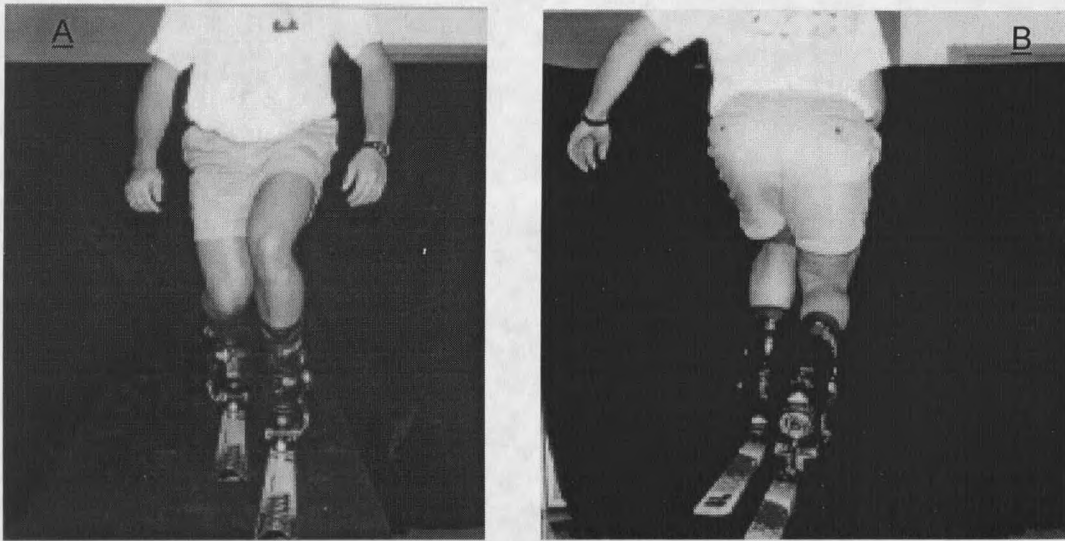

**Figure 5.4. Simulated right telemark turn front view (A). Body position and counter rotation of shoulder to hips (B).**

## Telemark ROM

### A. Hip

Maxwell and Hull (1989) reported hip and knee flexion positions and ROM during a parallel alpine ski turn. Hip flexion ROM for an alpine turn was 30 degrees for the inside leg, and 10 degrees for the outside leg (Maxwell & Hull, 1989). The telemark turn produced greater hip flexion ROM of  $38 \pm 17.1$  for the inside/uphill leg and  $27 \pm 12.0$  for the downhill/outside leg. Maxwell and Hull (1989) reported a maximum hip angle of 140 degrees and a minimum hip angle of 110 degrees for the inside leg, and a maximum hip angle of 160 degrees and the minimum hip angle of 150 degrees for the outside leg. These maximum and minimum hip flexion angles are different than the telemark data where the maximum hip angle was  $149 \pm 10.4$  and the minimum hip flexion angle was  $111 \pm 7.3$  for the inside leg. The outside leg of the telemark turn produced results of

maximum hip flexion of  $140 \pm 9.2$  and minimum hip flexion angle of  $113 \pm 9.2$ . These results show that the telemark skier is in a lower position with greater hip flexion than the alpine skier is.

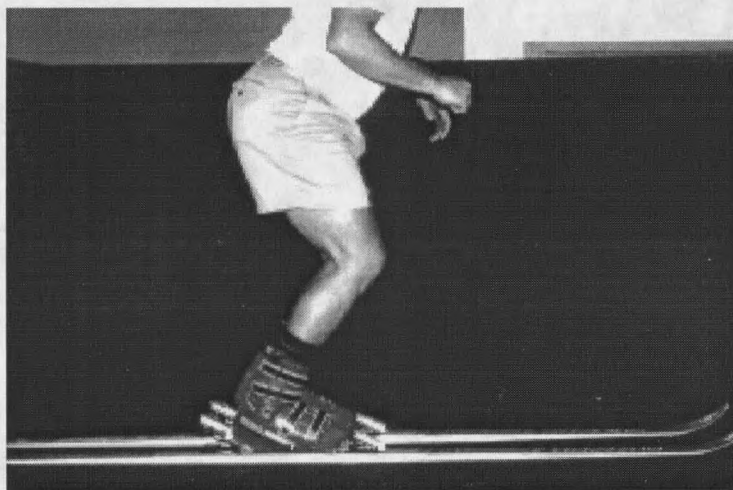

**Figure 5.5. Position of an alpine skier.**

### **B. Knee and ankle**

Maxwell and Hull (1989) reported knee flexion ROM was 20 degrees for the inside leg and 10 degrees for the outside leg during an alpine parallel ski turn. The maximum knee angle was 120 degrees and the minimum knee angle was 95 for the inside/uphill knee, and the maximum knee angle was 125 degrees and the minimum knee angle was 115 degrees for the outside/downhill knee during the parallel alpine turn (Maxwell and Hull, 1989). Muller (1994) reported knee flexion angles of 115 degrees for the uphill ski and 125 degrees for the downhill ski and these angles remained fairly constant during a parallel alpine ski turn on a packed surface. The telemark skiers in this study had a flexion range from  $88 \pm 6.8$  to  $124 \pm 7.1$  degrees for the uphill knee and  $100 \pm 3.9$  to  $119 \pm 5.2$  for the downhill knee on similar terrain.

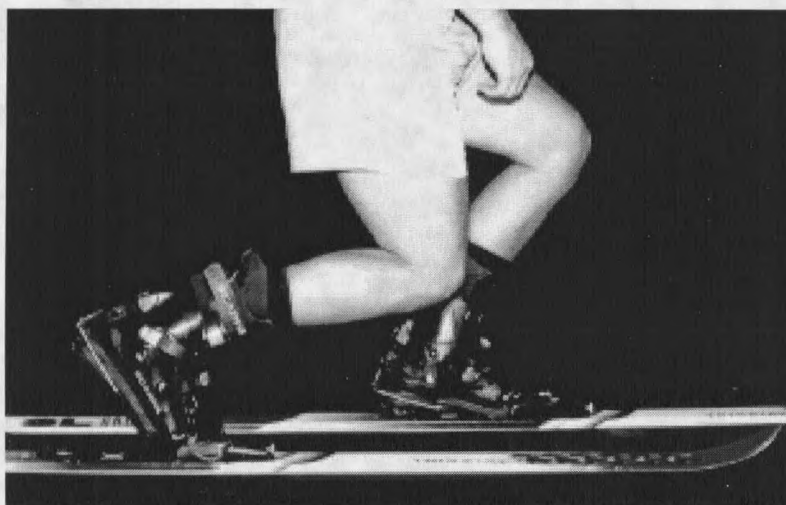

**Figure 5.6. The body position of a telemark skier from the side in the telemark position.**

It is likely that the joint moments will be different because the different body positions associated with telemark skiing will create different moment arms for the joint forces. These varying positions result from the flexibility allowed in the ankle. An alpine ski boot allows ankle flexion of about 45 degrees about the neutral angle of 20 degrees (Quinn & Mote, 1992). The telemark data produced ankle flexion ROM of  $37 \pm 15.8$  and  $29 \pm 16.3$  for the inside/uphill/right and outside/downhill/left ankle respectively. It is difficult to compare these results due to the manner in which the data were attained. Quinn and Mote (1989) attached a goniometer to the binding along the axis of the lower leg to produce the alpine skier results of the ankle. The telemark data had the foot flexing causing movement at the ankle while attaining a completely different body position. The free heel in telemark skiing caused the differences in body position when comparing the two disciplines of skiing.

The alpine skier's ankle flexion affects the force and moments produced at the tibia (Quinn & Mote, 1992). Since the foot is able to flex at the toe causing the heel to lift from the ski a different free body diagram is necessary to calculate the forces of the lower extremity that allow for the changes in body position during a telemark skiing. Figure 5.7 shows a free body diagram of an alpine skier with a fixed ankle angle. Maxwell and Hull (1989) calculated the forces and moments of the knee and the translation of the tibia on the femur with a fixed ankle angle. Figure 5.8 is a free body diagrams of the telemark skier when in the telemark position. Figures 5.9 and 5.10 break down the telemark skier to show forces and moments produced in three dimensions by using two 2-D free body diagrams. These figures show the difference in forces among the two types of skiing.

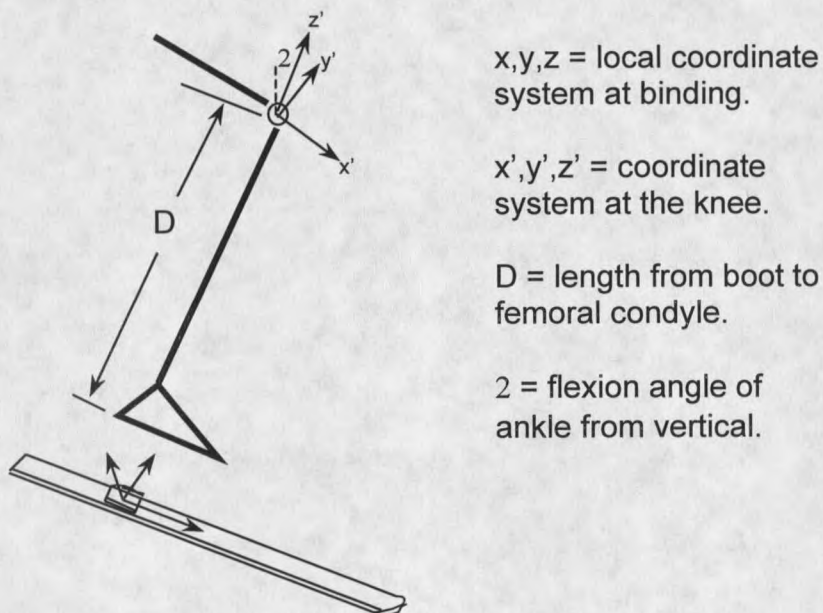

**Figure 5.7. Free body diagram of an alpine skier leg with fixed ankle angle (appendix C) (adapted from Maxwell and Hull, 1989).**

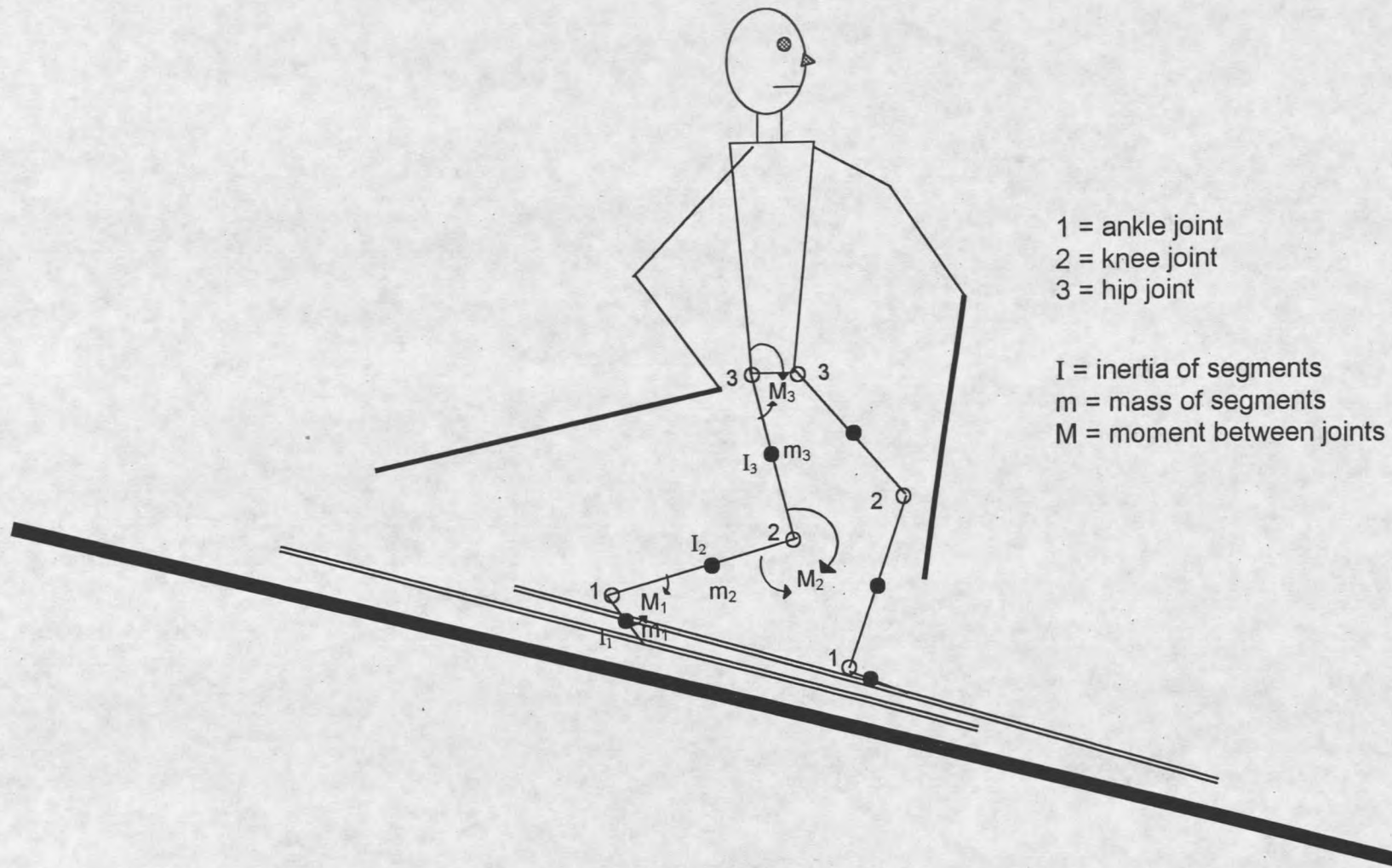

Figure 5.8. Free body diagram of the telemark skier.

1 = ankle joint  
 2 = knee joint  
 3 = hip joint

$I$  = inertia of segment  
 $m$  = mass of segment  
 $M$  = moments between joints  
 $\theta$  = segment angle

$F_x$  = force in the x direction  
 $F_y$  = force in the y direction

GRF = ground reaction force

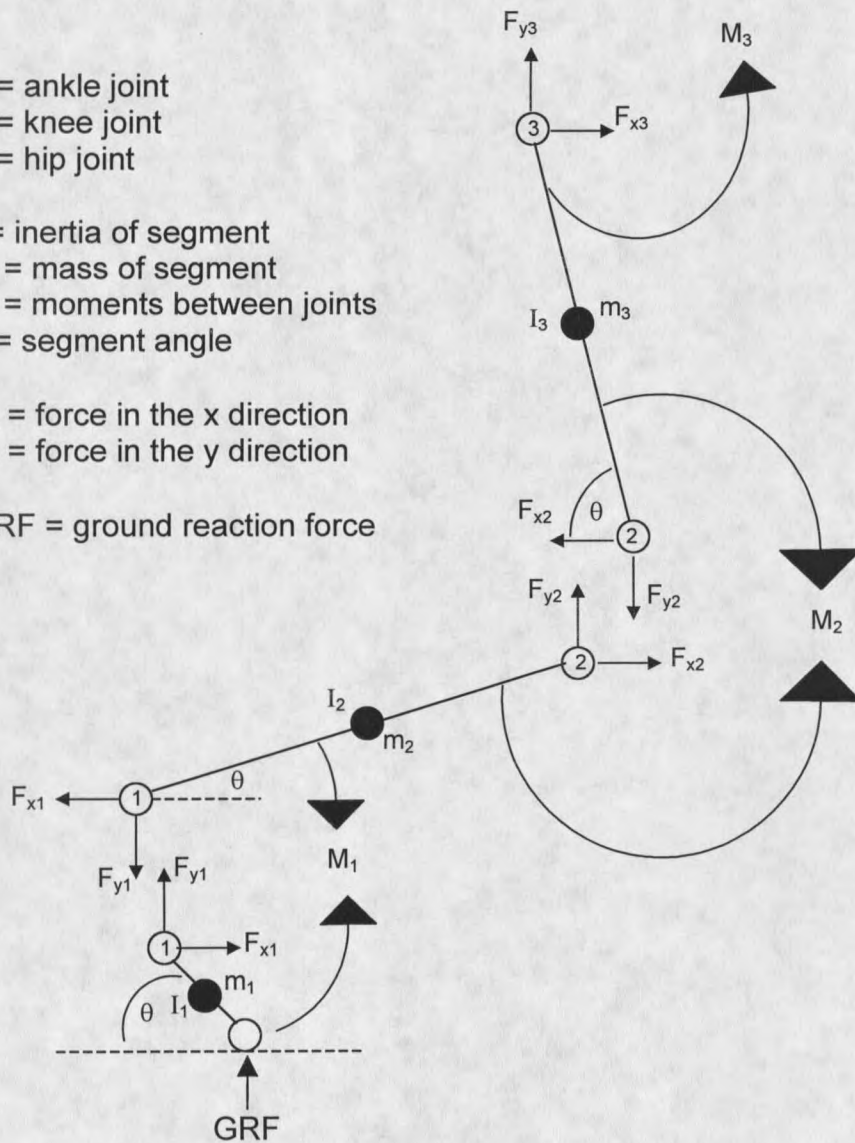

Figure 5.9. A free body diagram of the trail leg during a telemark turn in the sagittal plane (appendix C).

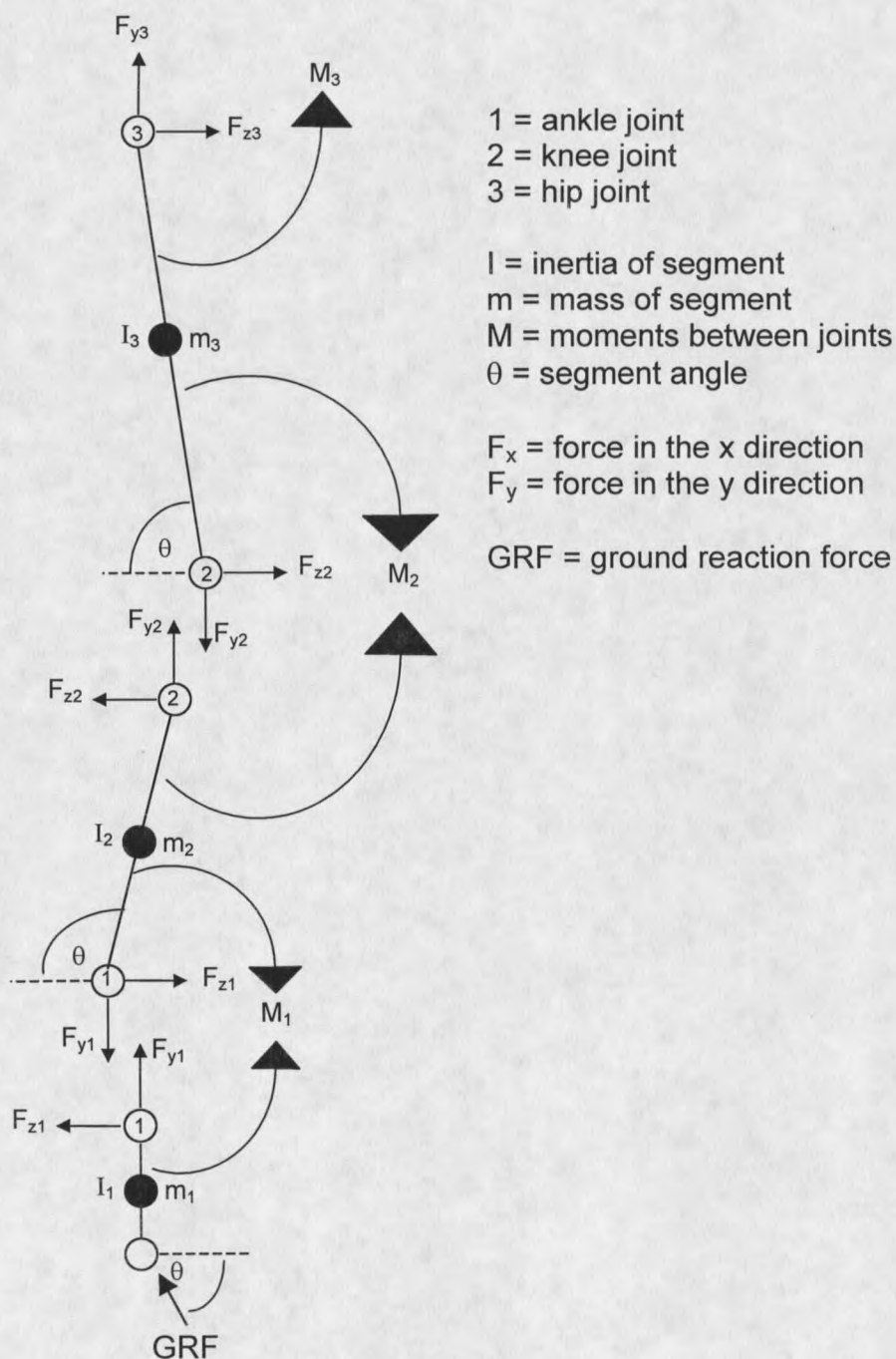

Figure 5.10. A free body diagram of the trail leg during a telemark turn in the frontal plane (appendix C).

## Kinematics

The kinematic results reflect a right hand turn initiated at right pole plant, which curtails with the feet becoming parallel after the left pole plant commencing a left-hand turn. The right hand pole plant is actually the conclusion of the previous left-hand turn as the body raises out of the turn (PSIA-NRM Level I Training Manual). The telemark turn begins as the feet stride into a telemark position from a parallel foot position (Blackstone, 1993, PSIA-NRM Level I Training Manual, Tant et al., 1992). This is accomplished by switching the lead and trail legs from the previous turn. Initiating a right hand turn has the left leg sliding forward becoming the lead leg while the right leg moves backward to become the trail leg. The telemark position is accompanied by the lowering of the hips caused by right hip extension and left hip flexion, flexion of the knees, right ankle dorsiflexion and left ankle plantar flexion. The knee of the trail leg approaches the ski resulting from the movements of the right leg. These results agree with the description from Tant et al., (1992).

The right pole plant takes place at zero percent into the described turn sequence with left pole plant occurring at  $80\% \pm 4.8\%$ . Identical hip flexion angles of 127 degrees occur shortly after pole plant at  $10\% \pm 2.5\%$  and  $88\% \pm 6.5\%$  into the sequence. The feet become parallel at  $19\% \pm 4.5\%$  and  $100\% \pm 5.7\%$  into the turn sequence at which time identical angles happen at the knees and ankles of 110 and 90 degrees respectively. All subjects displayed similar results with identical hip flexion angles occurring before the synchronization of the knee and ankle angles. The initial extension of the left hip and flexion of the right hip along with extension of the left knee and flexion of the right knee from pole plant to parallel cause an upward shift in the COM. The upward shift in the

COM is demonstrated by figure 4.3. The telemark skiers become tall after the pole plant as the body unweights in preparation for the turn. The skis are on their way to their new edge as the weight is being transferred to the new outside edge. These results confirm statements from the PSIA-NRM Level I Training Manual and Blackstone, (1993).

The right hip is adducting from a position of maximum abduction at right pole plant while the left hip is continuing to adduct towards maximum. Maximum left hip adduction coincides with the feet becoming parallel. During the period from right pole plant to parallel, the right lower limb is internally rotating while the left lower limb is externally rotating. The right hip is flexing, adducting, with the lower limb internally rotating from right pole plant to parallel. The left hip is extending, abducting, with the lower limb externally rotating.

The position of the shoulders from pole plant to a parallel foot position was also examined. Maximum right and left shoulder rotation occur shortly after right pole plant and prior to the feet becoming parallel. At  $14\% \pm 5.9\%$  into the sequence, the shoulder segment is rotated maximally to the right and at  $83\% \pm 13.2\%$  maximally to the left. Maximum forward lean also occurs during this period of time from pole plant to feet parallel confirming trunk flexion observed by Tant et al., (1992). All subjects attained maximum forward lean between these two points during the sequence. The data indicates that maximum forward lean results when the feet are parallel accompanied by maximum forward shift of the COM (Fig. 4.13 & Fig. 4.14).

Phase II, the force drop phase, occurs after the feet become parallel, the telemark position has been initiated and the body begins to lower (Tant et al., 1992). The right hip continues to extend as the left hip and knees continue to flex. The right ankle dorsiflexes and causes the heel of the boot to lift off the ski.

These position changes agree with Tant et al., (1992). In this position, the boot is only attached to the ski at the toe with the weight being directed through the ball of the right foot. The left foot continues to plantar flex caused by the forward movement of the left foot, flexion of the left hip, flexion in the knees, and a rearward shift in the COM with a decrease in forward lean angle. The decrease in the forward lean from the telemark position occurs as the feet begin to spread apart steering the skis into the turn. There is an increase in the forward/aft distance of the feet and a lowering of the COM. The lead foot will turn slightly inward, creating a skid, as the legs direct the skis down the fall line. The medial rotation of the lead leg and lateral rotation of the trail leg agrees with Tant et al., (1992).

At  $33\% \pm 8.3\%$  into the sequence, the position of the COM (med/lat) is zero. At  $35\% \pm 5.4$ , the pelvis is rotated to zero, the lower limbs are neutrally rotated, the shoulders are at zero shoulder tilt, and at  $41\% \pm 10.4\%$  zero shoulder rotation occurs. During this period, the velocity of the skier reaches the maximum (Fig. 5.11). The skier is in a position directed down the fall line of the hill. Maximum flexion of the left hip, maximum right knee flexion, and maximum right ankle dorsiflexion occur during this period of the sequence. At  $46\% \pm 8.7\%$  into the turn, the hips are in a position of 12 degrees of adduction, as the knees are squeezed to keep the skis together during the turn.

For most of the subjects, the right hip during this period of the sequence is extending, abducting from max adduction to neutral, and lower limb is internally rotating. Subject 5 had a similar progression but the lower limb was in an externally rotated position for the majority of the sequence. The left hip is extending slightly, abducting with the lower limb internally rotating from an externally rotated position. These movements confirm statements from Tant et

al, (1992) for the trail leg during the second phase on the turn. Individual subtleties occurred with relation to the hip and lower limb motion. Much of the changes in leg rotation may contribute to the balance of the skier.

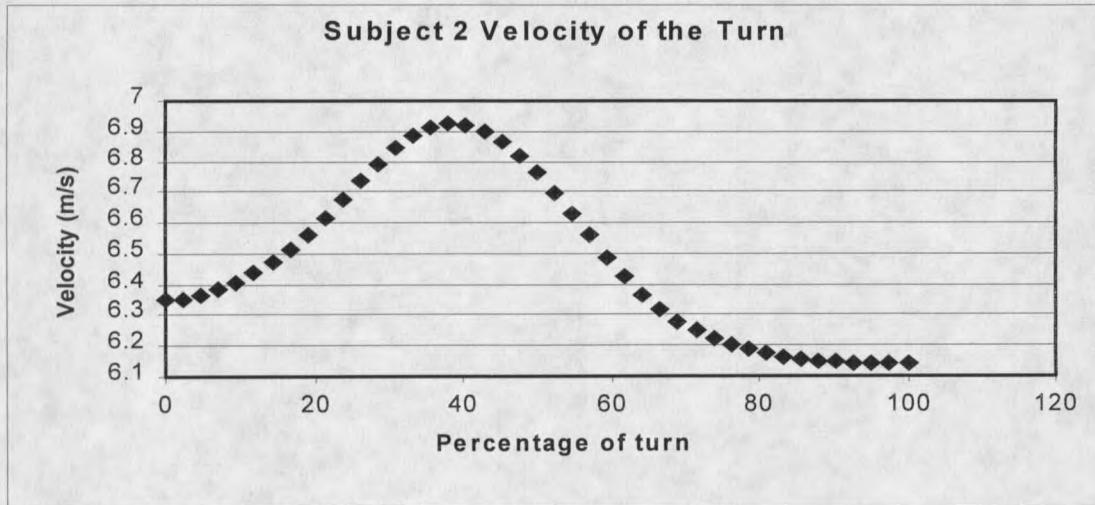

**Figure 5.11.** The velocity of a telemark skier turning during the sequence.

The COM (med/lat) shifts towards the right of center as the skier leans into the turn transferring the weight onto the new outside edge. The angulation is caused by the upper body beginning to counter rotate to the outside of the new turn. These results confirm statements from Blackstone, (1993) and Tant et al., (1992) regarding shifts in the COM and body position as the skier increases the angle between the ski/snow interface to initiate steering. The lower body achieved a neutral position prior to the shoulders. The lower body is rotating towards the right as the upper body rotates towards the left and “diagonal body position” results agreeing with statements made by Tant et al., (1992) regarding lateral flexion of the trunk causing the body to lean into the turn.

Phase III, force steering phase, of the turn is the actual turning motion. The body continues to sink into a lower telemark position, evident by the minimum COM (up/down) during this portion of the turn. The body leans into the hill to put the skis on edge caused by angulation of the pelvis, legs, and feet. The body positions creating angulation during the telemark turn have many similarities to alpine skiing proposed by Howe, (1983). The right hip is extending subtly while the left hip flexes, the right knee is extending with the left knee extending subtly to the maximum, and both feet are plantar flexing during this period as the body lowers the COM to the minimum position. These results of hip movement agree with Tant et al., (1992), but the knee and ankle results differ. Tant et al., (1992) states the knees are undergoing flexion and the ankles are dorsiflexing.

At  $61\% \pm 12.7\%$  into the turn, maximum left shoulder tilt occurred. At  $64\% \pm 8.6\%$  into the turn the feet were positioned with maximum forward/aft displacement. Both of these indicate that the skier has reached approximately the apex of the turn. Then at  $65\% \pm 3.7\%$  and  $66\% \pm 11.8\%$  into the turn, maximum left hip abduction and maximum right hip adduction occur respectively. The turn is completed at  $74\% \pm 5.1\%$  when the hips are rotated maximally to the right.

Positioning of the hips continues to be the most important aspect of the telemark turn (Blackstone, 1993). As the legs swing from right to left during a right hand turn, the hips are responsible for attaining the medial/lateral shift of the COM providing the necessary stability in opposing the centrifugal and lateral adhesion forces during the end of the turn. These movements comply with the principals of an alpine turn by Howe, (1983). The COM (med/lat) becomes maximally shifted to the right during this period of the turn. All subjects

demonstrated similar ROM for the COM (med/lat) shift. The right hip continued to adduct to maximum and then abducted while the left hip underwent a reciprocal motion of abduction to maximum then adduction. The legs followed a similar pattern of internal and external rotation to that of abduction/adduction. The rotation of the legs is similar to the information from Tant et al., (1992).

Subject 2 had the right lower limb internally rotating to the maximum and then externally rotating slightly deviating from the rest of the group. The left lower limb continued with external rotation to the maximum and then internally rotated. Subject 5 also demonstrated some subtle differences in rotation that may have to do with a style of maintaining a closer relationship of the feet forward/aft during the turn sequence. This technique of maintaining a more upright posture during the turn and making use of today's stiffer boots is currently taught. The stiffer boot allows for pressure to be placed on the tail of the ski. The rigid cuff incorporated into the plastic telemark boot enables the skier to increase the pressure by sliding the foot forward to provide for more active plantar flexion. The plastic cuff provides more resistance than the conventional leather telemark boot. This technique also allows for a quicker transition between turns because the feet do not fluctuate as much in the fwd/aft direction.

Subjects 2 and 5 also differed in the fwd/aft foot displacements. The distance between the lead and trail foot of subject 5 was 53 cm compared to 88 cm for subject 2. Comparing the two subjects found the ROM for the COM (up/down) was greater for subject 5. Hip flexion and ankle flexion ROM was much greater for subject 2 and knee flexion ROM was similar. These ROM's may explain the large differences in fwd/aft foot displacement between the two subjects other than the obvious height differences.

The shoulder segment during this period are continuing to rotate to the left accompanied by maximum left shoulder tilt, thus confirming Tant et al., (1992) information of left scapula depression, right scapula protraction, trunk lateral flexion, and trunk rotation. Upon reaching maximum left tilt the shoulder segment begins to move to the right towards a neutral position. The relationship between the shoulder segment and pelvis is evident from figure 4.11. The pelvis continues to rotate to the left while the shoulder segment rotates to the right. Maximum values of left pelvis rotation and right shoulder segment rotation occur as the turn is completed reaching the point of maximum "diagonal body position". The shoulder position results agree with the statement by Blackstone, (1993) that the upper body begins to become more countered as the outside shoulder is "left back" during this portion of the turn. Forward lean angle is increasing after achieving minimum angle during the previous time period, which coincides with a forward shift of the COM.

The final phase of the turn, the recovery phase starts just before pole plant as the next turn is initiated. The downhill/lead ski receives the dominant pressure while the turn is being completed (PSIA-NRM Level I Training Manual). At the completion of the turn, the body moves upward from extension of the hips and knees and dominant pressure shifts from the downhill to the uphill ski (Tant et al., 1992). In this study upward motion of the COM was accompanied by extension of the hips and knees verifying the prior statement. The feet continue to decrease the forward/aft distance as the right foot slides forward becoming the lead leg in the next left-hand turn.

Left pole plant occurs at  $80\% \pm 4.8\%$  into the sequence and at  $83\% \pm 13.2\%$  maximum left shoulder rotation occurs facilitating maximum upper body counter rotation. At  $87\% \pm 8.3\%$  into the turn, both hips are adducted 15 degrees

and at  $88\% \pm 8.9\%$  the hips are flexed 127 degrees. At  $100\% \pm 5.7\%$  into the turn, the feet become parallel, the body is maximally unweighted and the sequence starts again to the left.

The right ankle plantar flexes as the left ankle dorsiflexes and the right knee is extending to attain a similar angle to the left knee at 100% into the sequence agreeing with Tant et al., (1992). The right hip is extending as the left hip flexes to similar angles at 88% into the turn. The right hip is abducting and the right lower limb is externally rotating while the left hip is adducting and the left lower limb is internally rotating. These results produced discrepancies from Tant et al., (1992) regarding the movements of the hips during this phase. Tant et al., (1992) describe the trail hip/right as adducting, medially rotating, and returning from hyperextension which is not possible because hips do not hyperextend during skiing. The authors depict the motion of the lead hip/left as abducting, laterally rotating and extending. The shoulders continue to tilt towards the right verifying Tants et al., (1992) transverse abduction, then reaching a neutral position and continuing with right tilt. The shoulder segment remains rotated to the left but rotates towards the right as the pelvis moves in an opposite direction to a neutral position from the right. The position of the shoulder segment confirms Tant et al.'s (1992) account of right scapula retraction and left scapula elevation. The forward lean angle continues to increase as the COM (ant/pos) moves forward, the COM (up/down) rises, and the COM (med/lat) moves left towards neutral from being positioned to the right.

### Summary

The PSIA manual states that during the open telemark turn at the moment of pole touch the rear foot passes the front outside foot. Blackstone (1993) and

Tant et al., (1992) state the change in lead occurs shortly after pole plant. In this study the feet become parallel, the point of maximum unweighting, 19% after the right pole plant initiating the right telemark turn and 20% after the left pole plant initiating a left telemark turn. These results clearly demonstrate that pole plant occurs before the maximum upward COM shift and the feet becoming parallel. The pelvis is still in the uphill quadrant evident by the med/lat COM position at the time of pole plant. The pelvis counter rotates in the opposite direction before the skis are placed onto their new edge of the next turn. The change in lead legs actually occurs a considerable time after pole plant. Previous qualitative information proved to be informative, but the quantitative information in this study can be used to demonstrate the skiing motion of 5 skilled telemark skiers negotiating a predetermined tight slalom type courses. Due to the radius of the turns, the skiers were required to make short quick turns. Results may be different performing large radius telemark turns at a faster velocity. Even though the slope was minimal the skiers were required to change direction and initiate the next turn quickly. The actual turning motion took an average of  $1.43 \pm 0.13$  seconds to complete, thus a very quick turn. The skiers were able to create speed into the course as the starting area had a steeper pitch, because the course was constructed in the flat area at the base of a steep section.

The portion of the turn from pole plant to pole plant took 80% of the entire turn sequence. From a biomechanics position, the turn should be broken into a progression of phases differing from Tant et al., (1992): The first phase of the turn taking place from pole plant to parallel, this action is the first 25% percent of the turning motion. This phase is preparing the body for the next turn and should not be considered the recovery phase referred to by Tant et al., (1992). This is the unweighting phase of the turn. Tant et al., (1992) describe the preparatory

phase as striding into the telemark position. Striding into the telemark turn takes place after the feet become parallel and the body begins to sink into a telemark position more closely related to the force drop phase, the second phase according to Tant et al., (1992).

Phase II of the telemark turn takes place from parallel to the point where the skier faces directly down the fall line of the hill at zero hip rotation. This takes place during the next 20% of the sequence as the skier lowers into the telemark position. Phase III occupies the duration of the turn from the body in the position facing down the fall line to the point of minimum body position. During these two phases, the body is continuing to move in the same direction shifting towards the inside of the turn as the skier enters the downhill quadrant.

This third phase of the turn captures approximately 35% of the turning motion. The pelvis rotate into the turn and the legs become aligned in an identical adducted position initiating body angulation. The COM shifts towards the inside of the turn, minimum vertical COM position and maximum fwd/aft foot displacement accompanies the COM shift. The skis are steered along an arc during this portion of the turn. The top view of the telemark sequence (Fig 2.5) shows the skis skidding at the initiation of this phase. The PSIA manual states that the fwd/aft foot displacement is less than a boot length apart. This study refutes the statement as the maximum fwd/aft foot displacement ranged from 53.0 to 87.9 (cm) or roughly 21 to 36 inches.

The last phase on the telemark turn takes place from the point of maximum force production in the downhill quadrant to pole plant. This phase occupies the remaining 20% of the turn sequence from pole plant to pole plant. Maximum pelvis rotation is accompanied by maximum counter rotation of the shoulder segment during this portion of the turn. The telemark equipment and

the body position during the telemark turn allow for an increase in pelvic angulation and shoulder segment counter rotation. The free moving heel results in this increased pelvic angulation and counter movements of the shoulder segment. The body elevates from the minimum position at the apex of the turn as the knees extend. The COM shifts back towards the fall line and forward as more pressure is placed onto the shovels of the skis at the completion the turn. All this is preparing the body for the ensuing pole plant to initiate the next turn. The pole plant is vital in the progression of the telemark turn. The pole plant serves as a point in which to construct a turn around. This is seen during photos of the dynamic telemark turn (PSIA-NRM Level I Training manual) and telemarking through a mogul run (Blackstone, 1993). If one views these photo progressions, the pole plant clearly transpires prior the feet becoming parallel.

## CHAPTER VI

### Conclusions and Recommendations

The present investigation increases the body of knowledge of telemark skiing. Telemark skiing has increased in popularity over the last decade, as the sales of equipment continue to rise. The advents of technology and the advances made in telemark equipment have provided skiers another method of recreational descent. The information attained in the study may be used to provide additional information to instructional materials, which may lead to an increase in performance and a decrease in injuries.

The findings in this study enhanced the current body of information regarding the kinematics of the telemark ski turn. A quantitative sequence has been established relating body position along a time sequence. The actual joint angles and ROM may change while adjusting the variables of terrain, velocity, and snow conditions, but the sequence of events should remain consistent.

Future studies are warranted regarding this discipline of skiing. Incorporating other biomechanical research methods will improve the body of knowledge. The use of force plates or strain gauges to record the forces produced on each ski would be beneficial. Also, incorporating electromyography (EMG) would allow for the researcher to quantitatively determine muscle forces and actions during various points along the telemark turn sequence. The use of both these techniques would allow a comparison between the forces produced at the knee to determine if one method of skiing poses less potential for knee injuries and improve equipment.

The mechanisms for knee injuries have been studied on alpine skiing in order to develop bindings capable of sensing abnormal stresses during falls. The knee and most commonly the ACL are usually injured during skiing by any one of the following mechanisms. A forward twisting fall with an external axial load causing internal rotation of the lower leg (Mills and Hull, 1991). The backward fall causing internal rotation at the knee as the skis' inside edge is weighted causing the ski to carved inward, also known as the "phantom foot" mechanism (Johnson et al., 1989; Mills and Hull, 1991). The boot induced anterior drawer cause by hyperextension, a combination of internal rotation and hyperextension, or an intense quadriceps contraction (Aune et al., 1995). During alpine skiing with ridged boots and fixed heel, the twisting moments created by the ski during the first two mechanism of injury translate the forces directly to knee.

The free heel associated with telemark skiing may reduce these moments acting at the knee. The flexible system allows the body to work in the manner it is designed and these compromising positions may not occur or be as severe while telemark skiing. Future biomechanical research is needed to study the torques and moments produced at the knee and ankle during telemark skiing. In a review article by Elmquist, Johnson, Kaplan, & Renstrom (1994), the authors stated that knee injuries during telemarking occurred at a frequency of 25% compared to 35% for alpine skiing. The authors state the mechanism may be caused by too much external rotational force in the valgus position while negotiating a telemark turn. They believe the reduction in knee injuries may be attributed to the softer, lower boot. However, in conjunction with the softer, lower boot and the type of binding, ankle injuries were more prevalent during telemark skiing than alpine skiing at a rate of 15% to 3%.

Another hypothesis relates ACL strain to knee flexion angle and muscle activity. The strain on the ACL as a result of knee flexion angle has been studied by Beynnon, Fleming, Johnson, Nichols, Renstrom, & Pope, (1995), and knee flexibility has been examined by Louie & Mote, (1987); Quin & Mote (1992); and Mills and Hull, (1991). According to Beynnon et al., (1995) as knee flexion angles increase less strain results on the ACL. Mills and Hull, (1991) found an increase in knee flexibility with increased knee flexion angles. A reduction of ACL injuries during skiing has been linked with co-contraction of the quadriceps and hamstrings. Louie and Mote, (1987) reported an increase in torsional knee stiffness associated with co-contraction. The relationship between knee flexion and ACL strain was true for all types of contractions involving the quadriceps, hamstrings, and co-contraction of the quadriceps and hamstrings together. With the greater ROM at the knee during telemark skiing, less ACL strain should occur as a result. The greater ROM associated with telemark skiing may also result in increased muscle activity and ultimately more co-contraction of the quadriceps and hamstrings during the telemark ski turn.

Telemark skiing is believed to offer the skier a smoother ride down an incline while imposing less impact to the knees and lower back when compared to alpine skiing. The body is able to provide a better suspension system when negotiating varied terrain. Telemark skiing enhances balance and it is a very dynamic action. The legs need to be strong and well conditioned in order to enjoy this type of downhill descent. A rigorous off-season training regiment will enhance the telemark experience.

Appendix A

**SUBJECT CONSENT FORM  
FOR  
PARTICIPATION IN HUMAN RESEARCH  
MONTANA STATE UNIVERSITY**

**Functional Requirements of Telemark Skiers**

The subject for this study is \_\_\_\_\_. This subject exhibits no contraindications to performing the required skiing techniques in the situation described herein.

**Purpose:**

You are being asked to participate in a study to examine the biomechanics of a telemark turn. You are reminded that your participation is voluntary, and that you may choose not to participate, or to withdraw at a later time. This study may help us to further understand the biomechanical requirements of telemark skiing.

You were selected as a subject based upon your telemark skiing ability.

**Time Commitment:**

If you agree to participate in this study, the total time that you will be asked to participate should be between 1 and 2 hours. The data collection will be performed during one session at Bridger Bowl ski area.

**Procedures:**

If you decide to participate, you, as the subject, will be required to submit to the following procedures:

1. Ski down a predetermined course making telemark turns.
2. Videotaping of the total body during data collection.
3. Use your own telemark skiing equipment.

Prior to data collection, you will be asked to wear dark, tight fitting clothes. In order to assist in the film analysis, white tape will be placed on the clothing at the ankle, knee, hip, shoulder, elbow, and wrist joints. Information about your height, weight, and length of ski will be recorded. Prior to performing any testing, you will be allowed to ski the course and appropriate warm-up time. You will be asked to initiate telemark turns down a course consisting of four breakaway gates. You will be asked to complete 5 trial runs.

**Confidentiality:**

If you choose to participate, the data obtained will be kept as a permanent record for future reference or publication. If you choose to participate, it is necessary that your skiing be videotaped. It is asked that the tapes made in this study be made available, by

your consent, for viewing for educational purposes. If you will allow us to use the film in this way, please read and sign the attached Permission to Retain Film for Educational Purposed consent form accordingly. If you wish to participate, but do not want the film to be used beyond its research requirement, please sign the form appropriately. All data will remain confidential. A random identification number will be assigned to the data, and your name will not be use in connection with any part of the study.

**Benefit to Subject:**

You are invited to view the film of your skiing and to discuss the results. No other benefit to you as an individual is expected. Any additional information you require can be obtained by contacting Tom Trafton through the Department of Health and Human Development.

**Risks:**

The risk of experiencing pain or physical injury during this procedure is very low. You will be asked to ski in a controlled manner down the course on a very gradual slope. You should be at less risk than everyday free skiing.

**Injury and Compensation:**

No special medical arrangements have been made regarding your participation in this study. In the event that your participation in this research results in injury to you, Bridger Bowl ski patrol will follow normal mountain procedure and no compensation for such injury is available. Further information may be obtained by calling Dr. William Skelly at (406) 994-6317.

This project has been reviewed by the Human Subjects Committee, Montana State University-Bozeman. The Committee believes that the research procedures adequately safeguard the subject's privacy, welfare, civil liberties, and rights. Additional questions about the rights of Human Subjects can be answered by the Chairman of the Human Subjects Committee, Dr. Stephen Guggenheim, (406) 994-4411.

**Authorization:**

I have read the above and understand the discomforts, inconvenience, and risk of this study. Any questions that I have asked regarding the study have been answered to my satisfaction.

I, \_\_\_\_\_, agree to participate in this research. I understand that I may later refuse to participate, and that I may withdraw from the study, without prejudice, at any time. I have received a copy of this consent form.

Signed \_\_\_\_\_ Date \_\_\_\_\_ Height \_\_\_\_\_  
 Witness \_\_\_\_\_ Weight \_\_\_\_\_  
 Investigator \_\_\_\_\_ Ski length \_\_\_\_\_

**SUBJECT CONSENT FORM  
FOR  
PERMISSION TO RETAIN FILM FOR EDUCATIONAL PURPOSES**

**Functional Requirements of Telemark skiers**

I, \_\_\_\_\_ understand that the film taken of me during this study could be observed by others for educational purposes only. I also understand that my name will not be associated with the film or the study in any way.

I also understand that it is my right to deny use of the film taken of me for later viewing. If I later decide that I do not wish the film to be shown, I understand that I may contact Dr. William Skelly, Department of Health and Human Development, Montana State University-Bozeman, Bozeman, MT, 59717-0336, (406) 994-6317.

I understand that the film will be retained by Dr. Skelly in a secure location.

Yes, I, \_\_\_\_\_, give my consent to the researcher to use the film in the intended research and also for educational purposes only.

No, I, \_\_\_\_\_, do not give my permission to use the film taken of me for use beyond the intended research.

signature of subject \_\_\_\_\_

Date \_\_\_\_\_

signature of researcher \_\_\_\_\_

Date \_\_\_\_\_

Appendix BSmoothing parameters for subject 1.

Smoothing parameters are representative of all subjects. The smoothing values among all subjects were similar to the nearest 0.01.

<u>JOINT #</u>	<u>NAME</u>	<u>X-fit</u>	<u>Y-fit</u>	<u>Z-fit</u>	<u>ALGORITHM</u>
1	R. ski tail	.053	.014	.037	cubic
2	R. ski tip	.051	.020	.035	cubic
3	R. foot	.045	.023	.020	cubic
4	R. ankle	.033	.018	.020	cubic
5	R. knee	.033	.022	.020	cubic
6	R. hip	.024	.015	.012	cubic
7	R. shoulder	.022	.018	.015	cubic
8	R. elbow	.041	.023	.021	cubic
9	R. wrist	.036	.028	.025	cubic
10	R. pole	.068	.042	.040	cubic
11	L. pole	.065	.035	.045	cubic
12	L. wrist	.044	.035	.035	cubic
13	L. elbow	.027	.025	.017	cubic
14	L. shoulder	.032	.020	.015	cubic
15	L. hip	.025	.021	.016	cubic
16	L. knee	.018	.021	.013	cubic
17	L. ankle	.032	.022	.022	cubic
18	L. foot	.025	.018	.020	cubic
19	L. ski tip	.059	.020	.035	cubic
20	L. ski tail	.060	.018	.033	cubic
21	C.G.	.016	.015	.010	cubic

\*smoothing parameters range from 0 (no smoothing) to 1 (most smoothing).

Appendix C**Definition of forces for Fig. 2.1.**

$F_g$  = gravitational force; the weight of the skier and equipment assumed acting through the skier's center of mass (COM).

$F_N$  = the normal reaction force acting up through the skier.

$F_g \cos \alpha$  = normal force perpendicular to the slope.

$F_g \sin \alpha$  = force to accelerate mass in the direction of travel.

**Equilibrium Equations Fig. 5.7 adapted from Maxwell and Hull, 1989.**

$$F_{x'} = F_x \cos \theta - F_z \sin \theta$$

$$F_{y'} = F_y$$

$$F_{z'} = F_z \cos \theta + F_x \sin \theta.$$

$$M_{x'} = M_x \cos \theta - M_z \sin \theta = F_y L$$

$$M_{y'} = M_y + F_z L \sin \theta - F_x L \cos \theta$$

$$M_{z'} = M_z \cos \theta + M_x \sin \theta - F_y L \sin \theta$$

**Equilibrium Equations for Fig. 5.9. sagittal diagram.**Foot components (1)

$$GRF_y + F_{y1} + mg = m_1 a_y$$

$$GRF_x + F_{x1} = m_1 a_x$$

$$(GRF_x L_1 \sin \theta) + (GRF_y L_1 \cos \theta) + (F_{x1} L_2 \sin \theta) + (F_{y1} L_2 \cos \theta) + M_1 = I \alpha$$

Shank components (2)

$$-F_{y1} + F_{y2} + mg = m_2 a_y$$

$$-F_{x1} + F_{x2} = m_2 a_x$$

$$-(F_{x1} L_1 \sin \theta) - (F_{x2} L_2 \sin \theta) + M_2 + (F_{y1} L_1 \cos \theta) + (F_{y2} L_2 \cos \theta) + M_2 = I \alpha$$

Thigh components (3)

$$-F_{y2} + F_{y3} + mg = m_3 a_y$$

$$-F_{x2} + F_{x3} = m_3 a_x$$

$$-(F_{x2} L_1 \sin \theta) - (F_{x3} L_2 \sin \theta) - M_2 - (F_{y2} L_1 \cos \theta) - (F_{y3} L_2 \cos \theta) + M_3 = I \alpha$$

**Equilibrium Equations for Fig. 5.10. frontal diagram.**Foot components (1)

$$GRF_y + F_{y1} + mg = m_1 a_y$$

$$GRF_z + F_{z1} = m_1 a_z$$

$$(GRF_z L_1 \sin \theta) + (GRF_y L_1 \cos \theta) + (F_{z1} L_2 \sin \theta) + (F_{y1} L_2 \cos \theta) + M_1 = I \alpha$$

Shank components (2)

$$-F_{y1} + F_{y2} + mg = m_2 a_y$$

$$-F_{z1} + F_{z2} = m_2 a_z$$

$$(F_{z1} L_1 \sin \theta) + (F_{z2} L_2 \sin \theta) + M_2 + (F_{y1} L_1 \cos \theta) - (F_{y2} L_2 \cos \theta) + M_2 = I \alpha$$

Thigh components (3)

$$-F_{y2} + F_{y3} + mg = m_3 a_y$$

$$-F_{z2} + F_{z3} = m_3 a_z$$

$$(F_{z2} L_1 \sin \theta) + (F_{z3} L_2 \sin \theta) + M_3 + (F_{y2} L_1 \cos \theta) - (F_{y3} L_2 \cos \theta) + M_3 = I \alpha$$

## REFERENCES CITED

Ariel Performance Analysis System (APAS) Users's Manual. Produced by Ariel Life Systems, Inc. San Diego, CA.

Aune, A.K., Schaff, P., and Nordsletten, L. (1995). Contraction of knee flexors and extensors in skiing related to the backward fall mechanism of injury to the anterior cruciate ligament. Scandinavian Journal of Medicine and Science in Sports, 5, 165-169.

Beynnon, B.D., Fleming, B.C., Johnson, R.J., Nichols, C.E., Renstrom, P.A., and Pope, M.H. (1995). Anterior cruciate ligament strain behavior during rehabilitation exercises in vivo. American Journal of Sports Medicine, 23(1), 24-34.

Blackstock, B. (1993). Downhill all the way. The Professional Skier, spring, 30-34.

Boyle, J.J., Johnson, R.J., & Pope, M.H. (1985). Cross country skiing injuries. In R.J. Johnson & C.D. Mote, Jr. (Eds.), Skiing Trauma and Safety: Fifth International Symposium (ASTM STP 860). Philadelphia: American Society for Testing and Materials, Pp. 411-422.

Campbell, R.J., Ettliger, C.H., Johnson, R.J., and Pope, M.H. (1981). High-risk injury groups in downhill skiing. Skiing Trauma and Safety III, Philadelphia: American Society for Testing and Materials, Pp. 126-133.

Chen, L., Armstrong, C.W., and Raftopoulos, D.D. (1994). An investigation on the accuracy of three-dimensional space reconstruction using the direct linear transformation technique. Journal of Biomechanics, 27(4), 493-500.

Clancy, W.G., and McConkey, J.P. (1985). Nordic and alpine skiing. In R.C. Schnieder, J.C. Kenedy, & M.L. Plant (Eds.). Sports Injuries: mechanisms, prevention, and treatment. Baltimore: Williams & Wilkins, Pp. 247-269.

Dudley, C.M. (1935). 60 centuries of skiing. Brattleboro, VT: Stephen Daye Press, Pp. 17, 36, 37, 65, 73.

Ekeland, A. (1995). The knees are in danger in skiing. Scandinavian Journal of Medicine and Science in Sports, 5(2), 61-63.

Ekeland, A., and Holm, A. (1985). Injury and race completion rates in alpine competitions. In R.J. Johnson & R.J. Mote, Jr. (Eds.), Skiing Trauma and

Safety: Fifth International Symposium (ASTM STP 860). Philadelphia: American Society for Testing and Materials, Pp. 293-301.

Ekeland, A., Holtmoen, A., & Lystad, H. (1993). Lower extremity equipment-related injuries in alpine recreational skiers. The American Journal of Sports Medicine, 21(2), 201-205.

Elmquist, L., Johnson, R.J., Kaplan, M.J., & Renstrom, P. A.F.H. (1994). Nordic and alpine skiing. Sports injuries: mechanisms, prevention, treatment. Baltimore: Williams & Wilkinson, Pp. 481-500.

Eriksson, E., and Danniellsson, K. (1977). A national ski injury survey. In J.M. Figueras, (Eds), Skiing safety II, University Park Press, Baltimore, Pp. 47.

Ettlinger, C.F., Johnson, R.J., & Shealy, J.E. (1995). A method to help reduce the risk of serious knee sprains incurred in alpine skiing. American Journal of Sport Medicine, 23(5) 531-537.

Figueras, J.M., Llobert, M., Bulo, J.M., Morgenstern, R., & Merino, J.A. (1985). The evolution of knee injuries in ski accidents. In R.J. Johnson & C.D. Mote, Jr. (Eds.), Skiing Trauma and Safety: Fifth International Symposium (ASTM STP 860). Philadelphia: American Society for Testing and Materials, Pp. 141-148.

Flower, R. (1976). The history of skiing and other winter sports. New York: Methuen, Pp. 24, 58.

Freeman, C.L. (1974). Steve Rieschl's ski-touring for the fun of it. Boston: Little, Brown and Company, Pp. 8,13,158.

Garrick, J.G., & Requa, R. (1977). The role of instruction in preventing ski injuries. Physician and Sports Medicine, 5: 57.

Gerritsen, K.G.M., Nachbauer, W., and van den Bogert, A. (1996). Computer simulation of landing movement in downhill skiing: anterior cruciate ligament injuries. Journal of Biomechanics, (29)7, 845-854.

Hinrichs, R.N. and McLean, S.P. (1995). NLT and extrapolated DLT: 3-D cinematography alternatives for enlarging the volume of calibration. Journal of Biomechanics, 28(10), 1219-1223.

Hintermeister, R.A., O'Connor, D.D., Dillman C.J., Suplizio, C.L., Lange, G.W., and Steadman, R.J. (1995). Muscle activity in slalom and giant slalom skiing. Medicine and Science in Sports and Exercise, 27(3), 315-322.

Howe, J.G., (1983). Skiing mechanics. Laporte, CO: Pourde Press, Pp. 68,74-76,85-89,129-132, 134-137, 141.

Hull, M.L., and Mote, C.D. Jr. (1980). Leg loading in snow skiing: Computer analyses. Journal of Biomechanics, (13), 481-491.

Johnson, R.J., Ettliger, C.F., & Shealy, J.E. (1989). Skier injury trends. In R.J. Johnson & C.D. Mote, Jr. (Eds.), Skiing Trauma and Safety: Seventh International Symposium (ASTM STP 1022). Philadelphia: American Society for Testing and Materials, Pp. 25-31.

Johnson, R.J., Pope, M.H., & Ettliger, C. (1974). Ski injuries and equipment function. Clinics in Sports Medicine, 6, 299-307.

Johnson, R.J., Pope, M.H., & Ettliger, C. (1976). The interrelationship between ski accidents, the resultant injury, the skier's characteristics, and the ski-boot-binding system. Orthopedic Clinics of North America, 7(1), 11-12.

Jorgsholm, P., Bauer, M., Ljung, B., & Lerner, A. (1991). Downhill skiing is developing: telemarking and snowboarding injuries. Lakartidningen 88(17), 1589-1592.

Lieu, D.K., and Mote, C.D. Jr. (1985). Mechanics of the turning snow ski. In R.J. Johnson & C.D. Mote, Jr. (Eds.), Skiing Trauma and Safety: Fifth International Symposium. (ASTM STP 860). Philadelphia: American Society for Testing and Materials, Pp. 117-140.

Louie, J.K., Kuo, C.Y., Gutierrez, M.D., and Mote, C.D. Jr. (1984). Surface EMG and torsion measurements during snow skiing: Laboratory and field tests. Journal of Biomechanics, (17), 713-724.

Louie, J.K., and Mote, C.D. Jr. (1985). Torsion and bending of the lower extremity during skiing. In R.J. Johnson & C.D. Mote, Jr. (Eds.), Skiing Trauma and Safety: Fifth International Symposium. (ASTM STP 860). Philadelphia: American Society for Testing and Materials, Pp. 91-109.

Lystad, H. (1985). A one year study of alpine injuries in Hemsedal, Norway. In R.J. Johnson & C.D. Mote, Jr. (Eds.), Skiing Trauma and Safety: Fifth International Symposium (ASTM STP 860). Philadelphia: American Society for Testing and Materials, Pp. 314-325.

Maxwell, S.M., & Hull, M.L. (1989). Measurement of strength and loading variables on the knee during alpine skiing. Journal of Biomechanics, 22(6/7), 609-624.

Mills, O.S. and Hull, M.L. (1991). Rotational flexibility of the human knee due to varus/valgus and axial moments *in vivo*. Journal of Biomechanics, 24(8) 673-690.

Mossner, M., Kaps, P., & Nachbauer, W. (1996). A method for obtaining data in alpine skiing using pan-and-tilt cameras with zoom lenses. In C.D. Mote, Jr. & R.J. Johnson (Eds.), Skiing Trauma and Safety: Tenth International Symposium (ASTM STP 1266). Philadelphia: American Society for Testing and Materials, Pp. 155-164.

Mote, C.D. Jr., and Kuo, C.Y. (1989). Identification of knee joint models for varus-valgus and internal-external rotations: snow skiing experiments. Journal of Biomechanics, (22)3, 245-259.

Muller, E. (1994). Analysis of the biomechanical characteristics of different swing techniques in alpine skiing. Journal of Sports Sciences, 12(3) 261-278.

Nachbauer, W., Kaps, P., Nigg, B., Brunner, F., Lutz, A., Obkircher, G., and Mossner, M. (1996). A video technique for obtaining 3-D coordinates in alpine skiing. Journal of Applied Biomechanics, 12, 104-115.

Paletta, G.A., & Warren, R.F. (1994). Knee injuries and alpine skiing treatment and rehabilitation. Sports Medicine, 17(6) 411-423.

Pigman, B.C., & Karakla, D.W. (1990). Skiing injuries during initial military nordic ski training of a U.S. Marine Corps Battalion Landing Team. Military Medicine, 155 303-306.

Pigman, B.C., Volcheck, G.W., & Grice, G.P. (1990). Military nordic skiing injury profiles with two different types of NATO ski bindings. Military Medicine, 155 354-356.

PSIA-NRM Level I Training Manual, Pp. 3-5,20-26.

Quinn, T.P., & Mote, C.D. Jr. (1992). Prediction of the loading along the leg during snow skiing. Journal of Biomechanics, 25(6), 609-625.

Read L., and Herzog, W. (1992). External loading at the knee joint for landing movements in alpine skiing. International Journal of Sport Biomechanics, 8, 62-80.

Renstrom, P., & Johnson, R.J. (1989). Cross-country skiing injuries and biomechanics. Sports Medicine, 8(6), 346-370.

Shealy, J.E. (1985). Overall analysis of NSAA/ASTM data on skiing injuries for 1978 through 1981. In R.J. Johnson & C.D. Mote, Jr. (Eds.), Skiing Trauma and Safety: Fifth International Symposium (ASTM STP 860). Philadelphia: American Society for Testing and Materials, Pp. 302-307.

Sherry, E., & Asquith, J. (1987). Hazards of cross-country skiing. Australian Family Physician, 16: 851.

Swinson, D.B. (1992). Physics and Skiing. The Physics Teacher, 30(Nov), 458-463.

Tant, C.L., Van Gerpen-Henn, C., & Lamack, D. (1992). The telemark turn. National Strength and Conditioning Association Journal, 14(3), 6-9, 86-90.

Tejado-Flores, L., & Steck, A. (1972). Wilderness skiing. San Francisco: Sierra Club Books, Pp. 53.

Tesch, Per A. (1995). Aspects on muscle properties and use in competitive alpine skiing. Medicine and Science in Sports and Exercise, 27(3), 310-314.

Tuggy, M. (1996). Telemark skiing injuries. The Journal of Sports Medicine and Physical Fitness, 36(3), 217-222.

Young, L.R., & Crane, H.D. (1985). Thumbs up: The changing pattern of ski injuries. In R.J. Johnson & C.D. Mote, Jr. (Eds.), Skiing Trauma and Safety: Fifth International Symposium (ASTM STP 860). Philadelphia: American Society for Testing and Materials, Pp. 382-391.

Webster, J.D., and Brown, C.A. (1996). Computer simulation of the loads on the ACL during the backward falls based on an open kinematic chain model. In R.J. Johnson, C.D. Mote, Jr., Hauser, W., and Schaff, P.S. (Eds.), Skiing Trauma and Safety: Tenth Volume. (ASTM STP 1266). Philadelphia: American Society for Testing and Materials, Pp. 254-269.

MONTANA STATE UNIVERSITY - BOZEMAN



3 1762 10421048 7