

# Influence of the Distribution of the Manganese-Oxidizing Bacterium, *Leptothrix Discophora*, on Ennoblement of Type 316L Stainless Steel

S. Campbell,\* G. Geesey,\*\* Z. Lewandowski,†\*\*\* and G. Jackson\*\*\*\*

## ABSTRACT

Type 316L (UNS 31603) stainless steel (SS) was ennobled to an open-circuit potential (OCP) of 323 mV vs saturated calomel electrode (SCE) within a 5-day period due to the deposition of manganese oxides on the metal surface by a monospecies biofilm of *Leptothrix discophora*. However, the same metal experienced only partial ennoblement, achieving a maximum potential of 143 mV<sub>SCE</sub> during the same period when colonized by a three-species biofilm containing *L. discophora*, and even this level of ennoblement by the mixed-species biofilm was only transient since the potential decreased to 122 mV<sub>SCE</sub> shortly after achieving the maximum potential. The mixed-species biofilm was significantly thicker (>200 μm) than the *L. discophora* monospecies biofilm (120 μm). Using 16s rRNA probes specific for *L. discophora*, fluorescent in-situ hybridization revealed cells to be heterogeneously distributed throughout the monospecies biofilm. In the three-species biofilm, 16s rRNA probes revealed a homogeneous layer of *L. discophora* that resided proximal to the biofilm-bulk solution phase. At the most distal position from the biofilm-bulk solution phase near the glass-biofilm interface there existed very few to no *L. discophora*. Microelectrode studies revealed the presence of oxygen (3.85 mg/L to

4.35 mg/L) at the monospecies-glass substratum interface in 50% of the areas of the substratum assayed. No oxygen was detected at the three-species biofilm-glass interface where the thickness of the overlying biofilm exceeded 200 μm. The results suggest that ennoblement of Type 316L SS by *L. discophora* depends on oxygen accessibility to cells proximal to the substratum.

**KEY WORDS:** ennoblement, fluorescent in-situ hybridization, microbiologically influenced corrosion

## INTRODUCTION

Passive metals when immersed in natural waters shift the open-circuit potential (OCP) in the noble direction and elevate the cathodic current monitored when the exposed samples are cathodically polarized.<sup>1-6</sup> These combined effects, the elevated OCP and the increase in cathodic efficiency, are collectively known as ennoblement and are hypothetically prescribed to the activity of manganese-oxidizing microorganisms, and are explained by the following mechanism:

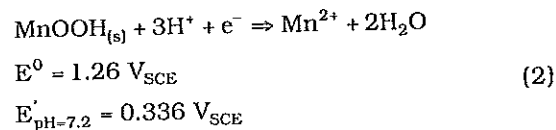
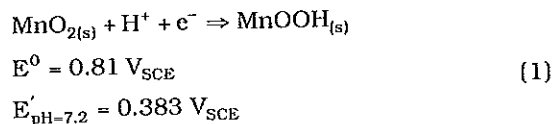

Submitted for publication March 2003; in revised form, January 2004. Presented as paper no. 03566 at CORROSION/2003, March 2003, San Diego, CA.

† Corresponding author. E-mail: zl@erc.montana.edu.

\* Department of Microbiology and Center for Biofilm Engineering, Montana State University, Bozeman, MT 59717.

\*\* Department of Microbiology and Center for Biofilm Engineering, Montana State University, Bozeman, MT 59717.

\*\*\* Department of Civil Engineering and Center for Biofilm Engineering, Montana State University, EPS Blvd., Room 316, Bozeman, MT 59717.

\*\*\*\* Center for Biofilm Engineering, Montana State University, Bozeman, MT 59717.

The overall reaction is:

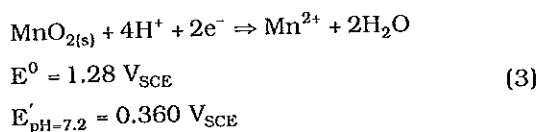

The standard potentials ( $E^0$ ) for Equations (1), (2), and (3) were calculated using the energies of formation:  $\Delta G_f^0 \text{ Mn}^{2+} = -54.5$  kcal/mole,  $\Delta G_f^0 \gamma\text{-MnOOH} = -133.3$  kcal/mole, and  $\Delta G_f^0 \gamma\text{-MnO}_2 = -109.1$  kcal/mole (<http://www.chem.ualberta.ca/courses/plambeck/p102.html>).<sup>7-8</sup>

Only a small amount of manganese oxide needs to be deposited on the surface to ennoble the metal. Dickinson demonstrated that covering just 6% of the metal surface with manganese oxides increased the OCP of Type 316L (UNS S31603)<sup>(1)</sup> stainless steel (SS) (around  $\sim 200$  mV vs saturated calomel electrode [SCE]) to the final OCP exceeding 350 mV<sub>SCE</sub>, near the reported equilibrium potential of the manganese oxides, 362 mV<sub>SCE</sub> at a pH of 7.2.<sup>9-10</sup> For that reason alone, the phenomenon of ennoblement is of interest to corrosion researchers and practitioners as elevating OCP passive metals to the levels near the pitting potential ( $E_{\text{pit}}$ ) and may increase the risk of localized corrosion, particularly if the metal is immersed in a solution of aggressive ions, e.g., chloride.

Because the mechanism of ennoblement described by Equations (1), (2), and (3) implicates involvement of manganese-oxidizing bacteria, we use in our laboratory the manganese-oxidizing bacterium, *Leptothrix discophora*, as a model microorganism to study ennoblement of SS.<sup>7-9</sup> *L. discophora* is a G-sheathed filamentous bacterium that oxidizes manganese and readily forms a biofilm. This organism produces an extracellular protein, which binds to the sheath,<sup>11</sup> and is responsible for manganese oxidation.<sup>12</sup> There is no equivocal evidence that *L. discophora* oxidizes manganese as an energy source, but possibly performs oxidation to detoxify the environment of heavy metals or to protect from grazers due to encrustation with oxides.<sup>12-16</sup> However, when the sheath becomes encrusted in oxides, the bacteria can leave their sheath and move to another location.<sup>17</sup> *L. discophora* has been shown to form a biofilm on Type 316L SS surface, deposit manganese on the surface due to attachment, and ennoble SS. Previous studies have shown that biofilms will develop microgradients of inorganic compounds and that these microgradients will affect the spatial distribution of microorganisms.<sup>18-21</sup> In sediments, chemical microgradients may have a significant impact on rates of geochemical transformations.<sup>22</sup> Chemical

microgradients form in biofilms as a result of localized microbial activity and penetration of organic and inorganic materials into the biofilm.<sup>20</sup>

We can reproduce in laboratory experiments the ennoblement observed in field experiments using the model microorganism, *L. discophora*, by depositing manganese oxides on the surface of noble metals, SS and titanium, ennobling the metal surface.<sup>7-9</sup> The laboratory results strongly support the proposed mechanism, Equations (1), (2), and (3). However, our field observations also demonstrated that the presence of manganese oxides in the microbial deposits on Type 316L SS was not always associated with ennoblement. Braughton, et al.,<sup>7</sup> showed that manganese oxides were present in the biofouling deposits on Type 316L SS without causing significant ennoblement. To accept the mechanism of ennoblement by manganese-oxidizing microorganisms, these observations had to be explained within the framework of the hypothetical mechanism given by Equations (1) through (3). To explain this apparent discrepancy between the expectations and experimental results, it was postulated that the extent of ennoblement depends on two factors:

- the presence of manganese oxides
- the structure of the biofilms deposited on the SS

Specifically, it was postulated that in mixed population biofilms, slower-growing manganese-oxidizing bacteria may be displaced from the metal surface by other faster-growing microorganisms that do not oxidize manganese. As a result, manganese oxides deposited proximal to the manganese-oxidizing populations may not be in electrical contact with the metal, and therefore cannot cause the electrochemical effects predicted by the mechanism given by Equations (1) through (3). To test this hypothesis, the progression of ennoblement of Type 316L SS colonized by two different biofilms was monitored; one was composed of a monoculture of *L. discophora* and the other was composed of a mixture containing *L. discophora* and two other microbial species (*Klebsiella pneumoniae* and *Pseudomonas fluorescens*), which do not oxidize manganese. Fluorescent in-situ hybridization (FISH) was used to distinguish the different microorganisms, their distribution, and their location with respect to a glass surface and speculate how such a distribution, on a SS surface, influences ennoblement of that surface.

## MATERIALS AND METHODS

### *Organisms and Culture Medium*

*L. discophora* American Type Culture Collection (ATCC) 51138, *K. pneumoniae* ATCC 700831, and *P. fluorescens* ATCC 700829 were revived from  $-70^\circ\text{C}$  in 1917 MSPV consisting of 0.24 g/L ammonium sulfate ( $(\text{NH}_4)_2\text{SO}_4$ ), 0.06 g/L magnesium sulfate ( $\text{MgSO}_4 \cdot 7\text{H}_2\text{O}$ ), 0.06 g/L calcium chloride

<sup>(1)</sup> UNS numbers are listed in *Metals and Alloys in the Unified Numbering System*, published by the Society of Automotive Engineers (SAE International) and cosponsored by ASTM International.

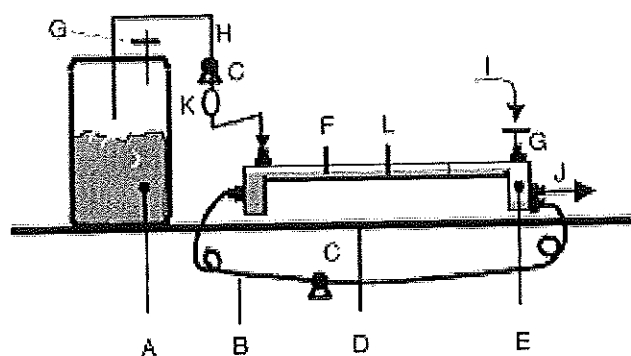

FIGURE 1. Schematic view of the experimental setup of the flat-plate reactor according to Jackson, et al.<sup>23</sup> (A) growth medium, (B) recycle loop, (C) peristaltic pump, (D) level work bench, (E) flat-plate reactor, (F) SCE, (G) air filter, (H) feed line, (I) air in, (J) outflow, (K) flow breaker, and (L) SS coupon holder. Glass microscope slides were placed on the bottom of the reactor to analyze the biofilm.

(CaCl<sub>2</sub>·2H<sub>2</sub>O), 0.02 g/L potassium phosphate (KH<sub>2</sub>PO<sub>4</sub>), 0.05 g/L sodium phosphate (Na<sub>2</sub>HPO<sub>4</sub>·7H<sub>2</sub>O), 2.383 g/L HEPES, and 1.0 mL 10 mM ferrous sulfate (FeSO<sub>4</sub>) (0.278 g FeSO<sub>4</sub>·7H<sub>2</sub>O in 100 mL distilled water) in 1.0 L deionized water. Resuscitated cultures then were cultivated on 1917 MSPV media as described above with a modification involving the reduction of HEPES buffer from 2.383 g/L to 1.21 g/L. The pH of the culture medium was adjusted to 7.2 with sodium hydroxide (NaOH) prior to autoclave sterilization. Following sterilization, the medium was cooled to 50°C, and 1 mL of vitamin solution [20.0 mg/L biotin [C<sub>10</sub>H<sub>16</sub>N<sub>2</sub>O<sub>3</sub>S], 20.0 mg/L folic acid [C<sub>19</sub>H<sub>19</sub>N<sub>7</sub>O<sub>6</sub>], 50.0 mg/L thiamine hydrochloride [C<sub>12</sub>H<sub>18</sub>Cl<sub>2</sub>N<sub>4</sub>OS], 50.0 mg/L D-(+)-calcium pantothenate [C<sub>18</sub>H<sub>32</sub>CaN<sub>2</sub>O<sub>16</sub>], 1.0 mg/L vitamin B12 [C<sub>63</sub>H<sub>88</sub>CoN<sub>14</sub>O<sub>14</sub>P], 50.0 mg/L riboflavin [C<sub>17</sub>H<sub>20</sub>N<sub>4</sub>O<sub>6</sub>], 50.0 mg/L nicotinic acid [C<sub>6</sub>H<sub>5</sub>NO<sub>2</sub>], 100.0 mg/L pyridoxine hydrochloride [C<sub>8</sub>H<sub>11</sub>NO<sub>3</sub>·HCl], 50.0 mg P-aminobenzoic acid [C<sub>7</sub>H<sub>7</sub>O<sub>2</sub>N], 1,000 mL filter-sterilized distilled water), and 1 mL of 20% pyruvate solution (0.4 g sodium pyruvate [C<sub>3</sub>H<sub>3</sub>NaO<sub>3</sub>], 100.0 mL filter-sterilized distilled water) and 4 mL of a 50-mM manganese sulfate solution (0.85 g MnSO<sub>4</sub>·H<sub>2</sub>O, 100 mL filter-sterilized distilled water) were added aseptically by using a 0.2-μm syringe filter (no. 431219, Corning Inc.<sup>1</sup>). Solid medium for bacterial enumeration was prepared as above with the addition of 15 g of noble agar (Difco<sup>1</sup>) prior to autoclaving.

#### Enumeration of Suspended Bacterial Populations Used as Inocula for Flat-Plate Reactors

Bacteria suspended in the bulk aqueous phase of the different reactors were enumerated by first homogenizing a sample followed by serial dilution

<sup>1</sup> Trade name.

and plating on MSPV agar using the drop plate method. Homogenization was performed for 1 min using a Janke and Kunkel IKA Labortechnik T25<sup>1</sup> basic homogenizer with a 100-mm by 8-mm outside diameter (OD) tip. The homogenized samples were serially diluted and plated using the drop plate method onto MPV agar. The plates were incubated for 24 h to 48 h at room temperature before colonies were enumerated. Cell densities, based on colony forming units (CFU), were determined for flask cultures in mid-log phase.

#### Dissolved Manganese Concentrations

The dissolved Mn(II) concentrations in the reactors were measured by the formaldoxime method.<sup>3</sup> Reactor solution of 1.5 mL was removed from each reactor and filtered through a 0.2-μm-pore-size cellulose acetate filter to remove suspended solids. Mixed ammonia-formaldoxime reagent of 1.5 mL was added to 0.5 mL of each sample and incubated for 30 min. The sample absorbance at 450 nm was measured with a Shimadzu 2101PC<sup>1</sup> spectrophotometer. The spectrophotometer was calibrated with Mn(II) sulfate (Fisher Scientific<sup>1</sup>).

#### Flat-Plate Reactor Design and Operation for Evaluation of Distribution of *L. Discophora* in Biofilm Formed on Glass Slides

The flat-plate reactor was setup and operated with minor modifications according to Jackson, et al. (Figure 1).<sup>23</sup> The flat-plate, open-channel reactor was a polycarbonate channel, with measurements of 2.5 cm wide, 4.0 cm deep, and 34.5 cm long. The reactor had a working volume of 150 mL, including the volume in all of the tubing. The tubing for the growth media and the sterile deionized water was Masterflex<sup>1</sup> 6401-16 (Cole Parmer), while the recycle, air, and waste lines were all Masterflex<sup>1</sup> 6402-16 (Cole Parmer). Peristaltic pumps (Cole Parmer) were used to maintain nutrient flow and recycle rates. The air line had an in-line bacterial air vent filter (Pall-Gelman Laboratory) with a pore size of 1 μm. Prior to sterilization, glass microscope slides were placed in the bottom of the reactor as substrata for bacterial colonization and biofilm formation. Waterproof weather stripping was placed along the top edge of the reactor and the lid was secured in place with tie straps. The reactor was sterilized with a 20% Clorox<sup>1</sup> bleach solution for 2 h. Following sterilization, the reactor was flushed with 10 L of sterile deionized water (autoclaved at 121°C for 5 h). After flushing, the reactor was filled with 150 mL of media and allowed to circulate. The feed rate was 0.4 mL/min. The reactor was continuously aerated using compressed air at 3 L/h. The reactor was run for 5 days without any inoculation to evaluate the sterility of the reactor. A 10-mL sample of this media was withdrawn aseptically, homogenized, and plated as previously de-

TABLE 1  
Elemental Composition of Type 316L SS Coupons<sup>(A)</sup>

Composition (wt%)									
C	Cr	Cu	Fe	Mn	Mo	Ni	P	S	Si
0.020	17.01	—	Bal	1.71	2.12	11.08	0.035	0.002	0.060

<sup>(A)</sup> Provided by vendor, Metal Samples, Inc.

scribed to evaluate the sterility of the bulk aqueous phase in the reactor.

### Flat-Plate Reactor Inoculation

A flat-plate, open-channel reactor was inoculated with 15 mL of a mid log phase culture of *L. discophora* prepared as described above. Another flat-plate reactor for the multispecies biofilm was inoculated aseptically with 15 mL of mid log phase culture of *K. pneumoniae* and *P. fluorescens* and 15 mL of mid log phase culture of *L. discophora* using a needle and syringe to introduce each culture inoculum into the sterile culture medium feed line of the reactor. Following are the approximate cell density values of the inoculum:  $2.09 \times 10^8$  cells/mL for *K. pneumoniae*,  $2.29 \times 10^8$  cells/mL for *P. fluorescens*, and  $1.22 \times 10^7$  cells/mL for *L. discophora*, as determined by the plating procedure previously described. During the inoculation, the flow of growth media, the recycle loop, and the airflow were stopped and the waste line was clamped. Approximately 1 h after the inoculation, the recycling was resumed and continued for 24 h before the feed pump was turned on. Also at that point, the airflow was restored to the reactor, the effluent clamp was removed, and reactor continued to operate as described by Jackson, et al.<sup>23</sup>

### Evaluation of Biofilm Ennoblement

The approach of Dickinson, et al.,<sup>9</sup> using Type 316L SS coupons were used to monitor ennoblement. Type 316L SS coupons (1.6 cm diameter; Metal Samples, Inc.) were used as substrata for bacterial colonization and biofilm formation. Elemental composition of the coupons is given in Table 1. Before introduction to the reactor, the SS coupons were abraded with wet 600-grit silicon carbide (SiC) paper, rinsed and sonicated in distilled water, rinsed with 95% ethanol (C<sub>2</sub>H<sub>5</sub>OH), air dried according to Dickinson, et al.,<sup>9</sup> then epoxy embedded in a hollow polycarbonate tube (1.9 cm diameter by 10 cm). Coupons were visually inspected for crevice corrosion. The coupons were inserted through the cover of the previously described flat-plate reactor until the SS coupon was fully submerged in the flow of the media, and electrical connection was made to the coupons by fixing conductive copper tape to the unexposed side (Figure 1). The chloride concentration within the media solution was 0 ppm. The exposed coupon is face downward to prevent suspended solids from set-

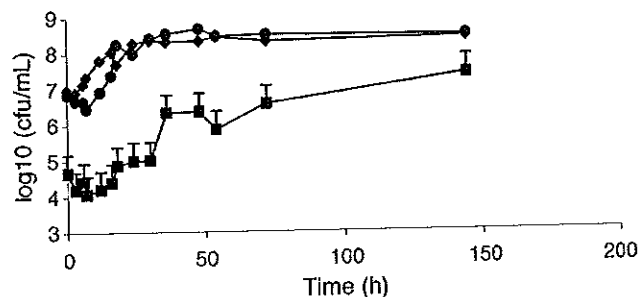

FIGURE 2. Cell densities in biofilm: (■) *L. discophora*, (◆) *K. pneumoniae*, and (●) *P. fluorescens*.

ting onto the surface. A SCE was mounted through the top cover and sealed with rubber washers and silicon. The potential was read with a multimeter (Wavetek Corp.).

### Oligonucleotide Probe Design

The oligonucleotide probes used in this study were universal probe, Fz-1, negative strand probe (negative control), Fz-2, and *L. discophora* SP-6 specific probe, Psp-6, supplied by Integrated DNA Technologies. All probes were labeled at the 5' end with Oregon Green 488<sup>†</sup>. Base sequence for nucleotide probes are as follows, with corresponding positions in *E. coli* 16s rRNA sequence: Fz-1, 5'-og 488-gWATTACCgCGGcKgCTC-518;<sup>24</sup> Fz-2, 5'-og 488-gTgCCAgCMgCCgCgg-3';<sup>24</sup> Psp-6, 5'-og 488-ggCTATCCCCACTACTg-138.<sup>25</sup>

### Fluorescent In Situ Hybridization (FISH)

FISH was performed on mid log phase suspended cultures of *L. discophora* (36 h to 40 h), *K. pneumoniae* (18 h to 22 h), and *P. fluorescens* (18 h to 22 h) used as inocula for the flat-plate reactors (Figure 2). The cultures were chilled on ice and fixed for a minimum of 15 min by the addition of 0.1 volume of formalin (37% formaldehyde [HCHO] solution containing 10% to 15% methanol [CH<sub>3</sub>OH]).<sup>25</sup> Fixed samples then were centrifuged, and the pellet was washed twice with an equal volume of phosphate-buffered saline (PBS), which contained 130 mM sodium chloride (NaCl) and 10 mM sodium phosphate buffer, pH 7.2. Pellets were resuspended in enough PBS to yield a slightly turbid solution. Cell smears were made by spotting 10  $\mu$ L of fixed sample on gelatin-coated glass slides treated with chromate<sup>26</sup> and

allowed to air dry. The slides then were flooded with a 90:10 ethanol:formaldehyde solution for 1 min to permeabilize the cells, and washed according to Braun-Howland, et al.<sup>27</sup> Slides then were rinsed briefly with sterilized deionized water and allowed to air dry a final time. Hybridization followed the optimized protocol established by Siering and Ghiorse.<sup>25</sup> The fixed smears were washed with SET buffer.<sup>24</sup> The smears then were counterstained with 4 µg/mL propidium iodide (C<sub>27</sub>H<sub>34</sub>I<sub>2</sub>N<sub>4</sub>) and excess stain removed by rinsing with sterile water. A mounting medium (6 mL glycerol [C<sub>3</sub>H<sub>8</sub>O<sub>3</sub>]; 6 mL of 0.5 M bicarbonate buffer pH 8.6 containing 0.1 M sodium azide [N<sub>3</sub>Na; final concentration]) was applied to the smear to decrease fading of oligonucleotide fluorescence during microscopy.

FISH was performed on biofilms using a similar approach as that described above for suspended populations except that the fixation time was extended to 2 h to 4 h. Five-day biofilms were washed two times each for 3 min in a beaker containing sterile deionized water to remove fixing solution. Excess water was wicked away by touching the edge of the slide to a paper towel. After fixation, biofilm samples were embedded in OCT media 4583<sup>†</sup> (Tissue-Tek, Sakura Finetek) and frozen on a block of dry ice. Embedded biofilm was lifted off the substratum by gently twisting the slide. Sections of biofilm, 10 µm thick, were cut at an angle perpendicular to the glass surface using a Leica CM 1800<sup>†</sup> cryostat at -20°C. Perpendicular slices were collected on gelatin-coated slides treated with chromate.<sup>26</sup>

Hybridization of biofilm samples followed the protocol used for suspended cell populations except that incubation conditions and cell preparations were optimized for the biofilm population. Gelatin-coated slides with a biofilm cryosection were dehydrated with an ethanol:formaldehyde solution (90:10 volume:volume) and allowed to air dry. All slides received the same treatment, incubations and washes. One slide was used as a second negative control that did not receive probe but was treated with the hybridization solution, while the remaining three slides received 10 µg/mL final dilution of one of the three probes used in the study each by flooding the slide with hybridization solution and probe. Incubations were performed for a minimum of 8 h at 46°C. Cell preparations were washed with ice-cold 5x SET buffer for 1 min, followed by two washes using 1x SET buffer for 5 min at 48°C. No 0.2x SET washes were performed. The biofilm samples then were counterstained with 4 µg/mL propidium iodide and excess stain was removed by rinsing with sterile water. A mounting media was applied to the smear to decrease fading of oligonucleotide fluorescence during microscopy. FISH efficiency was determined by comparing the number of cells in a field of view under the microscope that displayed fluorescence from

hybridization of the oligonucleotide probe with the number of cells that were counterstained by propidium iodide.

### Microscopy

All samples were examined on a Leica TCS NT<sup>†</sup> confocal laser scanning microscope equipped with a 488-nm wavelength argon laser and a 563-nm wavelength argon/krypton laser. Samples were viewed using a 40X-oil immersion objective lens and magnified 2X using confocal microscope software. Laser power was set for the 488 and 563 at 50% and 100%, respectively. Photomultiplier tube settings were 710 to 764 for the red level and 690 to 710 for the green level. The biofilm was imaged using Leica TCS NT<sup>†</sup> software scanning 1-µm-thick optical sections vertically through the 10-µm biofilm cryosection twice to reduce background noise. Images were stored on a host computer for further analysis. Biofilm images were reconstructed using Metamorph<sup>†</sup> software (Universal Imaging Corp.) and the 1-µm section image, taken at 4 µm, 5 µm, and 6 µm, of the 10-µm-thick vertical cryosection was saved for further pixel analysis. From visual analysis, image sections obtained at 1 µm to 3 µm and 7 µm to 10 µm depths of the 10-µm-thick cryosection consistently gave decreased fluorescence and were not used in this study. Pixel analysis of scanned image 4-µm, 5-µm, and 6-µm depths of the 10-µm-thick cryosection sample were performed from the top of the biofilm to the substratum in each image using Scion<sup>†</sup> imaging software (Scion Corp.). The threshold setting for all images was set at 62 after running a series of controls that established this value as one that allowed detection of the maximum number of cells after elimination of the background fluorescence. Pixels containing red objects stained by propidium iodide represent the area containing all the bacterial cells present in the image. Pixels containing green objects represent cells that reacted positively with *L. discophora*-specific or universal FISH probe. Probing efficiency of the universal probe for *P. fluorescens* and *K. pneumoniae* was determined from suspensions and biofilms of pure cultures of each of these organisms as a percentage of the number of green pixels divided by the number of red pixels in each image x100. Probing efficiency of the *L. discophora*-specific probe for suspended and biofilm cells of *L. discophora* were assessed in the same manner as the universal probe for the *K. pneumoniae* and *P. fluorescens* by comparing the number of red pixels vs green pixels.

### Oxygen Microelectrode

The oxygen microelectrode used was a Clarke<sup>†</sup>-type electrode with an internal silver/silver chloride (Ag/AgCl) half-cell reference and silicone polymer diffusion membrane. The microelectrodes were constructed following the procedure described by

Revsbech.<sup>28</sup> An HP 4140B<sup>†</sup> pA meter/direct current (DC) voltage source was used to apply the polarization potential (-0.8 V) and to measure the current. The microelectrodes were calibrated in water, aerated and deaerated using air and pure nitrogen. The current was typically in the range from 10 pA to 150 pA for the nitrogen-saturated water and 100 pA to 700 pA for air-saturated water. The dissolved oxygen concentrations were 0 mg/L in the nitrogen-saturated water and 6.8 mg/L to 7.8 mg/L, depending on temperature, in the air-saturated water. Two-point calibration was considered sufficient. The typical response time of the microelectrode was short, about one second, and we allowed for several seconds to stabilize the readout before accepting the result. Before the measurements, the microelectrode was attached to a micromanipulator (Narishige<sup>‡</sup>) equipped with a stepper motor, Oriel stepper motor 18503<sup>†</sup> (Stratford, CT), then manually positioned with the tip just above the biofilm surface, and then moved stepwise vertically through the biofilm while measuring oxygen concentration at the selected locations. The custom written software that was used to control the electrode movements was integrated with the data acquisition system. During the measurements, a Nikon Diaphot 300<sup>†</sup> inverted microscope was used to visualize the tip of the microelectrode in the biofilm. The results of oxygen measurements were stored in a file and then used to plot oxygen concentration versus distance, as oxygen concentration profiles across the biofilm. When needed, the thickness of the diffusive boundary layer was determined as the distance from the biofilm surface to the location in the bulk liquid where oxygen concentration had reached 90% of that measured in the bulk solution,<sup>29</sup> and determined from the oxygen concentration profiles.

## RESULTS

### Growth Analysis, Microbial Differentiation, and Type 316L SS Ennoblement

*K. pneumoniae* and *P. fluorescens* both grew on MSPV agar plates and did not precipitate the manganese present. When inoculated in a flat-plate reactor system with MSPV broth medium, these two organisms together successfully formed a biofilm without precipitating manganese (data not shown). The colony morphology and the oxidase test were used to differentiate *K. pneumoniae* and *P. fluorescens*. *K. pneumoniae* produced mucoid colonies that were oxidase negative. *P. fluorescens* produced a semi-transparent colony giving an oxidase positive reaction. *L. discophora* was differentiated by manganese precipitation, ammonia-formaldehyde test, and colony morphology. *L. discophora* produced colonies on MSPV plates with dark brown precipitate and fibrous edges. Manganese(II) was removed from the system as determined by the ammonia-formaldehyde

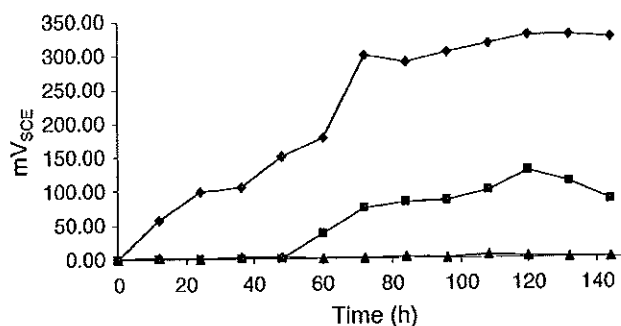

FIGURE 3. Microbial ennoblement of Type 316L SS coupon in a flat-plate reactor system: (■) three-species biofilm, (◆) *L. discophora* monospecies biofilm, and (▲) *K. pneumoniae* and *P. fluorescens* monospecies biofilms.  $E_{corr}$  of Type 316L SS was 300 mV<sub>SCE</sub>. *L. discophora* monospecies biofilm achieved a final  $E_{corr}$  of 323 mV<sub>SCE</sub>.

test, suggesting that the brown precipitate was manganese oxide.

Five-day-old biofilms of *L. discophora* ennobled Type 316L SS to 323 mV<sub>SCE</sub> (Figure 3). In contrast, the biofilms grown from the inoculation with *K. pneumoniae* and *P. fluorescens* caused no ennoblement of Type 316L SS, 0 mV<sub>SCE</sub> (Figure 3). The biofilms grown from the inoculation with all three populations produced partial ennoblement of the Type 316L SS, achieving a maximum potential of 143 mV<sub>SCE</sub> (Figure 3). Shortly after reaching a potential of 143 mV<sub>SCE</sub>, the potential dropped to 122 mV<sub>SCE</sub> (Figure 3).

### Fluorescent In Situ Hybridizations

The 16s rRNA universal oligonucleotide probe, Fz-1, reacted positively with suspended pure culture cells of *K. pneumoniae*, *P. fluorescens*, and *L. discophora* with an average hybridization efficiency of 73%, 78%, and 69%, respectively (Table 1). Negative control probe, Fz-2, had an average hybridization efficiency of <1% for each of the three populations of suspended pure culture cells (Table 1). *L. discophora*-specific probe Psp-6 hybridized to suspended pure culture populations of *K. pneumoniae*, *P. fluorescens*, and *L. discophora* with an efficiency of <1.00%, 1.24%, and 64.00%, respectively (Table 2).

Fixation, permeation, and hybridization conditions optimized for suspended populations were used to evaluate the abundance and distribution of the populations in biofilms growing on glass surfaces in the flow-through bioreactor. In a monospecies biofilm of *L. discophora*, Fz-1, Fz-2, and Psp-6 probes hybridized with efficiencies of  $50.31 \pm 6.80\%$ ,  $1.30 \pm 0.34\%$ , and  $53.00 \pm 6.26\%$ , respectively. Hybridization efficiency of the universal probe Fz-1 probe to all the cells in the three-species biofilm was  $51.50 \pm 7.65\%$ . Based on a survey of representative areas over the entire 100- $\mu$ m depth of the biofilm using FISH with the *L. discophora*-specific probe, a layer of *L. discophora* extended from the biofilm-bulk aque-

TABLE 2  
Hybridization Efficiency of All Oligonucleotide Probes Used in This Study

Probe	Organism	Threshold	Pixels Red	Pixels Green	% Hybridization	Average Hybridization
Control	<i>K. pneumoniae</i>	62	727.44	16.33	2.24	2.26
Control	<i>L. discophora</i>	62	1,298.33	58.78	4.53	
Control	<i>P. fluorescens</i>	62	292.67	0	0.00	
Fz-1	<i>K. pneumoniae</i>	62	1,467.33	1,048.56	71.46	72.69
Fz-1	<i>L. discophora</i>	62	2,817.89	1,933.89	68.63	
Fz-1	<i>P. fluorescens</i>	62	2,032.33	1,584.89	77.98	
Fz-2	<i>K. pneumoniae</i>	62	1,984.67	2.44	0.12	0.83
Fz-2	<i>L. discophora</i>	62	1,633.11	8.67	0.53	
Fz-2	<i>P. fluorescens</i>	62	1,845	33.78	1.83	
Psp-6	<i>K. pneumoniae</i>	62	1,255.33	7.89	0.63	64.39
Psp-6	<i>L. discophora</i>	62	1,313.89	846	64.39	
Psp-6	<i>P. fluorescens</i>	62	2,125	26.44	1.24	

ous phase interface to 40  $\mu\text{m}$  into the biofilm where approximately 78% of the organisms were located as determined by pixel analysis of total cells versus specific FISH probe for *L. discophora*. In this same three-species biofilm using the same analytical method, approximately 36.30% of the total *L. discophora* population resided in the top 20  $\mu\text{m}$  beneath the biofilm-bulk aqueous phase interface based on the same survey (Figures 4[a] and [b]). Furthermore, with pixel analysis, <1.00% of *L. discophora* population existed in the bottom 20  $\mu\text{m}$  of the biofilm proximal to the glass substrata.

In another representative 10- $\mu\text{m}$ -thick cryosection of a three-species biofilm grown on a glass substratum in a different flat-plate reactor, *L. discophora* comprised 30% of the total population of all bacteria present in the biofilm based on pixel analysis of representative areas over the entire 120- $\mu\text{m}$  depth of the biofilm using FISH with the *L. discophora*-specific probe. In this same biofilm near the biofilm-bulk aqueous phase, there did exist a dense layer of *L. discophora*, which comprised approximately 85% of the total *L. discophora* population as determined using FISH with the *L. discophora*-specific probe. This dense layer extended from the biofilm-bulk aqueous phase to a depth of 60  $\mu\text{m}$  (Figures 4[c] and [d]). Using the *L. discophora*-specific probe revealed that nearly 51% of the total *L. discophora* population was located at a depth between 20  $\mu\text{m}$  and 40  $\mu\text{m}$  from the biofilm-bulk aqueous phase. Less than 1% of the total *L. discophora* biofilm population was detected in the bottom 10  $\mu\text{m}$  of the biofilm as measured from the biofilm-bulk aqueous phase.

Suspended cell population fluorescent in situ hybridization indicated that probe Psp-6 was specific for *L. discophora*, and is in agreement with previously published literature. Siering and Ghiorse<sup>25</sup> demonstrated the specificity of this probe against other closely related organisms of which Psp-6 only hybridized to *L. discophora* SP-6. Visual observation of our

FISH results indicates that cells reacted with the probe. With pixel analysis, hybridization efficiencies ranged from 64% to 78%. Siering and Ghiorse<sup>25</sup> demonstrated that ribosomal abundance, rather than cell envelope permeability, is a major controlling factor affecting FISH results of proteobacteria. Hypothetically, our reduced hybridization efficiency results could be due to a low level of target rRNA in cells that were not in log phase growth. However, testing this hypothesis and further studies to determine the basis of the low recovery efficiency using FISH were beyond the scope of this work.

#### In Situ Oxygen Microgradients

In situ oxygen microgradients were evaluated in a biofilm composed entirely of *L. discophora* and in the three-species biofilm, both growing on a glass substratum. In *L. discophora* monospecies biofilm, oxygen microelectrode studies revealed oxygen concentrations of 4.35 mg/L and 3.85 mg/L at the biofilm-glass slide interface (Figures 5[a] and [b]). Furthermore, a light brown precipitate to dark brown precipitate was present on the biofilm sample as visualized through the diaphot dissecting microscope. However, in a different location within the same biofilm, the oxygen microelectrode revealed that oxygen was only able to penetrate approximately 325  $\mu\text{m}$  into the biofilm as measured from the biofilm-bulk aqueous solution phase. The anoxic region extended from 325  $\mu\text{m}$  from the biofilm-bulk aqueous solution phase to the bottom of the biofilm, the biofilm-glass slide interface, as determined with this same microelectrode (Figure 5[c]). At this location in the biofilm, the biofilm appeared very thick with thick dark brown precipitate as visualized through the diaphot dissecting microscope. After determining the diffusive boundary layer as previously stated, the depth of the biofilm was estimated to range between approximately 620  $\mu\text{m}$  and 800  $\mu\text{m}$ .

Four oxygen profiles also were taken in the three-species biofilm that developed on the glass cou-

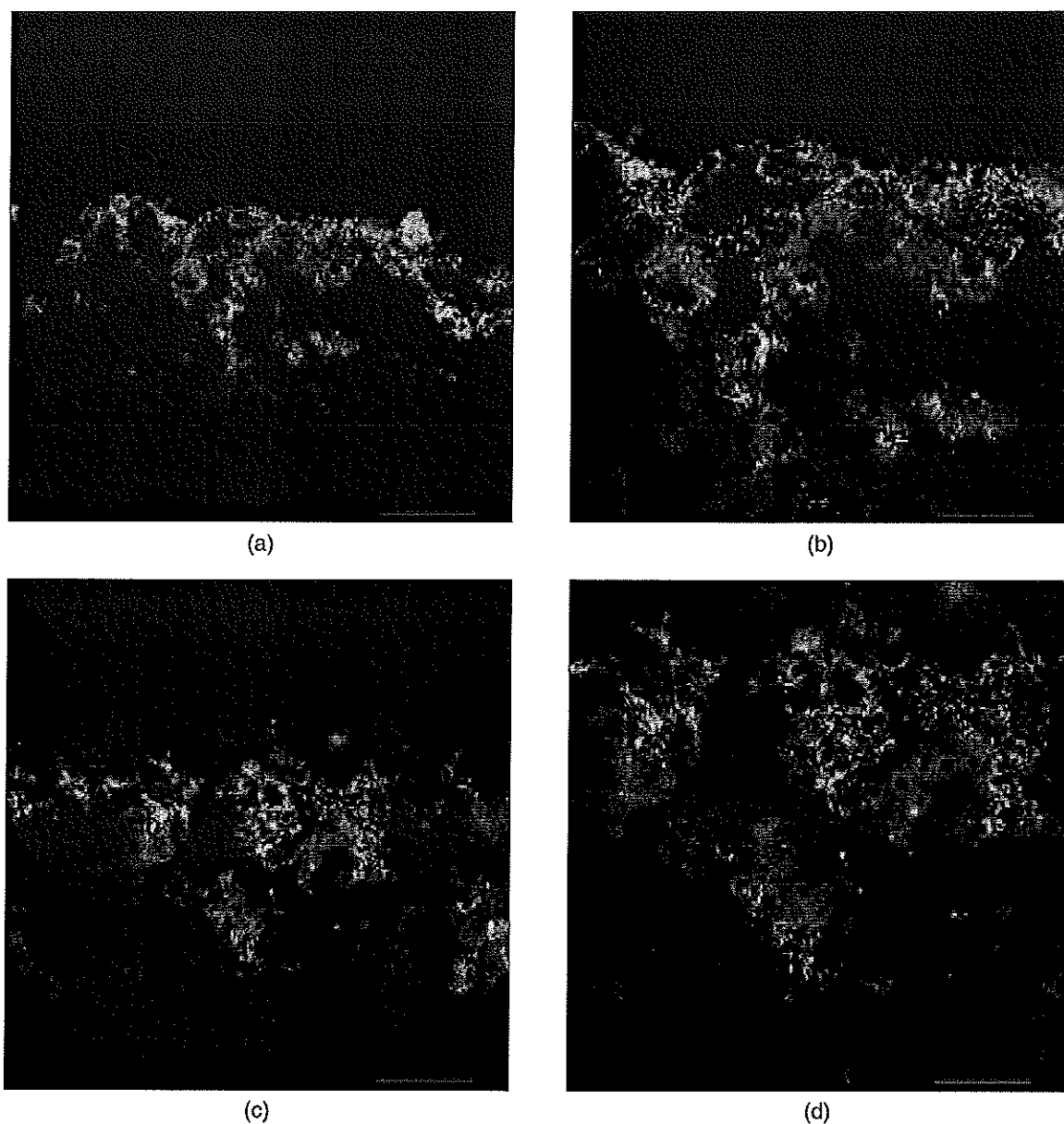

**FIGURE 4.** Fluorescent in situ hybridization of a cross section of a three-species biofilm on a glass coupon with *Psp-6 L. discophora*-specific probe. Red indicates counterstain with propidium iodide, and green is the FISH probe. Two biofilms are shown: (Images [a] and [c]) 40X magnification of biofilm, scale bar = 50  $\mu\text{m}$ . (Images [b] and [d]) 40X magnification with 2X zoom of biofilm, scale bar = 25  $\mu\text{m}$ .

pon in the other reactor. None of the oxygen profiles revealed oxygen at the biofilm-glass interface (Figure 6). The oxygen profiles were taken from locations that resembled the visual appearance and description as the previously described biofilm. Biofilm depth in the three-species biofilm ranged from approximately 580  $\mu\text{m}$  thick to 900  $\mu\text{m}$  as determined from the diffusive boundary layer. The thin biofilm area with light brown precipitate did not present an oxic zone at the substratum, as did the *L. discophora*-only biofilm. An interesting oxygen profile was revealed by the microelectrodes (Figure 6[d]). Oxygen concentra-

tions decreased as the microelectrode moved through the diffusive boundary layer and into the biofilm. At 40  $\mu\text{m}$  into the biofilm, as measured from the biofilm-bulk aqueous phase, the oxygen concentrations increased to 6.81 mg/L. This concentration of oxygen in the biofilm is almost equivalent to bulk phase oxygen concentrations, which was approximately 7.0 mg/L. This increase in oxygen concentration was maintained through the next 120  $\mu\text{m}$  of the biofilm. From a position 160  $\mu\text{m}$  from the biofilm-bulk aqueous phase, oxygen concentrations once again began to decrease to 0 mg/L, approximately

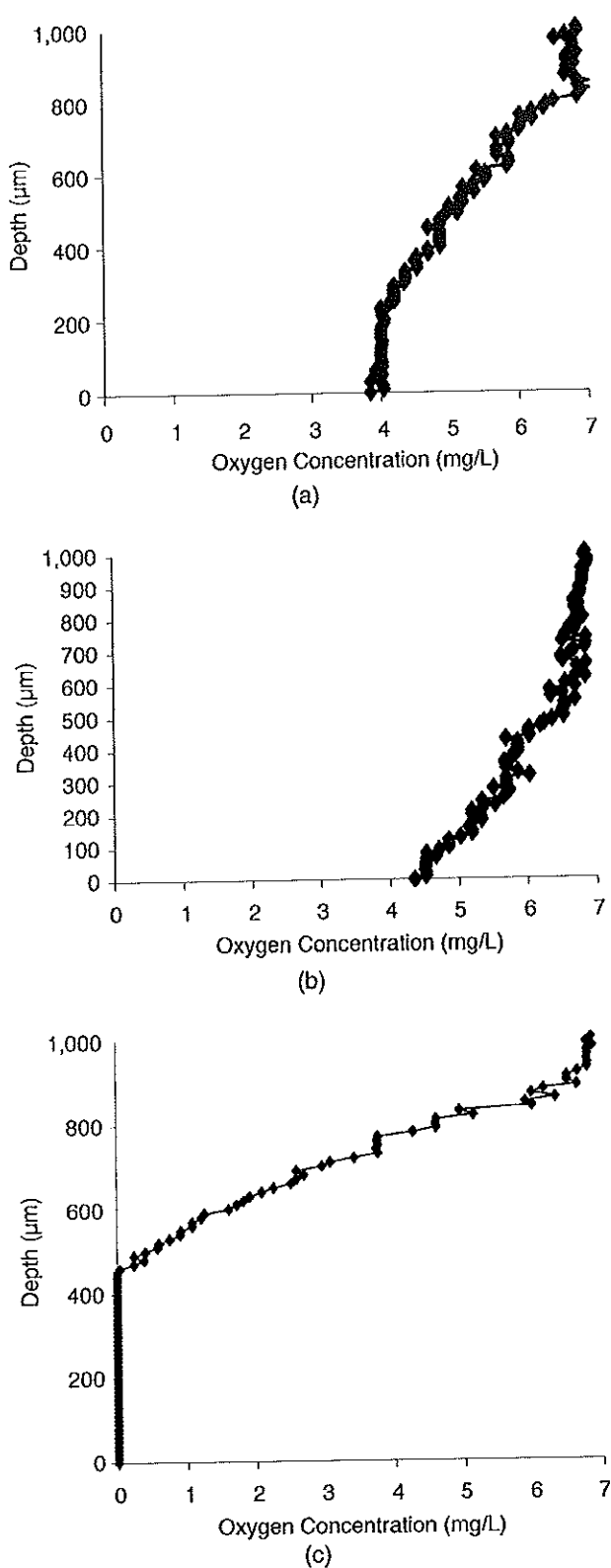

FIGURE 5. Microprofiles of oxygen in a *L. discophora* biofilm. Type 316L SS coupons were ennobled to 323 mV<sub>SCE</sub>: (a) and (b) profiles from film area demonstrating aerobic substratum; (c) profile from microcolony demonstrating anaerobic substratum as observed from dissecting. Profiles were measured at different points in the same biofilm.

220 μm from the biofilm-glass substrata interface. Although the Type 316L SS in this reactor was only partially ennobled by the biofilm, the heavy brown precipitate observed in the reactor and across the top of the biofilm suggested that manganese oxidation had occurred.

## DISCUSSION

FISH results revealed that the distribution of cells of the Mn-oxidizing bacterium *L. discophora* in a biofilm on a glass substratum is influenced by the presence of *K. pneumoniae* and *P. fluorescens*. The localization and homogeneous distribution of *L. discophora* in the top 40% of the three-species biofilm suggests that this bacterium competes successfully for resources in the bulk aqueous phase, but is not competitive with these other populations in deeper regions of the biofilm. Typically, *L. discophora* is found in aquatic habitats where there exist aerobic/anaerobic interface zones where Mn<sup>2+</sup> and Fe can be cycled between soluble and insoluble forms.<sup>11</sup> Concentration of *L. discophora* just above the oxic/anoxic boundary in the top 220 μm to 360 μm of the three-species biofilm is thus consistent with what has been observed in natural habitats.

The absence of cells of *L. discophora* in deeper regions of the biofilm may be due to the low levels of dissolved oxygen measured in this part of the three-species biofilm. The establishment of oxygen-depleted conditions that the biofilm-substratum interface in the three-species community also may have reduced any substratum-associated Mn oxides formed by *L. discophora* prior to establishment of anoxic conditions within the biofilm. Whereas, the substratum colonized by a monoculture of *L. discophora* accumulated Mn oxides formed by these bacteria, the substratum containing the three-species biofilms became depleted of Mn oxides.

The difference in behavior of the OCP for a SS surface containing biofilms of a monoculture of *L. discophora* and a SS surface containing the three-species biofilm likely reflected the stability of Mn oxides deposited at the surface by *L. discophora*. The structure of the biofilm formed by the monoculture of *L. discophora* permitted penetration of dissolved oxygen to the substratum, allowing the Mn oxides formed by *L. discophora* to remain stable, which favored establishment and maintenance of full ennoblement, which has been defined as an OCP of 350 mV<sub>SCE</sub> for Type 316L SS.<sup>4,9,30-32</sup> The reduction and dissolution of Mn oxides formed at the SS surface by *L. discophora* before oxygen was depleted is consistent with the observations of initial partial ennoblement of the surface followed by a decrease in OCP during development of the three-species biofilm. Furthermore, Dexter, et al.,<sup>33</sup> measured the presence of dissolved manganese near the surface of a metal

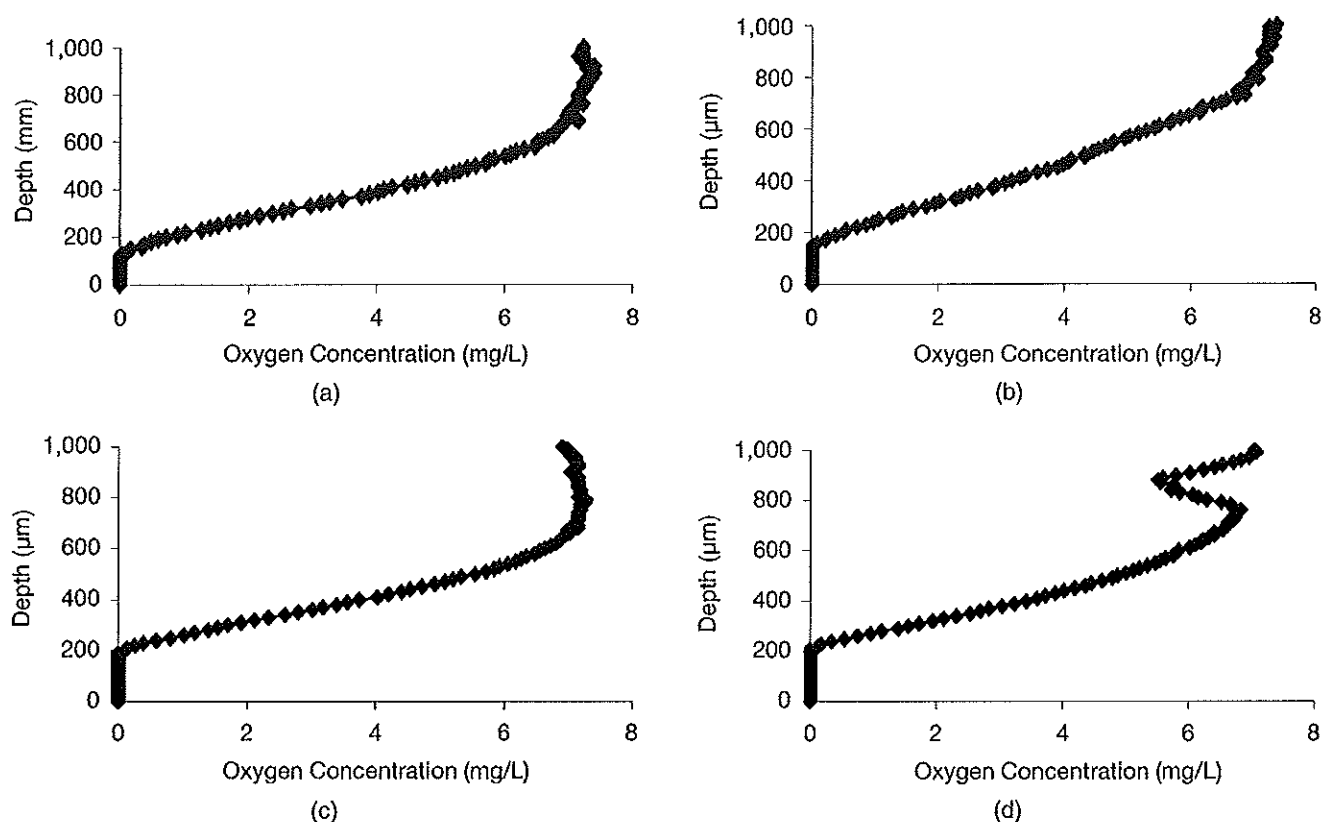

**FIGURE 6.** Microprofiles of oxygen in a consortium biofilm containing *L. discophora*. Type 316L SS coupons were only partially ennobled to 143 mV. All four profiles taken demonstrate an anaerobic substratum. Profiles were measured at different points in the same biofilm: (a) and (b) profiles from film area; (c) and (d) profiles from microcolony as observed from diashot microscope.

coupon in regions of a biofilm that was devoid of oxygen in the same location. It appears then that full ennoblement requires the Mn oxides to be in close proximity to the SS surface, since this condition was not achieved in the presence of the three-species biofilm even though Mn oxides were detected in upper layers of the biofilm distal from the metal substratum. The inability to achieve full ennoblement in the presence of manganese oxides in the present study is consistent with observations reported by Braughton, et al.,<sup>7</sup> in which the presence of manganese oxides in biofilms does not always cause ennoblement. These interpretations should be viewed with caution, since the distribution of *L. discophora* was determined in biofilms formed on a glass surface rather than in biofilms formed on a SS surface, and we do not yet know whether *L. discophora* distribution is the same on these different substrata.

## CONCLUSIONS

❖ It is suggested that in a multi-species biofilm, *L. discophora*, may compete successfully with other bacterial species during the initial colonization of the SS. During this time, *L. discophora* can oxidize and

precipitate manganese at the metal surface and promote ennoblement of the metal. However, the other faster-growing populations may displace *L. discophora* from the metal surface over time, leading to Mn-oxide reduction, solubilization, and displacement from the SS surface. This, in turn, reverses the ennoblement process initiated by *L. discophora*.

## ACKNOWLEDGMENTS

The research was supported by the United States Office of Naval Research, contract numbers N00014-99-1-0701 and N00014-02-1-0567, and by the cooperative agreement EED-8907039 between the National Science Foundation and Montana State University.

## REFERENCES

1. V. Scotto, R. DiCintio, G. Marcenaro, *Corros. Sci.* 25 (1985): p. 185-194.
2. B. Little, R. Ray, P. Wagner, Z. Lewandowski, W.C. Lee, W.G. Characklis, F. Mansfeld, *Biofouling* 3 (1991): p. 45-59.
3. A. Mollica, *Int. Biodeterior. Biodegr.* 29 (1992): p. 213-229.
4. S.C. Dexter, "Effect of Biofilms on Marine Corrosion of Passive Alloys," eds. C.C. Gaylarde, H.A. Videla, in *Bioextraction and Biodeterioration of Metals* (Cambridge U.K.: Cambridge University Press, 1995), p. 129-168.

5. W. Dickinson, F. Caccavo, Z. Lewandowski, *Corros. Sci.* 38 (1996): p. 1,407-1,422.
6. A. Lewandowski, W. Dickinson, W. Lee, *Water Sci. Technol.* 36 (1997): p. 295-302.
7. K. Braughton, R. Lafond, Z. Lewandowski, *Biofouling* 17 (2001): p. 241-251.
8. N. Yurt, R. Avci, Z. Lewandowski, J. Sears, "Passive Film Chemistry on 316L Stainless Steel Ennobled by Biomineralized Manganese," *CORROSION/2002* (Houston, TX: NACE International, 2002), p. 1-16.
9. W. Dickinson, F. Caccavo, B. Olesen, A. Lewandowski, *Appl. Environ. Microbiol.* 63 (1997): p. 2,502-2,506.
10. P. Linhardt, *Mater. Sci. Forum* 289-292 (1998): p. 1,267-1,274.
11. D. Emerson, W. Ghiorse, *Isolation, Appl. Environ. Microbiol.* 58 (1992): p. 4,001-4,010.
12. L. Adams, W. Ghiorse, *J. Bacteriol.* 169 (1987): p. 1,279-1,285.
13. P. Corstjens, J. de Vrind, T. Goosen, E. de Vrind-de Jong, *Geomicrobiol. J.* 14 (1997): p. 91-108.
14. T. Miyajima, *Arch. Microbiol.* 158 (1992): p. 100-106.
15. K. Nealson, B. Tebo, R. Rosson, *Adv. Appl. Microbiol.* 33 (1988): p. 279-318.
16. Y. Nelson, L. Lion, W. Ghiorse, M. Shuler, *Appl. Environ. Microbiol.* 65 (1999): p. 175-180.
17. H. Ehrlich, *Geomicrobiol. J.* 16 (1999): p. 153.
18. R. Amann, W. Ludwig, *FEMS Microbiol. Rev.* 24 (2000): p. 555-565.
19. S. Okabe, H. Satoh, Y. Watanabe, *Appl. Environ. Microbiol.* 65 (1999): p. 3,182-3,191.
20. C.M. Santegoeds, T.G. Ferdeman, G. Muyzer, D. de Beer, *Appl. Environ. Microbiol.* 64 (1998): p. 3,731-3,739.
21. A. Schramm, N. Revsbech, N. Ramsing, R. Amann, K. Schleifer, *Appl. Environ. Microbiol.* 62 (1996): p. 4,641-4,647.
22. A. Stone, *Geochim. Cosmochim. Acta* 51 (1987): p. 919-925.
23. G. Jackson, H. Beyenal, W. Rees, Z. Lewandowski, *J. Microbiol. Methods* 47 (2001): p. 1-10.
24. S. Giovannoni, G. Delong, G. Olson, N. Pace, *J. Bacteriol.* 170 (1988): p. 720-726.
25. P. Sterling, W. Ghiorse, *Appl. Environ. Microbiol.* 63 (1997): p. 644-651.
26. E. Delong, "Single-Cell Identification Using Fluorescently Labeled Ribosomal RNA-Specific Probes," in *Handbook of Methods in Aquatic Microbial Ecology*, eds. P. Kemp, B. Sherr, E. Sherr, J. Cole (Boca Raton, FL: Lewis Publisher, 1993), p. 285-294.
27. E. Braun-Howland, S. Danielsen, S. Nierzwicki-Bauer, *Biotechniques* 13 (1992): p. 928-933.
28. N. Revsbech, *Limnol. Oceanogr.* 34 (1989): p. 474-478.
29. B. Jorgensen, D. Des Mariats, *Limnol. Oceanogr.* 35 (1990): p. 1,343.
30. W. Dickinson, Z. Lewandowski, *Biofouling* 10 (1996): p. 79-93.
31. B.H. Olesen, R. Avci, Z. Lewandowski, "Ennoblement of Stainless Steel Studied by X-Ray Photoelectron Spectroscopy," *CORROSION/98*, paper no. 275 (Houston, TX: NACE, 1998).
32. S. Motoda, Y. Suzuki, T. Shinohara, S. Tsujikawa, *Corros. Sci.* 31 (1990): p. 515-520.
33. S. Dexter, K. Xu, G. Luther III, *Biofouling* 19 (2003): p. 139-149.

## COR•Lit & MP•Lit Indexes

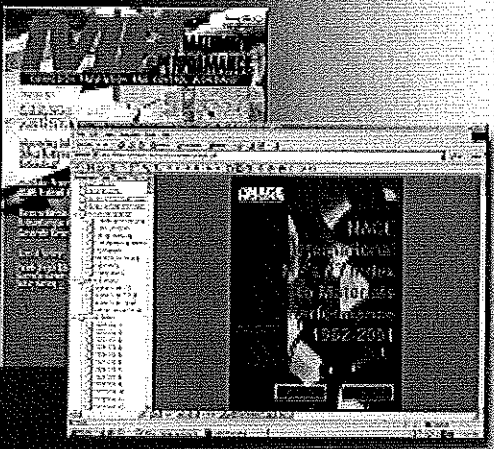
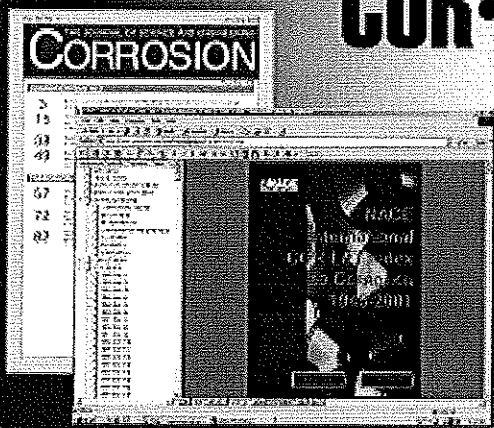

**Access the indexes for FREE on the Web at [www.nace.org](http://www.nace.org)**

Electronic indexes of articles in *CORROSION* (COR•Lit) and *Materials Performance* (MP•Lit) can save you time researching technical information. MP•Lit is an electronic index of all technical articles published in *MP* since 1964. COR•Lit covers all technical articles published in *CORROSION* since 1945. This easy-to-use search and retrieval system allows the user to search keywords or phrases and generate a list of citations. Each citation identifies the periodical in which the article originally appeared, the issue date, title of the article, author, and the first page number. (Please note: This product is not affiliated with any other organization or company.)

COR•Lit/MP•Lit Indexes are updated annually.

**NACE**  
INTERNATIONAL  
THE CORROSION SOCIETY