



A method of graphical analysis for unsymmetrical three-phase circuits  
by Armin John Hill

A THESIS Submitted to the Graduate Committee in partial fulfillment of the requirements for the degree of Master of Science in Electrical Engineering  
Montana State University  
© Copyright by Armin John Hill (1938)

**Abstract:**

This thesis presents a method of graphical analysis for electric circuits which is based upon some of the simple aspects of tensor analysis as recently applied in electrical problems\* A development of the method is made in such a manner as to be understandable by undergraduate engineering students. The relationship between the homogenous linear transformation used in teaser analysis, and the ordinary system of three simultaneous linear equations found in elementary analytic geometry is shown and the graphical representation of this transformation is used as a basis of the later developments# It becomes possible through such a presentation to solve a system of three simultaneous linear equations graphically\* by applying some principles of descriptive geometry® A brief development of the tensor notation is included in order that this notation can be used in the more complex developments of the later parts® The possibility of the study of electric circuits through graphical analysis based upon such a presentation is discussed briefly\* and a few of the fundamental methods of procedure for such an analysis are presented® An extension, of the principles to include equations with complex quantities, is made\* and these are applied to the study of alternating current circuits® General circuit problems in this form are found to be very complicated\* but most of the actual problems are simplified enough that they can be handled on a practicable basis® The method is found to be particularly useful in handling unbalanced three-phase systems\* either directly or by means of symmetrical components® With the latter\* the transformation to such components can be made by means of a chart which has the same form for all problems of this nature.

In the commonly occurring cases where the zero-phase components are absent\* this chart takes the form of a convenient slide rule\* on which the two remaining sets of components can be obtained from two settings of the slide# As with the tensor analysis which it parallels\* this method makes possible a simultaneous analysis of an entire network®. It also offers a graphical introduction to tensor methods for the student who has had a limited mathematical background® Extensions of the graphical method to other fields are indicated\* and it is hoped that such indications will lead to an increased application and interest in the valuable and important concepts given the engineer by tensor analysis®

11

A METHOD OF GRAPHICAL ANALYSIS FOR  
UNSYMMETRICAL THREE-PHASE CIRCUITS

A THESIS  
by  
Armin J. Hill

A METHOD OF GRAPHICAL ANALYSIS FOR UNSYMMETRICAL  
THREE-PHASE CIRCUITS

by

ARMIN J. HILL

A THESIS

Submitted to the Graduate Committee

in

partial fulfillment of the requirements

for the degree of

Master of Science in Electrical Engineering

at

Montana State College

Approved:

C. F. Bowman

In Charge of Major Work

C. F. Bowman

Chairman, Examining Committee

J. B. Johnson  
Chairman, Graduate Committee

Bozeman, Montana

June, 1938

N378  
H55m  
cup. 2

TABLE OF CONTENTS

	page
INTRODUCTION: - - - - -	6
PART I: SIMULTANEOUS LINEAR EQUATIONS WITH REAL VALUES ONLY - - - - -	12
Explicit and Implicit Forms - - - - -	12
Interpretation of the Equations as a Transformation of Coordinates - - - - -	13
The Unit Points - - - - -	15
Coefficients and Coordinates - - - - -	17
The Space Vector - - - - -	18
Graphical Interpretation - - - - -	18
Evaluation of the Explicit Variables - - - - -	19
Extension to Four and More Equations - - - - -	21
Evaluation of the Implicit Variables - - - - -	22
Solving the Equations Graphically - - - - -	22
Construction for Solution - - - - -	23
The Tensor Notation - - - - -	25
Applications to Problems - - - - -	30
Graphical Analysis - - - - -	34
Effect of Variation in one of the Implicit Coordinates - -	34
Effect of Variation in one of the Explicit Coordinates - -	36
Effect of Variation of the Coefficient Values - - - - -	36
PART II: APPLICATIONS TO PROBLEMS INVOLVING ALTERNATING CURRENTS -	39
Problems Involving Resistance Only - - - - -	39
The Problem when all Values are Complex - - - - -	42
Equations for a Two-Coil Transformer - - - - -	44

Ag 11 '38 of Graduate Committee

Table of Contents (Cont.)

	page
Extension to Three Coils - - - - -	45
Equations for Unbalanced Three-Phase Networks - - - - -	45
Solving Equations in the Complex Form - - - - -	47
Graphical Approximations - - - - -	48
Case I: Values of one Transformation Matrix Small - - -	48
Case II: Values of Both Matrices Approximately Equal - -	50
PART III: SYMMETRICAL COMPONENTS IN UNBALANCED THREE-PHASE CIRCUITS	54
Equations for Symmetrical Components - - - - -	54
Transformation Matrices for Symmetrical Components - - -	56
A Graphical Chart for Obtaining Symmetrical Components - - -	57
The Symmetrical Component Slide Rule - - - - -	59
Use of the Symmetrical Component Slide Rule - - - - -	60
Design and Limitations of the Slide Rule - - - - -	61
The Inverse Transformation - - - - -	62
Use of the Slide Rule for Inverse Transformations - - - - -	63
Analysis of Unbalanced Three-Phase Circuits - - - - -	65
PART IV: THE METHOD IN GENERAL - - - - -	66
Advantages - - - - -	66
Limitations - - - - -	68
Possible Value as an Introduction to Tensor Analysis - - - - -	70
Extended Applications - - - - -	72
References - - - - -	74
Bibliography - - - - -	76

LIST OF ILLUSTRATIONS

	page
Fig. 1 Unit Points and Axis System for Linear Transformation of Coordinates - - - - -	16
Fig. 2 Simultaneous Linear Equations Represented Graphically as a Transformation of Components of a Vector - - - - -	19
Fig. 3 Evaluation of Explicit Variables - - - - -	20
Fig. 4 Graphical Representation of Four Simultaneous Linear Equations - - - - -	22
Fig. 5 Graphical Solution of Simultaneous Linear Equations - - -	24
Fig. 6 Network for Problem 1. - - - - -	31
Fig. 7 Network for Problem 2. - - - - -	31
Fig. 8 Network for Problem 3. - - - - -	31
Fig. 9 Double Transformation - - - - -	33
Fig. 10 Effect on Position of P as Coordinate $I^3$ is Varied - - -	35
Fig. 11 Variation of Coordinate Values - Currents Held Constant -	37
Fig. 12 Evaluation of Explicit Variables - - - - -	41
Fig. 13 Solving Equations with Complex Variables - - - - -	41
Fig. 14 Evaluation of Explicit Variables - - - - -	43
Fig. 15 Transformation Axes for Two-Coil Transformer - - - - -	45
Fig. 16 Transformation for Unbalanced Three-Phase Circuits - - -	46
Fig. 17 Solving Three Simultaneous Equations by Successive Approximations - - - - -	49

List of Illustrations (Cont.)

	page
Fig. 18 Solution when the Two Matrices are Identical - - - - -	51
Fig. 19 Axes for Case II b) - - - - -	52
Fig. 20 Finding Symmetrical Components - - - - -	54
Fig. 21 Symmetrical Component Chart - - - - -	58
Fig. 22 Scales for Symmetrical Component Slide Rule - - - - -	60

# A METHOD OF GRAPHICAL ANALYSIS FOR UNBALANCED THREE-PHASE CIRCUITS

by  
Armin J. Hill

## Abstract

This thesis presents a method of graphical analysis for electric circuits which is based upon some of the simple aspects of tensor analysis as recently applied in electrical problems. A development of the method is made in such a manner as to be understandable by undergraduate engineering students. The relationship between the homogeneous linear transformation used in tensor analysis, and the ordinary system of three simultaneous linear equations found in elementary analytic geometry is shown, and the graphical representation of this transformation is used as a basis of the later developments. It becomes possible through such a presentation to solve a system of three simultaneous linear equations graphically, by applying some principles of descriptive geometry. A brief development of the tensor notation is included in order that this notation can be used in the more complex developments of the later parts. The possibility of the study of electric circuits through a graphical analysis based upon such a presentation is discussed briefly, and a few of the fundamental methods of procedure for such an analysis are presented.

An extension of the principles to include equations with complex quantities is made, and these are applied to the study of alternating current circuits. General circuit problems in this form are found to be very complicated, but most of the actual problems are simplified enough that they can be handled on a practicable basis. The method is found to be particularly useful in handling unbalanced three-phase systems, either directly or by means of symmetrical components. With the latter, the transformation to such components can be made by means of a chart which has the same form for all problems of this nature. In the commonly occurring cases where the zero-phase components are absent, this chart takes the form of a convenient slide rule, on which the two remaining sets of components can be obtained from two settings of the slide.

As with the tensor analysis which it parallels, this method makes possible a simultaneous analysis of an entire network. It also offers a graphical introduction to tensor methods for the student who has had a limited mathematical background. Extensions of the graphical method to other fields are indicated, and it is hoped that such indications will lead to an increased application and interest in the valuable and important concepts given the engineer by tensor analysis.

A METHOD OF GRAPHICAL ANALYSIS FOR UNSYMMETRICAL  
THREE-PHASE CIRCUITS

"The key to the simplest analysis of alternating currents lies in the use of graphical methods."<sup>1</sup> This statement made by Dr. Kennelly in 1898 has been well verified since that time for graphical methods have been widely developed and applied in practically every branch of electrical engineering. In fact, in most cases the graphical development has paralleled closely the application of the analytical mathematics, and often has proved so valuable that it has become the accepted method of procedure.

For instance, we find the concept of the time vector used by Steinmetz<sup>2</sup> as a pictorial representation of the complex number which had been so successfully introduced by Kennelly<sup>3</sup> and Steinmetz<sup>4</sup> to represent alternating current quantities. A study of the effect on such vectors of the changes which take place under certain operating conditions led to the discovery of the invaluable circle diagram<sup>5</sup> which since has come into general use in the analysis of the operating characteristics of alternating current machinery. Likewise charts and graphs proved themselves indispensable in the study of magnetic circuits when the corresponding mathematical equations were found to be too complicated for practical use. A survey of the field of power transmission reveals numerous applications of graphical procedures, some of which, such as the Mershon diagram<sup>6</sup>, and the Dwight<sup>7</sup>, and the Thomas<sup>8</sup> charts, have become standard equipment in the handling of many of the problems in this field. Similar applications are to be found in practically every branch of the electrical engineering field.

The development presented in this thesis is an attempt to give a graphical interpretation of a few of the simpler applications which have recently been made of tensor analysis in the study of electric circuits. "For many years the concepts introduced by vector analysis were sufficient for handling the types of electromagnetic phenomena encountered in electrical circuits and apparatus; but with the later increasing complexities involved in machine design, Steinmetz's complex numbers became inadequate for universal application."<sup>9</sup> Consequently, Gabriel Kron of the General Electric Company issued in 1932 a series of mimeographed articles dealing with the applications of tensor analysis to electrical machinery<sup>10</sup> and gave an informal paper on the subject before the winter convention of the AIEE in January, 1933.<sup>11</sup> This is apparently the first attempt at such an application in the field of electrical engineering, but almost immediately a widespread interest in this new tool was apparent, and many articles began to appear concerning various applications of tensor and matrix methods to electrical problems.<sup>12</sup> Kron revised and enlarged his original work, publishing it as a series of articles in the General Electric Review<sup>13</sup>, and in this form it is the most comprehensive treatment of the applications of tensor analysis to electric circuit problems found in available literature. It is primarily on some of the elementary parts of this work that the material of this thesis is based.

Tensor analysis, from the very beginning stages of its development demonstrated itself to be an extremely powerful and useful mathematical concept. It quickly proved its worth in the field of geometry, and the

demands of relativistic and quantum physics showed that its methods were capable of a wide variety of applications. Now these recent attempts to apply it to the type of problems with which engineers are primarily concerned have clearly shown that here at last is a tool, powerful and versatile enough to cope with the increasingly complex problems of the engineering field.

The rapidly increasing interest brought about by the success of these applications has made it imperative that engineers who wish to keep pace with present literature acquire a working knowledge of tensor principles. In fact, it is safe to predict that before long a thorough knowledge of tensor analysis will be an indispensable requisite of the well trained engineer. Up to the present time, however, such an understanding is the special privilege of the few who have had an opportunity to study a considerable amount of advanced mathematics. Now it has been found that many of the applications presented in this thesis can be based directly upon the mathematical forms encountered in elementary algebra and analytic geometry, and therefore should be within the grasp of the undergraduate engineering student, or of the engineer whose mathematical background is limited. For this reason care has been taken to present the material in such a way that it can be understood by one who has had no more than the equivalent of one year of college mathematics. It is hoped that in this way, such a presentation may help to bring about a more general understanding of this powerful mathematical concept.

Therefore, while the primary purpose of this thesis is to present a graphical parallel of the application of tensor analysis to electric circuits, insofar as physical limitations will permit, it is also hoped that the form of presentation will accomplish two other results. First, the graphical presentation offers an excellent introduction to tensor methods. One of the chief obstacles in the path of a general understanding of tensors is the difficulty of obtaining a clear mental picture of the concepts involved.<sup>14</sup> Since some of the more elementary of these are here developed graphically, and are thus given a physical interpretation, it is hoped this will provide a ground work of such a nature that the mental hazards of the more advanced concepts are materially reduced. In the second place, when such an approach is made, the close connection between the simpler aspects of tensor analysis and the forms encountered in algebra and in analytic geometry is stressed.

With these points in mind, care has been taken to develop the material from the standpoint of one not acquainted with tensor methods. Ordinary algebraic notation is used for the first developments, with the tensor notation introduced for handling the more complex applications. Also an attempt is made at all times to keep the close connection between the graphical, the algebraic, and the tensor concepts in mind. For instance a system of simultaneous linear equations is shown graphically as a transformation from one set of coordinates to another, and this in turn is shown to be the equivalent of a fundamental transformation used in tensor analysis.

As might be expected, since it is based upon a different form of mathematics, the graphical analysis presented here has little in common with methods now in accepted use. Many more or less successful methods of graphical analysis for electric circuits have been developed, among which may be mentioned the one by Eddy<sup>15</sup>, which is particularly applicable to variable frequency circuits, those presented by Lee<sup>16</sup>, which give the effect of the variation of any circuit constant upon the other circuit values, and a recently developed method of handling graphically impedances in parallel, given by Boening,<sup>17</sup> However, all of these are based upon the equations for a single electric circuit, or portion of a circuit. As with the corresponding mathematics, the circuit constants are inextricably mixed with the values impressed upon the circuit, with the result that for each new condition a new equation must be set up, and likewise a new graphical plot must be made.

The strength of the tensor method lies in the fact that all the conditions within a complex machine or network can be represented by a single equation<sup>18</sup>, and this equation not only is unchanged in form when a change takes place within the circuit, but it is similar in form for similar problems involving different networks or machines. Likewise the graphical application sets up a space structure which is useful in the analysis of all problems of a certain type. Variation of individual quantities within a given problem can be studied directly as a shift in the position of certain lines or points, in most cases not affecting many of the other values, and in no case affecting the general form of the problem. Further, within certain physical limitations, this method allows an analysis of an entire

network at one time, a feature which could not be expected of a method based upon the mathematics of a single circuit only.

Applications in this thesis will be confined to the analysis of electric circuits only, though the same principles may easily be applied to other types of electrical problems as well as to problems in other fields of engineering where the corresponding tensor transformations are applicable. Steady state conditions only have been considered, though again there seems to be a possibility of an extension to cover some types of transient conditions. Extensions have been made to include complex quantities, however, making possible a study of alternating currents.

The most complete analyses are possible when not more than three independent equations are involved. Therefore the method is particularly adapted to a study of three-phase systems. When the principles are applied in obtaining the symmetrical components of an unbalanced three-phase system, immediate success is apparent for it becomes possible to construct a chart from which these components can be read easily, and in the commonly occurring case where the zero-phase components are absent, this chart takes the form of a very convenient slide-rule.

No attempt is made here to cover the field thoroughly or to exhaust the possibilities of any particular branch, as the subject appears too broad to permit more than a preliminary survey. Some of the possibilities are pointed out, however, and it is hoped that enough material is presented to give an incentive for a more complete study of this apparently useful method of presentation.

PART I: SIMULTANEOUS LINEAR EQUATIONS WITH REAL VALUES ONLY

Explicit and Implicit Forms:

Let us begin by considering a system of three simultaneous linear equations:

$$\begin{aligned} a_1x + b_1y + c_1z &= k_1 \\ a_2x + b_2y + c_2z &= k_2 \\ a_3x + b_3y + c_3z &= k_3 \end{aligned} \tag{1}$$

where the a's, b's, and c's are constant real numbers. The values of x, y, and z which will satisfy these equations may be found by using determinants as follows:

Let D represent the determinant of the a, b, and c values, and define  $r_1$  as the minor of  $a_1$  in D,  $r_2$  as the minor of  $a_2$ , etc., with s and t to represent the minors of the b and c numbers respectively, with the added assumption that the symbol include not only the minor, but also the proper plus or minus sign according to the position of the respective a, b, or c value in the determinant D. Such minors with proper sign included are known as the "cofactors" of their respective a, b, or c number. Equations (1) may then be "solved" for x, y, and z in this form:

$$\begin{aligned} x &= \frac{k_1r_1 + k_2r_2 + k_3r_3}{D} \\ y &= \frac{k_1s_1 + k_2s_2 + k_3s_3}{D} \\ z &= \frac{k_1t_1 + k_2t_2 + k_3t_3}{D} \end{aligned} \tag{2}$$

These equations may now be put in a form similar to that of equations (1) by setting up a determinant of the coefficients which would be the "inverse transpose" of D. This is done by determining nine sets of values

(which we can represent by the letters d, e, and f) such that:

$$\begin{aligned}d_1 &= \frac{r_1}{D} & e_1 &= \frac{r_2}{D} & f_1 &= \frac{r_3}{D} \\d_2 &= \frac{s_1}{D} & e_2 &= \frac{s_2}{D} & f_2 &= \frac{s_3}{D} \\d_3 &= \frac{t_1}{D} & e_3 &= \frac{t_2}{D} & f_3 &= \frac{t_3}{D}\end{aligned} \tag{3}$$

giving us equations (2) in the form:

$$\begin{aligned}x &= d_1k_1 + e_1k_2 + f_1k_3 \\y &= d_2k_1 + e_2k_2 + f_2k_3 \\z &= d_3k_1 + e_3k_2 + f_3k_3\end{aligned} \tag{4}$$

Equations (1) and (4) are now in the same form, but we can see that the positions of the x, y, and z values and of the  $k_1$ ,  $k_2$ , and  $k_3$  values have been interchanged.

In order that no confusion may result in what follows, we will speak of the x, y, and z values as being in the "implicit" form when involved in the equations as they are in equations (1); and as being in the "explicit" form when in the positions they occupy in equations (4).

#### Interpretation of the Equations as a Transformation of Coordinates:

Select a system of coordinate linear axes in space and let the position of a point P with respect to them be defined by its coordinate distances, x, y, and z. Now determine another set of values, which may be called  $x'$ ,  $y'$ , and  $z'$ , in such a way that:

$$\begin{aligned}x' &= a_1x + b_1y + c_1z \\y' &= a_2x + b_2y + c_2z \\z' &= a_3x + b_3y + c_3z\end{aligned} \tag{5}$$

where the a's, b's, and c's are once again constant values, i.e. they are not in any way affected by the position of the point P.

Now think of the  $x'$ ,  $y'$ , and  $z'$  as representing values of the coordinates of P with respect to another set of axes,  $X'$ ,  $Y'$ , and  $Z'$  respectively. From equations (5) it will be seen that when the values of  $x$ ,  $y$ , and  $z$  are zero, the values of  $x'$ ,  $y'$ , and  $z'$  are also zero. Thus  $X'$ ,  $Y'$ , and  $Z'$  are coordinate axes having a common origin with the original set.

Equations (5) may therefore be said to represent a transformation of the coordinates of P from the original  $x$ ,  $y$ , and  $z$  values to the new  $x'$ ,  $y'$ , and  $z'$  values. In most of our applications it will be found more convenient to have  $x$ ,  $y$ , and  $z$  expressed explicitly, however, and this can be done by the method shown in the preceding section, this:

$$\begin{aligned}x &= d_1x' + e_1y' + f_1z' \\y &= d_2x' + e_2y' + f_2z' \\z &= d_3x' + e_3y' + f_3z'\end{aligned}\tag{6}$$

where the determinants of the d's, e's, and f's is the inverse transpose of that of the a's, b's, and c's as in equations (4).

From the similarity between equations (1) and (5), and between (4) and (6), it may be seen that any system of three simultaneous linear equations can be interpreted as a transformation, more specifically as a homogeneous transformation, from one system of coordinates to another. It will therefore be in order for us to examine this transformation in greater detail.

The Unit Points:

One of the first problems will be to determine the form of the second set of axes. This will involve first of all a location of the "unit points" on these axes, i.e. those points which will have as their  $x'$ ,  $y'$ , and  $z'$  coordinates  $(1,0,0)$ ,  $(0,1,0)$ , and  $(0,0,1)$  respectively.

Let us consider the first of these, the unit point on the  $X'$  axis with coordinates  $(1,0,0)$ . In order to locate this point with reference to the original set of axes, i.e. to find its  $x$ ,  $y$ , and  $z$  coordinates, it is merely necessary to substitute the given values of  $x'$ ,  $y'$ , and  $z'$  in equations (6). The three coordinates of the  $X'$  unit point are immediately seen to be  $(d_1, d_2, d_3)$ . Likewise the  $Y'$  unit point will be found to have the coordinates  $(e_1, e_2, e_3)$ , and the  $Z'$  unit point the coordinates  $(f_1, f_2, f_3)$ .

Let us now investigate the point with  $x'$ ,  $y'$ , and  $z'$  coordinates of  $(2,0,0)$ . By substituting as before, it will be seen that its coordinates in the original system are  $(2d_1, 2d_2, 2d_3)$ , or in other words, it is a point on a straight line through the origin and the  $X'$  unit point. More generally speaking, the point whose transformed coordinates are  $(x', 0, 0)$  will have coordinates in the original system of  $(x'd_1, x'd_2, x'd_3)$ ; and if the values of the  $d$ 's are constant, it can be seen that these points all fall on the same straight line. But these points are also on the  $X'$  axis, and if  $x'$  is allowed to take on all real values, all points on this axis will satisfy these conditions. In other words, the  $X'$  axis is a straight line.

Likewise it can be shown that the  $Y'$  and  $Z'$  axes are straight lines and we can make the general statement that if the coefficients in the

equations (5) or (6) are constants, both sets of axes are linear, and conversely, if all the axes are linear, the coefficients of the equations

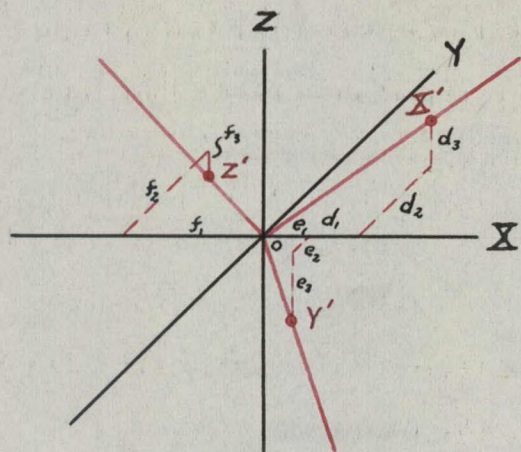

Fig. 1 Unit Points and Axis System for Linear Transformation of Coordinates

must have constant values. Therefore these equations may be said to represent a homogeneous linear transformation of coordinates.

A space representation of such a transformation is shown in fig. 1. A right hand system of axes in a rectangular Cartesian form is chosen for the original set for simplicity and convenience in plotting.

It may be remarked here that the discussion given above is perfectly general and that neither set of axes need be either rectangular or Cartesian in form. However, we usually have a choice in the form of one or the other of the sets, and throughout this thesis the original set will be given the rectangular Cartesian form. This choice should be made wherever possible for the added simplicity it gives.

The coordinate distances of the unit points representing the various coefficient values of the equations (6) are also indicated on fig. 1. It will be noticed that these are measured in the units of the original system in each case. Also, it may be noticed that the transformed axes are labelled at the unit points instead of at the positive end as is customary. For convenience the unit point and the axis will be given the same symbol here. As it is always apparent to which reference is made no confusion should result.

Danger of crowding and the relative unimportance of the unit points on the original Cartesian axes makes it impractical to apply this convention to them, and they will be labelled at their positive ends in the usual manner. Also to prevent too crowded a picture, the positive rays only of the transformed axes will be shown, and these axes will always be drawn in color. The  $X'$ ,  $Y'$ , and  $Z'$  symbols will always refer to the transformed system, and these axes may take any position as long as they are linear and the origin is common for both systems. Likewise  $X$ ,  $Y$ , and  $Z$  will always refer to the original rectangular Cartesian system. This notation will be used until the more convenient tensor notation is introduced.

#### Coefficients and Coordinates:

It will be seen from this analysis that the position of the unit points depends only upon the values of the coefficients in the equations of transformation. Thus, since all axes are linear, the relative positions of the two sets are definitely fixed by the values of these coefficients. These values may therefore be said to determine the transformation, and when arranged as a matrix or determinant will be known as the matrix or determinant, respectively, of the transformation. It is thus a very simple process to represent the coefficients in any system of two or three simultaneous linear equations as two sets of coordinate axes.

On the other hand it can be seen that the values of the coordinates,  $x$ ,  $y$ ,  $z$ , and  $x'$ ,  $y'$ ,  $z'$ , depend only upon the position of the point  $P$  and the form of the particular axis system referred to, not being involved in any way in the transformation from one system to the other.

### The Space-Vector:

It has already been noticed that the two systems of axes have a common origin. It may also be observed that the position of the point P with respect to this origin is not affected by the position of these axes. Let us now draw a space-vector OP, and it will be seen at once that the magnitude and direction of this vector is in no way dependent upon the system of axes selected. It is thus said to be "invariant" under any transformation of the type we have been discussing. In tensor analysis such invariant forms are of the utmost importance, for about them the whole scheme of analysis is built. This vector will therefore be of primary importance in this discussion for we will find that while it will always be referred to some system of axes, its properties are more fundamental than those of any such system, for it remains unchanged in any system that may be selected.

The coordinate values now take on a new meaning for they become the components of the space-vector parallel to their respective axes. Such a vector thus gives us a graphical representation of the relations between the two sets of coordinates, and since it is invariant it makes it immediately possible to find one of the sets, having given the other set and the equations of transformation.

### Graphical Interpretation:

We can thus represent three simultaneous linear equations as a homogeneous linear transformation of the component values of a space-vector, and can represent this transformation graphically as is done in fig. 8. It now becomes possible to give a graphical interpretation to each of the

component parts of equations (6). By selecting the two sets of axes as was done for fig. 1, the nine constant coefficient values become the three

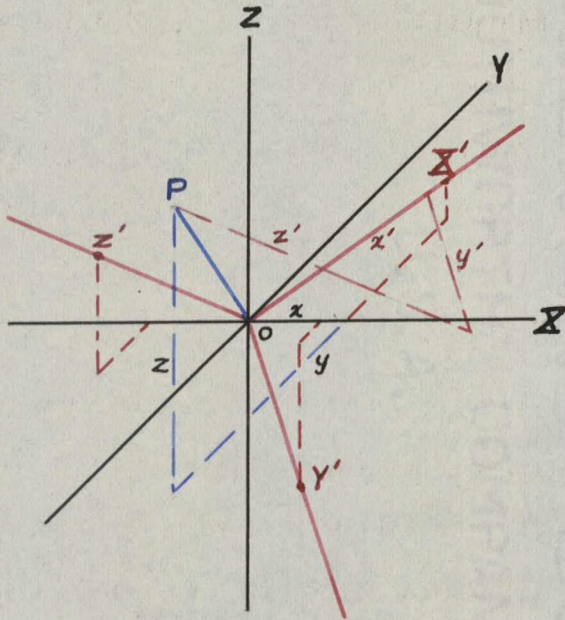

sets of coordinates of the three unit points,  $X'$ ,  $Y'$ , and  $Z'$ . The two sets of variable or coordinate values,  $x, y, z$ , and  $x', y', z'$ , became the two sets of three components each of the vector  $OP$  along their respective axes. Thus the fifteen component parts of equations (6) are represented by fifteen separate values in the graphical picture.

Fig. 2 Simultaneous Linear Equations Represented Graphically as a Transformation of Components of a Vector

Not only are the components of the equations kept separate, but of more importance is the fact that the

coefficient and the variable values are represented by two distinct types of configuration, for while the coefficient values determine the form of space structure which is to be used, the variable values represent the relationship of an invariant space-element to these reference forms.

Evaluation of the Explicit Variables:

Assuming that the transformation determinant is known and that the  $x'$ ,  $y'$ , and  $z'$  coordinates of the point  $P$  are given, it is a very simple matter to determine the values of  $x, y$ , and  $z$  graphically when these are expressed explicitly as in equations (6). If two equations only are involved, the

representation may be made on one plane. If three equations are given, it becomes necessary to have a space figure, and this is best shown for these

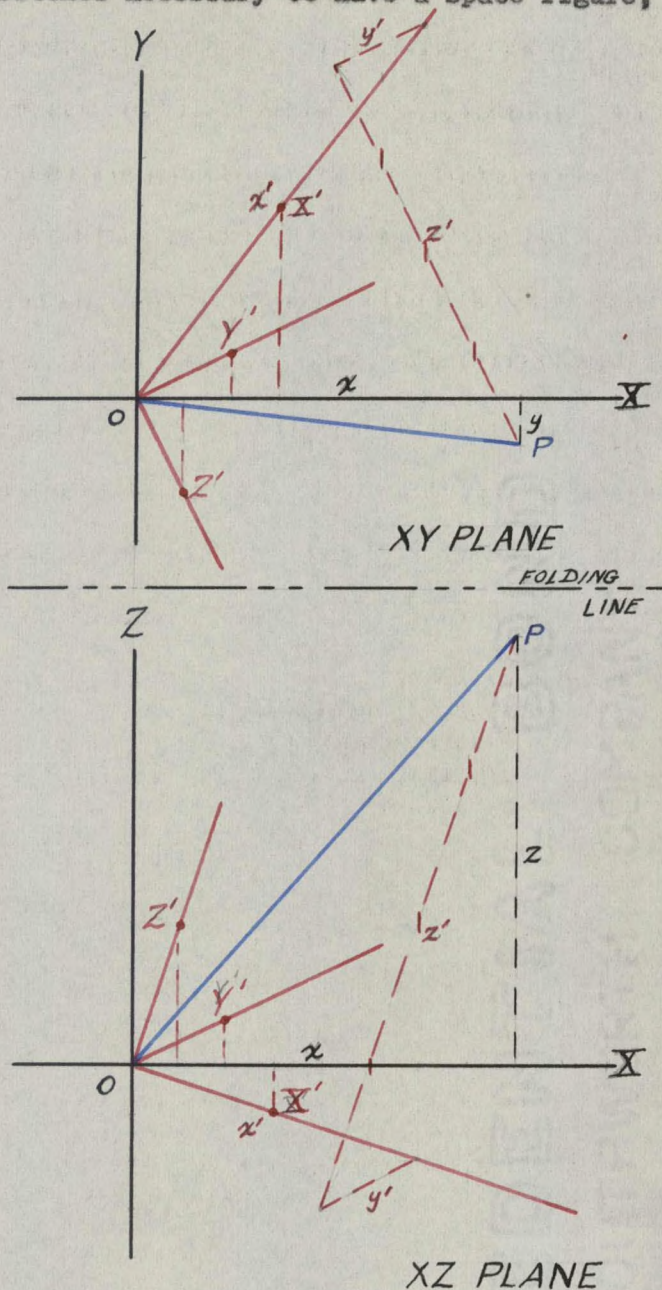

purposes on two projections as shown in fig. 3. A third quadrant projection of the right hand system of axes is used, which places the horizontal XY plane above the vertical XZ plane, and keeps the positive ends of the Y and Z axes upward, and of the X axis to the right.

Fig. 3 is a representation of a definite problem:

Given the equations:

$$\begin{aligned} x &= 3x' + 2y' + z' \\ y &= 4x' + y' - 2z' \\ z &= -x' + y' + 3z' \end{aligned} \quad (7)$$

Show the relationship between the two sets of axes, and evaluate  $x$ ,  $y$ , and  $z$  for given values of  $x'$ ,  $y'$ , and  $z'$ .

Fig. 3 Evaluation of Explicit Variables

The unit points,  $X'$ ,  $Y'$ , and  $Z'$ , will be respectively  $(3,4,-1)$ ,  $(2,1,1)$ , and  $(1,-2,3)$ . Plot these and through each in turn and the origin construct

the corresponding axis. Selecting some point P, located by its coordinates, say  $(2, -1, 4)$ , on the transformed axes, i.e. having given  $x'=2$ ,  $y'=-1$ ,  $z'=4$ , it will be found that the coordinates with respect to the original system can be obtained by taking twice each of the Cartesian components of  $X'$ , minus one of each component of  $Y'$ , plus four times each component of  $Z'$ , then adding algebraically all of the components parallel to each of the original axes. This would give the value of  $x$  as  $2 \cdot 3 + (-1) \cdot 2 + 4 \cdot 1$ , or 8, which is identical with the value which would be obtained by substituting the given values of  $x'$ ,  $y'$ , and  $z'$  in equations (7).

Graphically this process consists merely of reading off the rectangular Cartesian coordinates of the point P, once it has been located with reference to the transformed system. For instance in the problem given, the coordinates of P can be read from fig. 3 as  $(8, -1, 9)$  or this would mean  $x=8$ ,  $y=-1$ ,  $z=9$ , which check the values obtained by substitution. Thus if the transformation constants remain unchanged, the values of  $x$ ,  $y$ , and  $z$  for any set of values of  $x'$ ,  $y'$ , and  $z'$  can be read directly from a diagram such as fig. 3. It will be shown later that this apparently very simple procedure can be given some very useful applications.

#### Extension to Four and More Equations:

The method of using projection planes can easily be extended to cover the conditions which arise when four or more simultaneous equations are involved. Four equations, for example, will require four original and four transformed axes. No space figure of such an arrangement can be drawn in one view, of course, but by selecting projection planes properly, as shown

in fig. 4, it is possible to evaluate the explicit variables by the process just described.

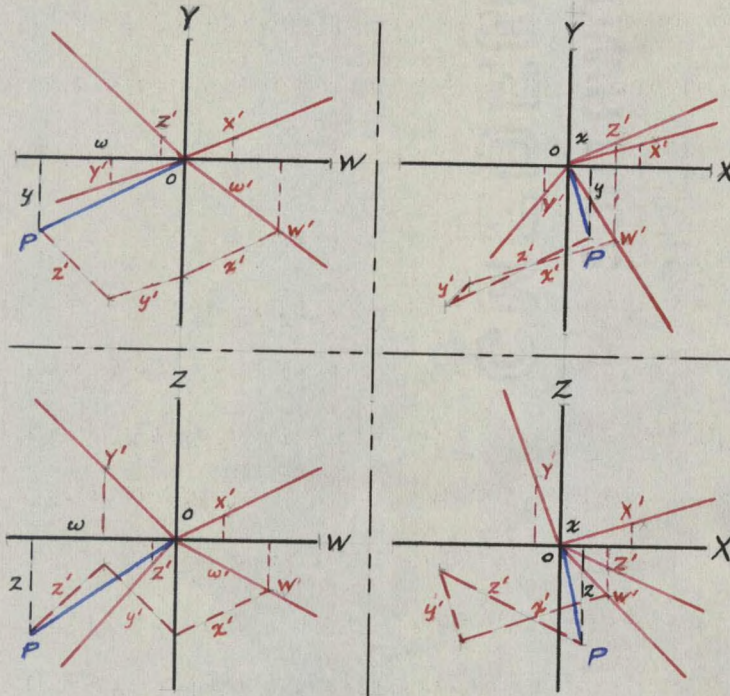

Fig. 4 Graphical Representation of Four Simultaneous Linear Equations

Let the four rectangular Cartesian axes be represented by  $W, X, Y,$  and  $Z,$  and the transformed axes by  $W', X', Y',$  and  $Z'.$  The point  $P$  will now be located by means of its four coordinate values  $w', x', y',$  and  $z',$  and the explicit values can be read off as the  $w, x, y,$  and  $z$  coordinates of this point.

It will be noticed that the fourth plane is used only for a check, as any three planes will give the desired information. Extensions can be made to any number of equations by adding another plane for each added equation.

Evaluation of the Implicit Variables - Solving the Equations:

Since the space vector fixes the relationship between the two sets of coordinate values, it should be possible, having one set and the transformation given, to determine the other set, whether this set is in the explicit or in the implicit form. It will now be shown that it is possible to evaluate the implicit variables, in short to solve two or three simultaneous linear equations, by a simple modification of these same graphical methods.

We will now have given the values of the  $x$ ,  $y$ , and  $z$  in equations (6), or in other words the rectangular coordinates of the point  $P$  will be known. The problem now becomes one of determining the components of the vector  $OP$  parallel to each of the transformed axes when these axes may make any angle with each other, or with the original set. This can be done quite easily in a plane when only two equations are involved, but in order to find these components in three dimensions it is necessary to project the figure onto a third plane which will be perpendicular to the plane of two of the transformed axes. This may be done by applying the principles of orthogonal projection as found in any elementary text on descriptive geometry. For convenience the construction is shown in fig. 5, and is described here.

#### Construction for Graphical Solution of Three Equations; 19

From the transformation equations construct the two sets of axes as was done for fig. 1, again keeping  $X$ ,  $Y$ , and  $Z$  orthogonal and Cartesian. Use two planes as in fig. 3, and use third quadrant projection.

In the vertical Plane I, draw a construction line  $e-g$ , horizontally, in such a way that it intersect two of the axes, say  $Y'$  and  $Z'$ , in the points  $e$  and  $g$  respectively. Project from the points  $e_1$  and  $g_1$  to Plane II, locating  $e_2$  and  $g_2$  as the intersections of the corresponding projection lines and axes. Draw the line  $e_2-g_2$ .

Select a third Plane III, adjacent to Plane II, by drawing the folding line  $Fl_{2-3}$  perpendicular to  $e_2-g_2$ . Now since the line  $e-g$  is horizontal, its projection on the horizontal plane will be parallel to it. Plane III will be perpendicular to it, and it will project on Plane III as a point  $e_3g_3$ . Further, Plane III will also be perpendicular to the plane  $Y'OZ'$ , and this plane will project on Plane III as the line  $O_3Y'_3Z'_3$ . Now project  $OX'$  and the vector  $OP$  to Plane III.

The component of  $OP$  parallel to the  $OX'$  axis can now be found on Plane III by drawing the line  $P_3-R_3$  parallel to  $O_3X'_3$  until it intersects the plane  $Y'OZ'$ , i.e. the line  $O_3Y'_3Z'_3$ . This will give one projection of the point  $R$ . The other may be found on Plane II as the intersection of a projection line from  $R_3$  and a line drawn through  $P_2$

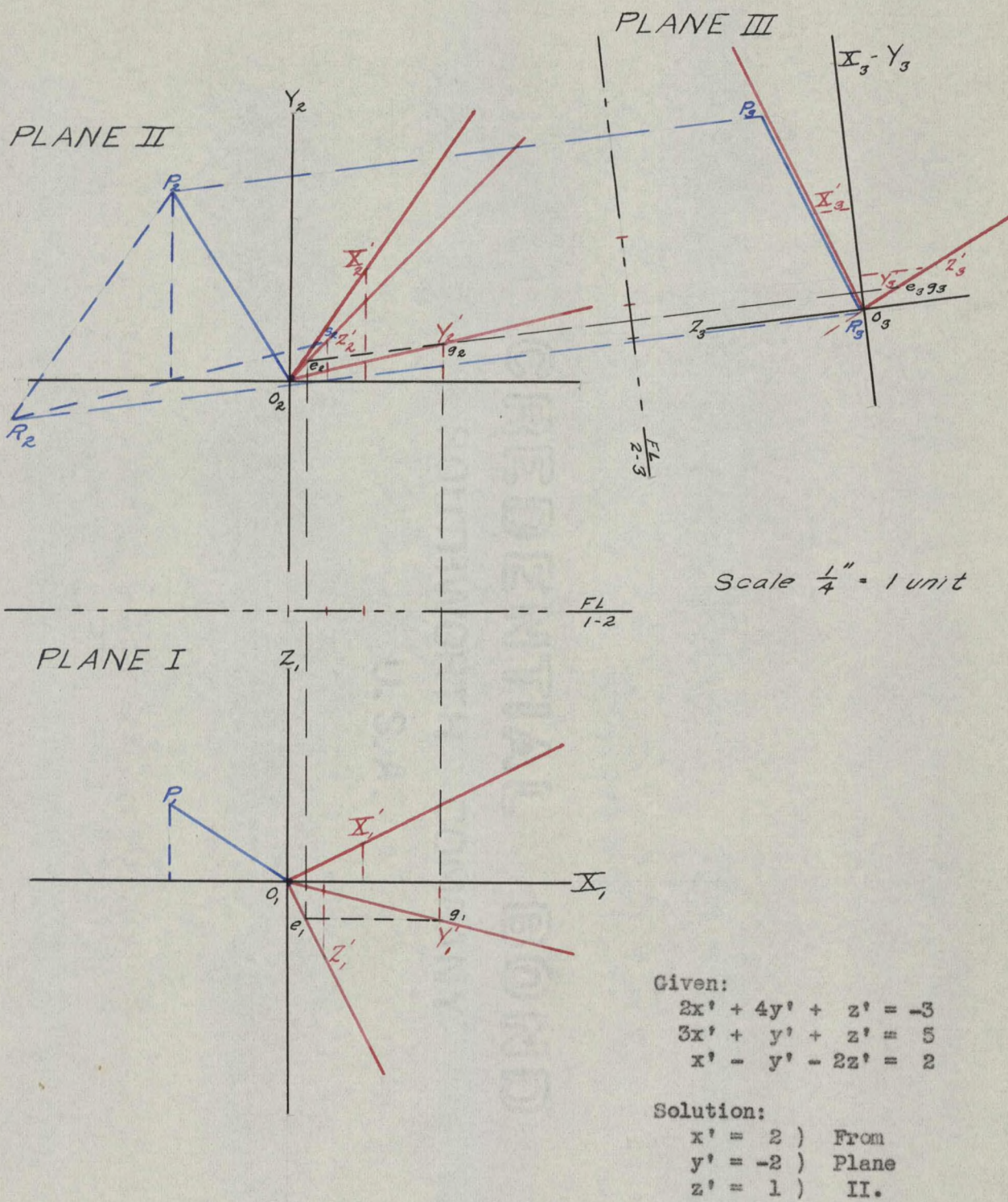

Fig. 5 Graphical Solution of Simultaneous Linear Equations

parallel to  $O_2X'_2$ . From the point  $R_2$  thus located, a line parallel to  $O_2Y'_2$  (or  $O_2Z'_2$  if preferred) can be drawn until it intersects the other axis in  $S_2$ . Now  $OS_2$ ,  $SR_2$ , and  $RP$  will be the three component lines required, and their respective lengths in terms of the unit lengths of each of the corresponding axes will be the required values of the respective coordinates.

Since each of these lines is parallel to its respective axis, it is not necessary that we have projections of each in its true length to ascertain these values, however, for each one will be foreshortened on any projection plane in exact proportion to the foreshortening of the unit distance of the corresponding axis on the same plane. In other words the required values of  $x'$ ,  $y'$ , and  $z'$  can be found from Plane II as the lengths of the projections of the corresponding component lines on that plane in terms of the corresponding axial unit distances as shown on the same plane, or:

$$x' = \frac{R_2P_2}{O_2X'_2} \quad y' = \frac{S_2R_2}{O_2Y'_2} \quad z' = \frac{O_2S_2}{O_2Z'_2} \quad (9)$$

These ratios can be easily evaluated by any one of several methods, the easiest perhaps being to measure the length of the projection of  $RP$ , for instance, with a divider set for the projected length of the  $OX'$  unit. Thus the equations can be solved by a purely graphical procedure. Further, the method is perfectly general for all two and three equation systems with constant coefficients, having only physical limitations as we find common in all graphical procedures.

### The Tensor Notation:<sup>20</sup>

We now reach a point where we can profitably introduce some of the valuable concepts of tensor notation, since this notation is particularly adapted to problems of the type we have been discussing, and will save us much time and trouble in the applications which are to follow.

Instead of indicating a series of variables as we have done heretofore by means of an "x", a "y", and a "z", only one symbol will be used, with

different indices to distinguish between different variable quantities it may represent. Thus, instead of the above, we would use  $x_1$ ,  $x_2$ , and  $x_3$ . We now make two additional modifications. First, the letter "y" is commonly used to indicate a system of variables in rectangular Cartesian coordinates, while "x" is used to represent variables in any system. Also, the type of vector we have been considering would be known as "contravariant", and superscripts rather than subscripts are commonly used in its representation. Our values would now be represented by  $y^1$ ,  $y^2$ ,  $y^3$ , for the x, y, and z, respectively, and  $x^1$ ,  $x^2$ ,  $x^3$ , for  $x'$ ,  $y'$ , and  $z'$ .

Another convention is the use of a literal index to represent all the numerical index values from 1 to 3 in turn. Thus  $y^r$  would represent  $y^1$ ,  $y^2$ ,  $y^3$ , and our equations (5) now become:

$$\begin{aligned} x^1 &= C_1^1 y^1 + C_2^1 y^2 + C_3^1 y^3 \\ x^2 &= C_1^2 y^1 + C_2^2 y^2 + C_3^2 y^3 \\ x^3 &= C_1^3 y^1 + C_2^3 y^2 + C_3^3 y^3 \end{aligned} \quad (10)$$

or to shorten the notation by use of literal indices:

$$\begin{aligned} x^1 &= \sum_{r=1}^3 C_{r1}^1 y^r \\ x^2 &= \sum_{r=1}^3 C_{r2}^2 y^r \quad \text{or} \quad x^S = \sum_{r=1}^3 C_{rS}^S y^r \\ x^3 &= \sum_{r=1}^3 C_{r3}^3 y^r \end{aligned} \quad (11)$$

It has been further agreed that when one index appears twice in the same term -- as it does on the right side of equations (11) -- a summation of the three terms represented will be assumed, and the summation sign may therefore be omitted. These equations then become:

$$x^S = C_{rS}^S y^r \quad (12)$$

which is the usual form of tensor notation for equations such as those we have been considering. In tensor analysis these equations are said to represent a transformation, and in particular if all the values of the matrix  $C_r^s$  are constant, the transformation is linear. Also, each member of the above "tensor equation" is an invariant, since it is not changed by the transformation. These concepts are exactly what we observed in the study of equations (5) and (6) graphically, for the  $C_r^s$  is the set of constant coefficient values, while the members represent the space vector OP. It may be pointed out that this vector is represented by its components, as it always will be, and that it is these values, not the vector, which are changed during the transformation.

A vector such as OP, represented by three component values, is known as a tensor of the first order. The matrix  $C_r^s$  represents nine different terms, and is known as a tensor of the second order. Here it is the tensor of transformation, and will be known as the transformation tensor or matrix. The determinant of the nine values represented will be indicated by  $|C|$  and will be known as the determinant of the transformation, being identical with the "D" of equations (2) and (3).

So far we have been discussing the tensor equivalent of equations (5) though it was found that the form of equations (6) was much more useful for our purposes. In order to reduce the equations represented by the tensor equation (12) to a form comparable with that of equations (6), it will be necessary to obtain a matrix or tensor which is the "inverse" of  $C_r^s$ , and which will be represented by the symbol  $\sqrt{r}^s$ .

This "inverse" form is defined such that each element of the determinant  $|\gamma|$  is the value of the cofactor (see page 12) of the corresponding element in  $|C|$  divided by the value of  $|C|$ . Using these symbols, equations (12) now become:

$$y_r = \gamma_r^s x_s \quad (13)$$

However, here the indices are subscripts, indicating "covariant" tensors -- which are defined as those tensors which transpose inversely to the contravariant tensors as shown here. This covariant vector can be drawn in much the same way that the contravariant one was, but the component values are no longer the coordinates of the terminal point with respect to the various axes. Thus from a graphical standpoint, the covariant form is not useful to us, and it will be necessary to change this vector into a contravariant one. This can be done simply by "transposing" the transformation tensor, i.e. by interchanging the rows and columns in its determinant, and then shifting the indices of the component vector values. The equations now are in the desired form, equivalent to equations (6).

$$y^r = \gamma_r^s x^s \quad (14)$$

Many problems in connection with electric circuits involve systems of simultaneous equations, and the tensor notation as well as the graphical methods developed above are very applicable to these. It will be noticed in equations (14) that the Cartesian coordinates are in the left hand member, and this member has only the one set of quantities involved. This is an indication that we are going to use the Cartesian coordinates as the original reference system (as we have done in the graphical development).

Thus it will be the most convenient to indicate the voltages in electric circuit problems by means of these "y" values, for in most cases the voltages are impressed upon, or fixed by conditions outside the network, while the currents depend upon the voltages and the network constants.

Since the coefficient values discussed in this part are real and constant, these will represent resistance values only, and we can represent the transformation matrix by  $R_n^m$ . Thus a system of three simultaneous equations in a direct current network would have the form:

$$E^m = R_n^m I^n \quad (15)$$

which is similar to that for a single element in ordinary notation.

It can be shown that equations for complicated networks, or for the analysis of complicated machinery, can be reduced to some such simple tensor expression. This is perhaps one of the most valuable aspects of this application, for with this notation there is no longer a need to set up a new equation each time a new problem is attacked, or the conditions of a given problem are changed. The close relationship which exists between various types of problems is kept in evidence, and mental and mathematical processes are therefore kept at a minimum.

The transformation shown by equations (12), (14), and (15) is one of the fundamental ones in tensor analysis. We have therefore not only demonstrated a method of solving three simultaneous linear equations, but have also given a graphical interpretation of this important transformation as well as of the fundamental tensor concepts of a contravariant vector and an invariant.

Such a transformation, of course, has a wide-spread application in all types of problems, and in any of these the graphical method presented here may be used to supplement other types of analysis. In electric circuit problems, Kron<sup>21</sup> has shown that such a transformation may not only be used to obtain currents in terms of voltages and resistances, or vice versa, but it may also be used to calculate currents in a system after a rearrangement of system elements in terms of the currents before, voltages after in terms of voltages before, and other types of relationships. There will not be room here to mention all types of such applications. A few are presented, more to illustrate the procedure than to cover any one branch of the field, and more extended applications will be made in later parts of this thesis.

#### Applications to Problems:

The problems presented here deal with applications to electric circuits only, though it should be kept in mind that the method used can be applied in other fields as well as to other types of electrical problems just as readily. Since, in this section, we are dealing with real numbers only, the problems will involve only resistances and direct current networks. Actual solutions are not carried out, as the methods are those presented above. In each case, however, the equations and transformation matrix are indicated.

It should be kept in mind that for purposes of graphical analysis and for problems where it is not necessary to evaluate the "implicit" variables, the method can be applied to any problem which involves a system of simultaneous linear equations. The problems presented here are confined to those

which involve not more than three independent equations, and which therefore can be "solved" by the graphical method.

Problem 1. Given a network as shown in fig. 6, set up equations for voltages in terms of three of the currents, and arrange the transformation matrix.

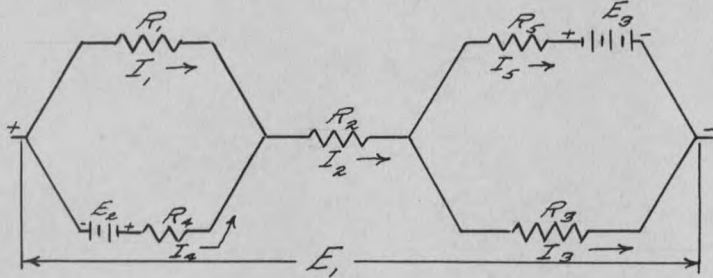

Fig. 6 Network for Problem 1.

Equations:

$$E_1 = I_1 R_1 + I_2 R_2 + I_3 R_3$$

$$E_2 = -I_1 R_1 - I_1 R_4 + I_2 R_4$$

$$E_3 = -I_2 R_5 + I_3 R_3 + I_3 R_5$$

Matrix:

$$R_n^m = \begin{array}{|c|c|c|} \hline & R_1 & R_2 & R_3 \\ \hline R_1^m & -(R_1+R_4) & R_4 & 0 \\ \hline R_2^m & 0 & -R_5 & R_3+R_5 \\ \hline \end{array}$$

Problem 2. Given the network in fig. 7. Proceed as for Problem 1.

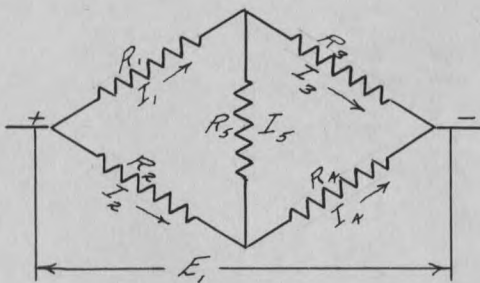

Fig. 7 Network for Prob. 2.

Equations:

$$E_1 = I_1 R_1 + I_3 R_3$$

$$0 = I_1 R_1 + I_1 R_2 + I_1 R_5 - I_3 R_5 - I_2 R_2$$

$$0 = I_1 R_5 - I_3 R_3 - I_3 R_4 - I_3 R_5 + I_2 R_4$$

Matrix:

$$R_n^m = \begin{array}{|c|c|c|} \hline & R_1 & 0 & R_3 \\ \hline R_1^m & R_1+R_2+R_3 & -R_2 & -R_5 \\ \hline R_2^m & R_5 & R_4 & -(R_3+R_4+R_5) \\ \hline \end{array}$$

Problem 3. Given the network in fig. 8, Proceed as for Problem 1.

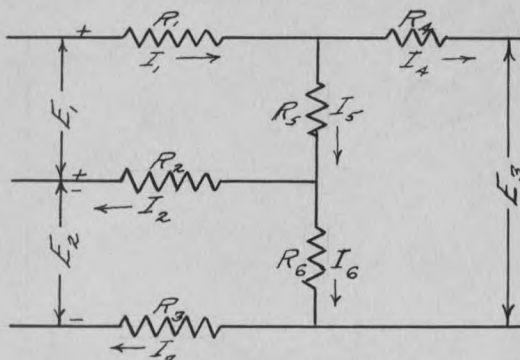

Fig. 8 Network for Prob. 3.

Equations:

$$E_1 = I_1 R_1 + I_5 R_2 + I_5 R_5 - I_6 R_2$$

$$E_2 = I_1 R_3 - I_5 R_2 - I_5 R_3 + I_6 R_2 + I_6 R_3 + I_6 R_6$$

$$E_3 = -I_1 R_4 + I_5 R_4 + I_5 R_5 + I_6 R_6$$

Matrix:

$$R_n^m = \begin{array}{|c|c|c|} \hline & R_1 & R_2+R_5 & -R_2 \\ \hline R_1^m & R_3 & -(R_2+R_3) & R_2+R_3+R_6 \\ \hline R_2^m & -R_4 & R_4+R_5 & R_6 \\ \hline \end{array}$$

The equations in each of the above problems give us three current values only. Of course, it can be seen that by proper substitution any three of the various values can be found. However, it is also possible to obtain the other current values in terms of the three considered by means of a second transformation as shown in the example given here.

Problem 4. Given the network of Prob. 3, fig. 8. By means of a graphical transformation, obtain the values of the currents,  $I_2$ ,  $I_3$ , and  $I_4$ , in terms of those values used in the equations, i.e.  $I_1$ ,  $I_5$ , and  $I_6$ .

The equations relating these currents are:

$$\begin{aligned} I_2 &= I_5 - I_6 \\ I_3 &= I_1 - I_5 + I_6 \\ I_4 &= I_1 - I_5 \end{aligned} \quad \text{or} \quad {}_2I^S = Y_{21}^S I^t \quad (16)$$

and the transformation matrix is:

$$Y_{21}^S = \begin{array}{|c|c|c|} \hline 0 & 1 & -1 \\ \hline 1 & -1 & 1 \\ \hline 1 & -1 & 0 \\ \hline \end{array} \quad (17)$$

Such a transformation may be plotted separately, assuming  $I_2$ ,  $I_3$ , and  $I_4$  as values in the rectangular Cartesian system. However, we can easily find the inverse transpose of matrix (17) as:

$$C_S^t = \begin{array}{|c|c|c|} \hline 1 & 1 & 0 \\ \hline 1 & 1 & -1 \\ \hline 0 & 1 & -1 \\ \hline \end{array} \quad (18)$$

and using this form we can work directly from the current axes of the graphical transformation for Prob. 3, finding a new set of axes whose coordinates will be the values of the three required currents. The graphical construction for this double transformation is shown in fig. 9, where values have been assumed for the resistances as follows:

$$R_1 = 2; \quad R_2 = 1; \quad R_3 = 4; \quad R_4 = 3; \quad R_5 = 3; \quad R_6 = 1.$$

giving the transformation matrix:

$$R_n^m = \begin{array}{|c|c|c|} \hline 2 & 4 & -1 \\ \hline 4 & -5 & 6 \\ \hline -3 & 6 & 1 \\ \hline \end{array} \quad (19)$$

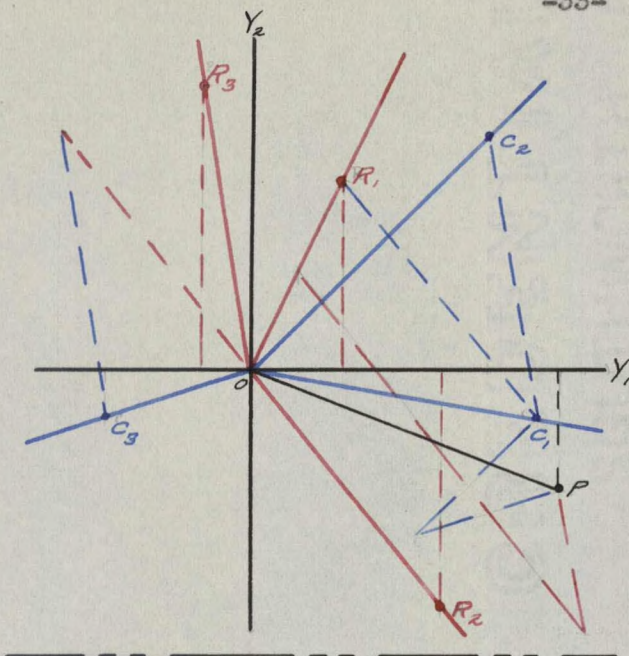

The space vector OP is shown in black, and the six components of OP parallel to each of the six transformed axes will be, respectively, the six required values of current. On the diagram the axes in red (labelled  $R_s$ ) are parallel, respectively, to the currents  $I_1$ ,  $I_5$ , and  $I_6$ ; the blue axes ( $C_t$ ) giving the values of  $I_2$ ,  $I_3$ , and  $I_4$  in order.

Since both sets of axes are at various angles, it will be necessary to draw two additional projection planes, one perpendicular to a pair of the  $R_s$  axes, and the other perpendicular to a pair of the  $C_t$  axes, if we are to make a complete study of the problem. Such a complicated figure results, that unless a particularly open form is possible, it will hardly be practicable for actual study; and two separate figures will usually be much more convenient.

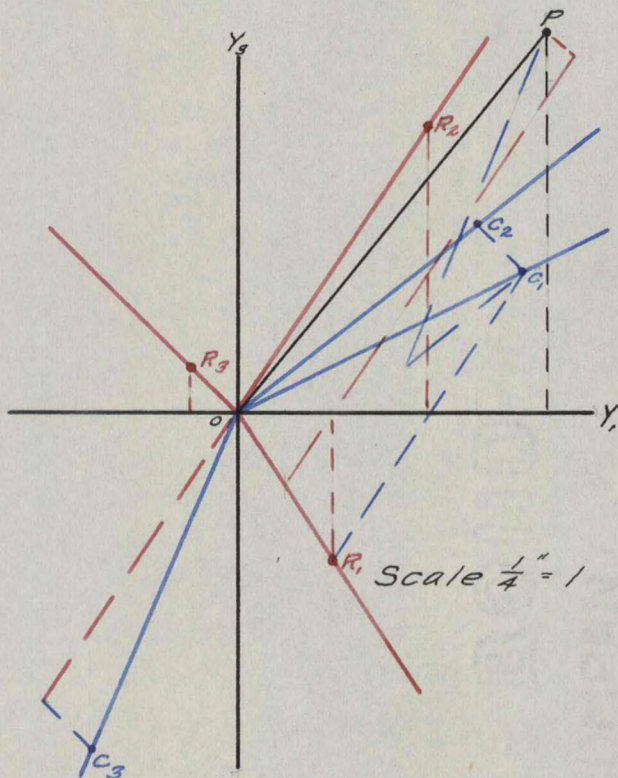

This application does, however, show a case where both of the transformation axes are in a general rectilinear form, and it also demonstrates the possibility of transforming from one set of current values to another. In addition, it shows the possibility of applying a "double transformation", i.e. a second transformation to a set of transformed axes, and gives a graphical interpretation of the tensor form:

$$E^m = C_n^m R_s^n I^s \quad (20)$$

where  $C_n^m$  is the tensor represented by the matrix (18),  $R_s^n$  is the matrix (19),  $I^s$  represents the currents  $I_2$ ,  $I_3$ , and  $I_4$ , and  $E^m$  are the three given voltage values.

Fig. 9 Double Transformation

Graphical Analysis:

One of the primary advantages of a graphical representation is that by means of it the effect of the change of one quantity on the other quantities may be observed directly without the necessity of mathematical calculation. We are particularly fortunate with this method in that each of the quantities involved is represented separately from the rest. It thus becomes an easy matter to make a graphical analysis of almost any nature desired. No attempt will be made here to discuss this phase of the development in detail, as this is an extensive study within itself. However, some of the types of analyses which can be made are indicated, with the idea in mind that they may at some time be studied more thoroughly, that the full value of these concepts may be realized.

Effect of Variation in One of the Implicit Coordinates:

A change in the value of any one of the six coordinates will affect only the position of P, and through this the value of some of the other coordinates. The positions of the axes, however, will not be affected. Interpreted electrically this merely means that changing the voltages or currents in a net-work will not affect the resistance values.

Such a change of implicit values can best be studied from a figure in two projection planes as is fig. 10. Care should be taken that the line representing the varying coordinate be drawn adjacent to P, and thus P will move along this coordinate line, or along the line PT in fig. 10, and the values of the other coordinates for any position such as P' can be observed easily.

It will be noticed that a change in one of the current values, such as  $I^3$ , will not affect the other current values, but will probably affect

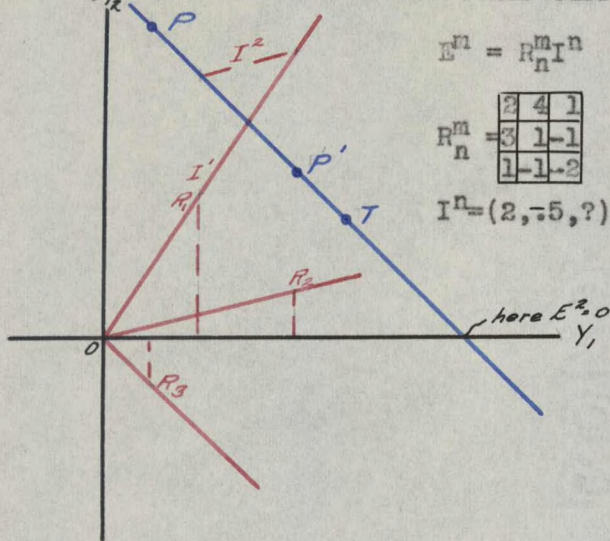

$$E^m = R_n^m I^n$$

$$R_n^m = \begin{bmatrix} 2 & 4 & 1 \\ 3 & 1 & -1 \\ 1 & -1 & -2 \end{bmatrix}$$

$$I^n = (2, -5, ?)$$

all three of the voltage components  $E^m$ . Zero value for one of the voltages will be found at some point such as P" where the line PT crosses the proper axis. In general the maximum values in such cases as shown here will be at infinity, though the relative rates of change of the various quantities can be obtained from an analytic study of the diagrams.

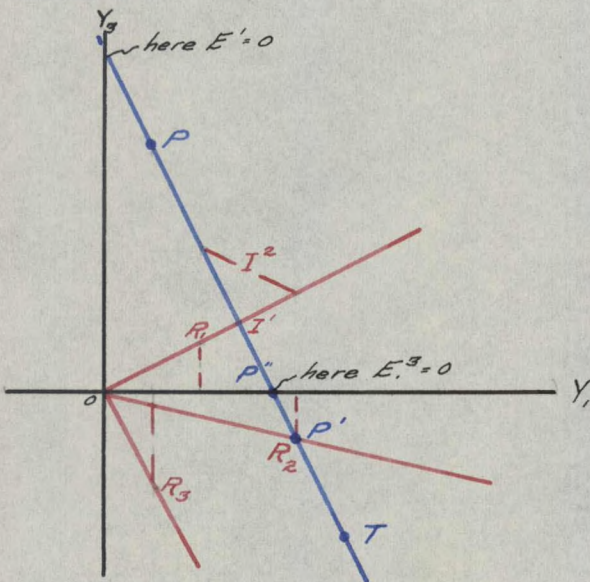

Fig. 10 Effects on Position of P as Coordinate  $I^3$  is Varied

A point should be emphasized here, and that is that at this stage we are stressing the mathematical rather than the electrical aspects of the problems involved. With any change in an electric circuit, there is associated certain transient effects due to the induct-

ance and capacity of the circuit. These effects are not considered in this thesis, but rather we will always consider a "change" as referring to a change in the steady state conditions of the circuit only.

Effect of Variation in Explicit Coordinates:

When the voltages are varied, the effect on the current values -- in the form we have been using -- is not so apparent, since now the problem becomes one of solving for the implicit variables for each new position of P. However, since the coefficient values are not changed, the position of Plane III (as in fig. 5) is not affected, and the necessity of working through this plane does not encumber the analysis unduly. Once again we notice that a change in one coordinate does not affect the other coordinates of the same set. In other words each of the voltages in a problem such as Prob. 1, page 31, may be varied independently of the others, but a variation in one of the voltages will usually affect all of the current values in one way or another.

Effect of Variation of the Coefficient Values:

When one of the coefficient values is altered, a more complex problem results, for while the position of the point P with respect to the origin is not necessarily changed, one or more of the transformed axes will be moved, and the coordinates of P in the transformed system will thus take on new values.

The best method of attack here is through a study of the change in position of the unit points. If but a single coefficient value is altered, all values will remain unchanged except one of the coordinates of one of the unit points. Such a variation must be linear as is shown in fig. 11 where the value of  $d_1$  (the resistance  $R_1$ ) is allowed to change.

The effect will make itself evident in the coordinate values in one of two ways. If the implicit, or current, values are assumed to remain unchanged, a new location of P in accordance with the new unit length of

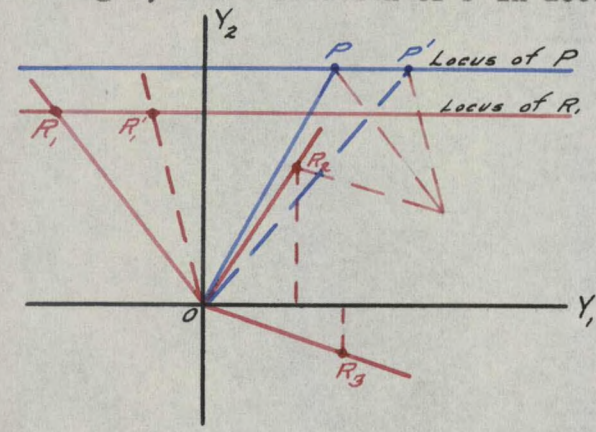

$R_1$  must be found. The corresponding values of the Cartesian coordinates can then be read off directly as was done in evaluating explicit variables.

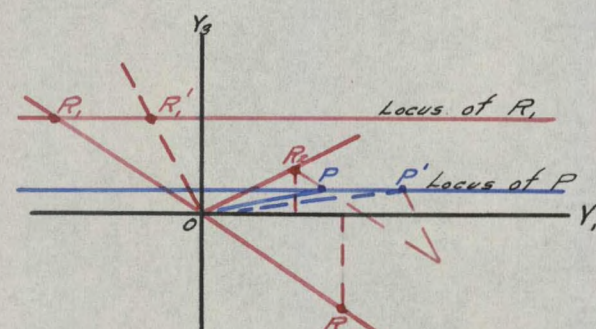

If, however, the voltages are assumed to remain constant while the resistance value is changed, the point P will not be affected, but the new current values must be found through use of Plane III as for the problem of solving the equations.

Fig. 11 Variation of Coordinate Values - Currents Held Constant

This Plane III will, of course, be taken perpendicular to the plane of the two unaffected axes, so that it will not change during the analysis. If care is taken that the position of point R (see fig. 5) is not affected, it is possible to carry out the analysis without working through Plane III at all. So many different conditions arise from the many different forms in which the data and requirements may be presented that no attempt will be made here, even to mention the forms such an analysis may take. These few hints are given to indicate the general methods, however.

Often in actual practice two or more of the coefficient values will vary simultaneously -- as is the case in each of the problems on page 31. If the relationship between these variations is known, and it will be in most cases, such problems can also be handled by using separate projection planes as in fig. 11. If the variation involves one unit point only, the locus of that point will now become a curve on one or both planes. If two coordinate values are involved, the two loci should be constructed and corresponding points on each selected for study. In either case the analysis will be based upon the principles mentioned above for variation in one value only. The study becomes more complicated, of course, as more values vary simultaneously, but no case has been found in the brief study which has been made of this aspect in which some type of analysis could not be made.

We have therefore found that the graphical representation of the tensor transformation is not only of value within itself for the new concepts which it presents to one unschooled in tensor methods, but it also has many interesting and useful applications, perhaps the most valuable of which is this graphical analysis. We will now proceed to extend these applications to include those conditions which are found in connection with a study of alternating current circuits.

PART II: APPLICATIONS TO PROBLEMS INVOLVING ALTERNATING CURRENTS

Problems Involving Resistance Only:

At the present time direct currents play such a relatively unimportant part in the field of electrical engineering that if the methods developed in Part I are to have any real use in electric circuit analysis, they must be extended to include the field of alternating currents as well. This will mean that the equations will involve complex numbers. Of course, such numbers can be plotted readily enough by using an axis of real values and an axis of imaginary ones, but an extension of this type of plotting to handle three simultaneous equations becomes too complex to be handled. The method which has been found most adaptable is to separate the transformation of the real values and that of the imaginaries, and to work with the two separate transformations.

For conciseness a tensor notation will be used throughout, and unless otherwise specified the voltage values will be referred to a rectangular Cartesian system as before. Also, we will continue to consider only steady state conditions, though now the circuit constants will include not only resistances, but inductances and capacitances as well. As is customary, these latter values will be considered as ohmic reactances, and will be indicated by the symbol "X". "R" will be used for resistance values, but now instead of the resistance matrix  $R_n^m$  we will deal with the impedance matrix  $Z_n^m$ , which will be complex in form, i.e. each element will be a complex number. Our general equation (15) now takes the form:

$$E^m = Z_n^m I^n \quad (21)$$

which is thus in a form similar to that of the equation for the simplest unit in an alternating current network, as given in ordinary notation.

It must be kept in mind that all values in equations (21) are complex. These may best be broken down into real and imaginary components as:

$$A^m + jB^m = Z_n^m(U^n + jV^n) \quad (22)$$

It will be best to consider at this point only those circuits which involve resistance only, for which equations (22) become:

$$A^m + jB^m = R_n^m U^n + jR_n^m V^n \quad (23)$$

and when the real values are set equal to the reals and imaginaries equal to imaginaries:

$$\begin{aligned} A^m &= R_n^m U^n \\ B^m &= R_n^m V^n \end{aligned} \quad (24)$$

Each of these equations is now identical with equations (15) and therefore can be represented by a homogeneous linear transformation as described in Part I. The transformation is seen to be the same for both sets of equations, and so only one set of transformed axes will be necessary. Two space vectors will be needed, however, and the values of the different components will be as shown in fig. 12. Fig. 13 shows the solution of an actual set of equations for the implicit values. A third plane must again be selected as in fig. 5, and this confines the method to not more than three equations. For convenience in visualizing, the "real" vector OA is represented in blue, while the "imaginary" vector OB is red.

Graphical analysis can be applied to this case as was done in the applications to direct current networks. As six additional component values are involved, added complexity will result. However, it will be

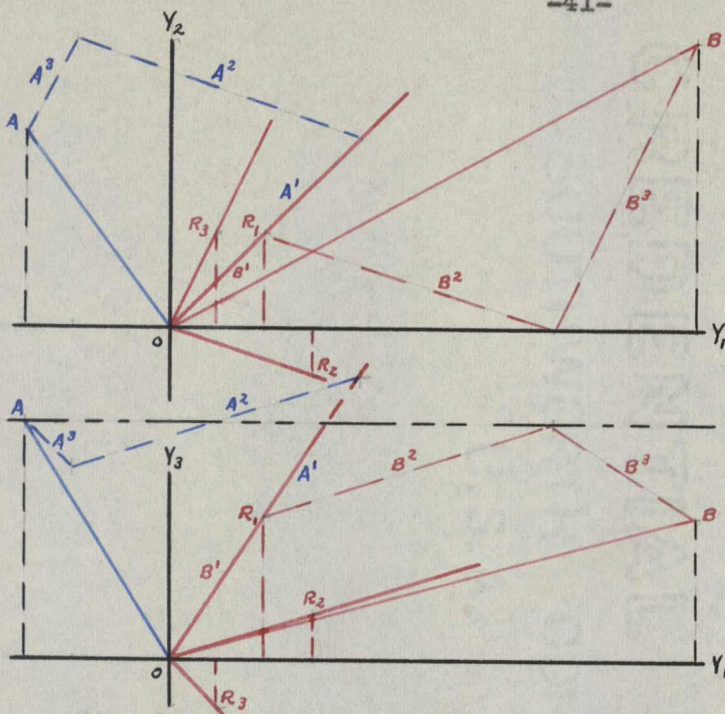

Equations:

$$E^1 = 2(2+j1) + 3(-2+j2) + (-1+j3)$$

$$E^2 = 2(2+j1) - (-2+j2) + 2(-1+j3)$$

$$E^3 = 3(2+j1) + (-2+j2) - (-1+j3)$$

$$R_n^m = \begin{bmatrix} 2 & 3 & 1 \\ 2 & -1 & 2 \\ 3 & 1 & -1 \end{bmatrix} \quad \begin{matrix} U^n = 2, -2, -1 \\ V^n = 1, 2, 3 \end{matrix}$$

Solutions:

$$A^m = -3, 4, 5 \quad E^1 = -3 + j11$$

$$B^m = 11, 6, 3 \quad E^2 = 4 + j6$$

$$E^3 = 5 + j3$$

Scale  $\frac{1}{4}'' = 1$

Fig. 12 Evaluation of Explicit Variables

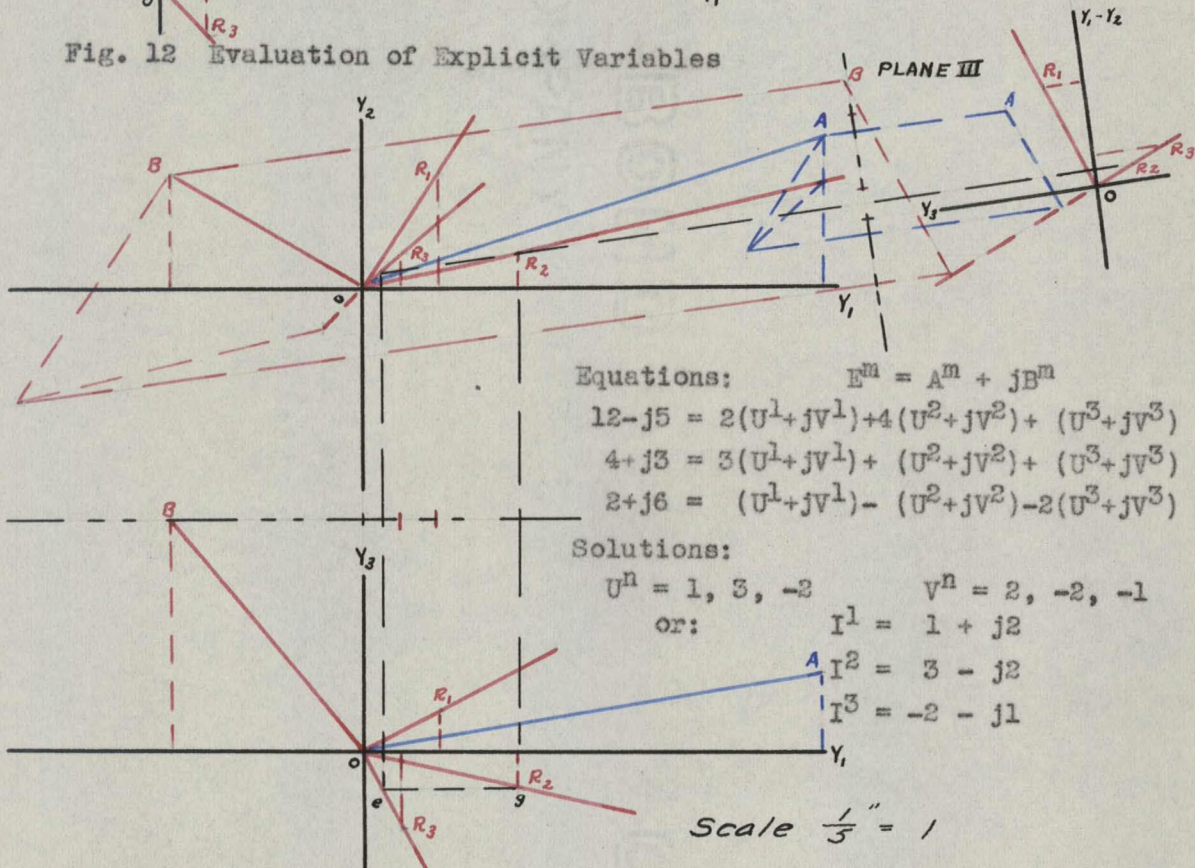

Equations:

$$E^m = A^m + jB^m$$

$$12 - j5 = 2(U^1 + jV^1) + 4(U^2 + jV^2) + (U^3 + jV^3)$$

$$4 + j3 = 3(U^1 + jV^1) + (U^2 + jV^2) + (U^3 + jV^3)$$

$$2 + j6 = (U^1 + jV^1) - (U^2 + jV^2) - 2(U^3 + jV^3)$$

Solutions:

$$U^n = 1, 3, -2 \quad V^n = 2, -2, -1$$

or:

$$I^1 = 1 + j2$$

$$I^2 = 3 - j2$$

$$I^3 = -2 - j1$$

Scale  $\frac{1}{3}'' = 1$

Fig. 13 Solving Equations with Complex Variables

noticed that a change in the real values will not affect the imaginary values, and vice versa, for this particular case. This is equivalent to saying that when a circuit has resistance only, the power factor angles between the currents and voltages are not affected by a change in the one set or the other.

The Problem when all Values are Complex:

When the impedance matrix  $Z_n^m$  involves complex numbers the problem becomes more complicated, but still can be handled within certain limitations. First the real and imaginary components of the matrix should be separated:

$$Z_n^m = R_n^m + jX_n^m \quad (25)$$

Three simultaneous linear equations of the type to be considered may be written in the form:

$$\begin{aligned} A^1 + jB^1 &= (R_1^1 + jX_1^1)(U^1 + jV^1) + (R_2^1 + jX_2^1)(U^2 + jV^2) + (R_3^1 + jX_3^1)(U^3 + jV^3) \\ A^2 + jB^2 &= (R_1^2 + jX_1^2)(U^1 + jV^1) + (R_2^2 + jX_2^2)(U^2 + jV^2) + (R_3^2 + jX_3^2)(U^3 + jV^3) \\ A^3 + jB^3 &= (R_1^3 + jX_1^3)(U^1 + jV^1) + (R_2^3 + jX_2^3)(U^2 + jV^2) + (R_3^3 + jX_3^3)(U^3 + jV^3) \end{aligned} \quad (26)$$

or in tensor form:

$$A^m + jB^m = (R_n^m + jX_n^m)(U^n + jV^n) \quad (27)$$

By expanding the right hand members of either of the above forms, it will be seen that:

$$A^m + jB^m = (R_n^m U^n - X_n^m V^n) + j(R_n^m V^n + X_n^m U^n) \quad (28)$$

and by separating the real values from the imaginary:

$$\begin{aligned} A^m &= R_n^m U^n - X_n^m V^n \\ B^m &= R_n^m V^n + X_n^m U^n \end{aligned} \quad (29)$$

thus giving the vectors  $A^m$  and  $B^m$  expressed as the sum or as the difference of two other space vectors.



It will be noticed at once that there are now two transformations involved. Since both of these may be taken from a set of rectangular Cartesian coordinates, both transformations may be shown on one diagram, though of course there will be an added complexity for we now have nine axes with which to deal instead of six as before. Fig. 14 shows the usual two-plane projection of a figure such as would be used for the evaluation of explicit forms or for graphical analysis. The "real" or "R" axes are shown in blue, the "imaginary", or "X" axes, in red, and the original "Y" axes in black. The "real" vector  $A^m$  is shown as a light blue line, with the two component vectors as light blue dashed lines. The vector  $X_n^{m,n}$  has been constructed in a reverse direction, then added to  $R_n^{m,n}$ . The "imaginary" vector  $B^m$  is similarly shown with its components in light red lines.

Such a diagram as shown in fig. 14 is too complicated to be used conveniently for the purposes we have in mind. Fortunately, however, most actual problems will have conditions which will simplify the diagram materially. Some examples of this are presented here.

Equations for a Two-Coil Transformer:

The relationship which exists (under steady state) between the voltages and currents in a two-coil transformer may be expressed as:<sup>23</sup>

$$\begin{aligned} E^1 &= Z_1^1 I^1 + X_2^1 I^2 \\ E^2 &= X_1^2 I^1 + Z_2^2 I^2 \end{aligned} \tag{30}$$

where the "Z" values represent the impedances of the coils, and the "X" values the reactive effects of the mutual inductance (all values are made "equivalent"). For this transformation, then, the two transformation

matrices will be:

$$R_n^m = \begin{bmatrix} R_1^1 & 0 \\ 0 & R_2^2 \end{bmatrix} \quad \text{and} \quad X_n^m = \begin{bmatrix} X_1^1 & X_2^1 \\ X_1^2 & X_2^2 \end{bmatrix} \quad (31)$$

making of  $R_n^m$  a "diagonal" matrix, and thus placing the "R" axes along the rectangular axes (though with unit points at different distances). Also

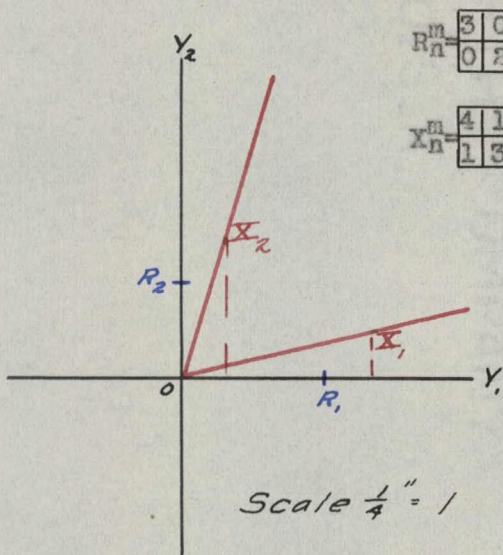

$$R_n^m = \begin{bmatrix} 3 & 0 \\ 0 & 2 \end{bmatrix}$$

$$X_n^m = \begin{bmatrix} 4 & 1 \\ 1 & 3 \end{bmatrix}$$

since  $X_1^2$  is the same as  $X_2^1$  the  $X_n^m$  matrix becomes "symmetric", i.e. it is not changed when transposed. The typical set of axes for such a transformation is shown in fig. 15. With only two equations, the representation can be made on one plane, and the values can be studied analytically at will.

Extensions to Three Coils:

By using two projection planes a study can be made of the voltages and currents in a three-coil transformer, or in any system of three coils having mutual inductance. The transformation matrices are:

$$R_n^m = \begin{bmatrix} R_1^1 & 0 & 0 \\ 0 & R_2^2 & 0 \\ 0 & 0 & R_3^3 \end{bmatrix} \quad \text{and} \quad X_n^m = \begin{bmatrix} X_1^1 & X_2^1 & X_3^1 \\ X_1^2 & X_2^2 & X_3^2 \\ X_1^3 & X_2^3 & X_3^3 \end{bmatrix} \quad (32)$$

Equations for Unbalanced Three-Phase Networks:

Assume a Y connected three-phase system with line voltages of three unequal values  $E_n^m$ , and three unequal impedance loads represented by "Z"

symbols ( $Z_1, Z_2, Z_3$ ). The equations for voltages in terms of the currents may now be written: (not tensor notation)

$$\begin{aligned} E_{1-2} &= Z_1 I_1 - Z_2 I_2 \\ E_{2-3} &= Z_2 I_2 - Z_3 I_3 \\ E_{3-1} &= -Z_1 I_1 + Z_3 I_3 \end{aligned} \tag{33}$$

for which the transformation matrices are:

$$R_n^m = \begin{bmatrix} R_1 & -R_2 & 0 \\ 0 & R_2 & -R_3 \\ -R_1 & 0 & R_3 \end{bmatrix} \quad \text{and} \quad X_n^m = \begin{bmatrix} X_1 & -X_2 & 0 \\ 0 & X_2 & -X_3 \\ -X_1 & 0 & X_3 \end{bmatrix} \tag{34}$$

and the transformation axes are shown in fig. 16.

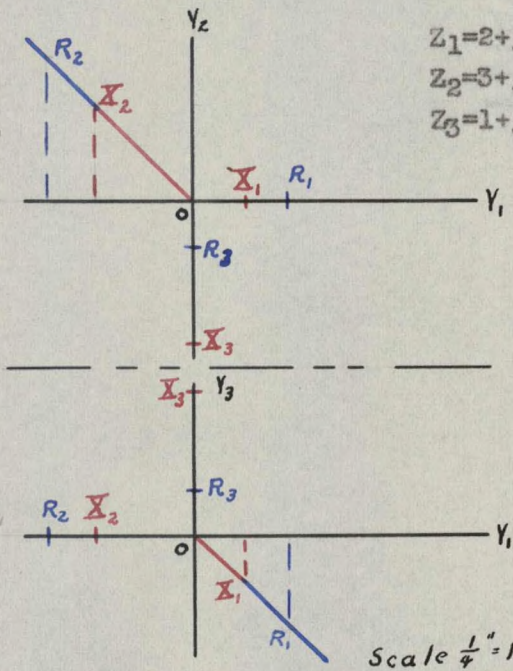

$$\begin{aligned} Z_1 &= 2+j1 \\ Z_2 &= 3+j2 \\ Z_3 &= 1+j3 \end{aligned}$$

Of course these are merely suggestions of the various ways in which equations may be set up for study. It will be noticed that the method is particularly adapted to a study of three-phase circuits, since in these circuits the customary set of three simultaneous equations occur very frequently.

Later another method of attack will be presented for such circuits. At

Fig. 16 Transformation for Unbalanced Three-Phase Circuits present we shall notice a few other aspects of the general method.

So far we have been concerned primarily with evaluating explicit forms. It will be seen that in the form in which these equations have been presented, many valuable studies of an analytical nature

similar to that discussed in Part I can be made, also. We do not go into detail concerning such applications here as no new methods are introduced, and we are more concerned in this thesis with a mention of several of the general applications which can be made than we are in too detailed a study of any particular one.

### Solving Equations in the Complex Form:

When we attempt to solve for the implicit values in those equations above which involve two transformations, difficulties are immediately encountered in breaking down the combined vectors  $A^m$  and  $B^m$  into the component vectors. So far it has not been found possible to solve such equations by a direct graphical procedure. Two alternate methods which allow graphical study, and which also aid the student in familiarizing himself with the methods involved are discussed here.

It is possible to change equations (21) into a form in which the currents are expressed explicitly by using the "inverse transpose" of the tensor  $Z_m^n$  as was done in Part I. This new tensor will be called  $Y_m^n$  and can be obtained in exactly the same manner as  $\gamma_{S}^R$  was obtained from  $C_T^S$  except that complex numbers will now be involved throughout the process and must be handled in the proper manner. The new tensor equation will now be:

$$I^n = Y_m^n E^m \quad (35)$$

These complex values can again be separated as was done for equations (29) by using  $(G_m^n + jF_m^n)$  for  $Y_m^n$ . ("F" is used instead of the usual "B" to prevent ambiguity with the "B" of the former equations.)

Equations (35) then become:

$$\begin{aligned}U^n &= G_m^n A^m - F_m^n B^m \\v^n &= G_m^n B^m + F_m^n A^m\end{aligned}\tag{36}$$

and these equations can be handled in the same manner as equations (29) have been handled in the above discussions.

#### Graphical Approximations:

Under certain conditions -- and it so happens that these conditions are those most commonly met in actual practice -- it is sometimes possible to obtain values close to the actual implicit values graphically by making an assumption which will lead to a series of approximations which under certain conditions will converge to the required values. These approximations are not given here as having any practical value, for all the methods are quite complicated, but they are useful in acquainting one with the various aspects of the graphical procedure we have been discussing.

Case I. The values of one of the two transformation matrices are small when compared to those of the other.

In such cases it is possible to obtain a first approximation by neglecting the smaller transformation. Successive approximations will converge toward a solution in some of these cases, and usually a trial of an approximation or two will show whether convergence or divergence is taking place.

a) When "R" is a diagonal matrix and its values are smaller than those of the corresponding diagonal in "X", the "R" values may be neglected for a first approximation. It has been found necessary that the graphical length of the units on the "R" axes must also be small when compared with any of the components of the given space vectors, but this can always be arranged by proper choice of scale lengths.

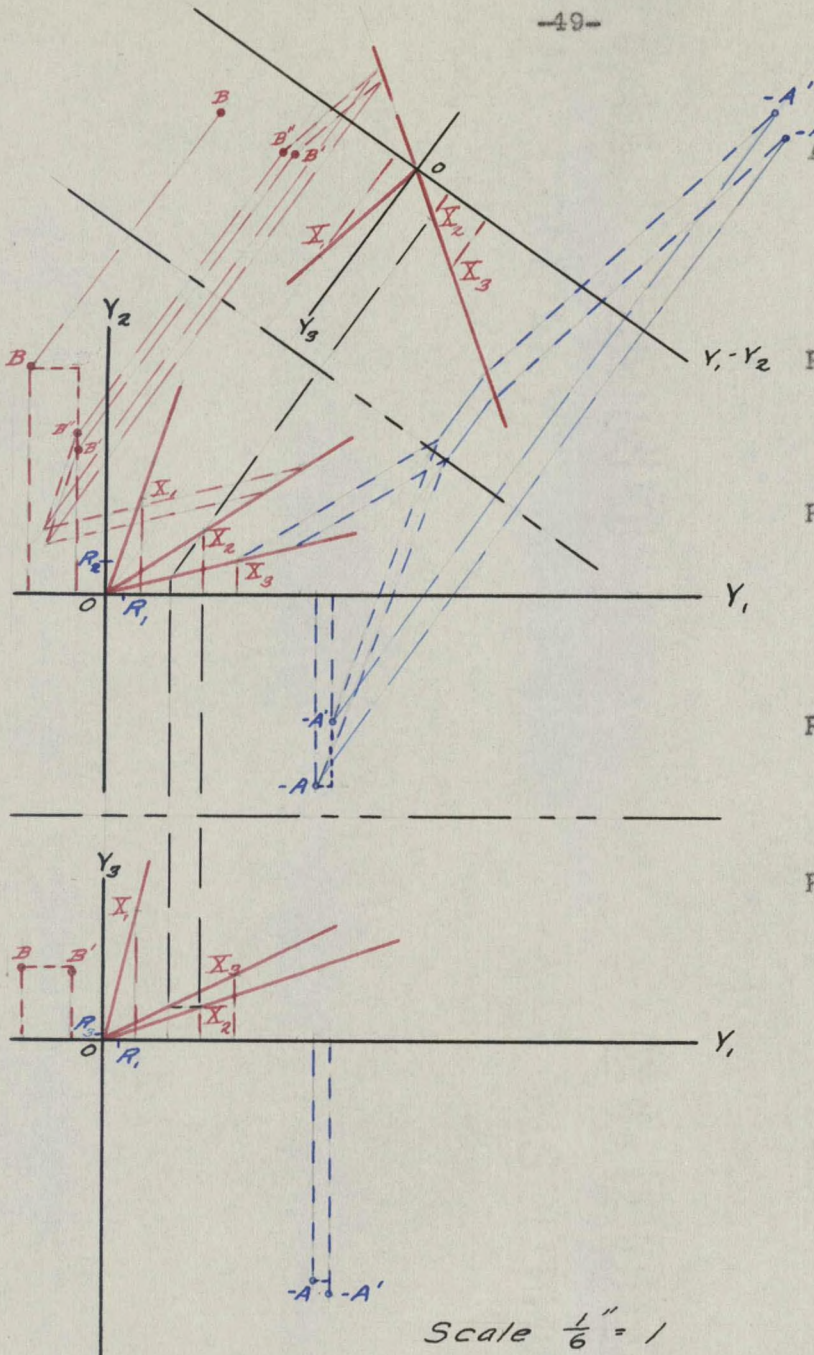

Approximations:

First:

$$\begin{aligned} V_1 &= -3.0 \\ V_2 &= 1.5 \\ V_3 &= 1.2 \end{aligned}$$

$$RV = (-1.5, 1.5, 0.24)$$

$$\begin{aligned} U_1 &= 1.2 \\ U_2 &= 1.6 \\ U_3 &= -1.9 \end{aligned}$$

$$RU = (0.6, 1.6, -0.4)$$

Second:

$$\begin{aligned} V_1 &= -3.0+ \\ V_2 &= 2.0+ \\ V_3 &= 1.0 \end{aligned}$$

$$RV = (-1.5, 1.0, 0.2)$$

$$\begin{aligned} U_1 &= 1.0 \\ U_2 &= 2.0 \\ U_3 &= -2.0 \end{aligned}$$

$$RU = (0.5, 2.0, -0.4)$$

Third:-Solutions

$$\begin{aligned} V_1 &= -3.0 \\ V_2 &= 2.0 \\ V_3 &= 1.0 \\ U_1 &= 1.0 \\ U_2 &= 2.0 \\ U_3 &= -2.0 \end{aligned}$$

Scale  $\frac{1}{6}'' = 1$

Equations:

$$-6.5 - j2.5 = (0.5 + j1)(U^1 + jV^1) + j3(U^2 + jV^2) + j4(U^3 + jV^3)$$

$$6.0 + j7.0 = j3(U^1 + jV^1) + (1 + j2)(U^2 + jV^2) + j1(U^3 + jV^3)$$

$$7.6 + j2.2 = j4(U^1 + jV^1) + j1(U^2 + jV^2) + (0.2 + j2)(U^3 + jV^3)$$

Fig. 17 Solving Three Simultaneous Equations by Successive Approximations

The procedure for such successive approximations is shown in fig. 17. The point  $-A$  is plotted as the negative of the terminal of the vector  $OA$  (the vectors themselves are omitted to avoid unnecessary lines). Neglecting the "R" values and solving for the "V" components of  $A^m$  from equations (29), it is found that by taking  $-A$ , the corresponding components along the "X" axes will be approximations of the "V" values. These are read off and recorded as the first approximation. A correction of  $-R_H^m V^1$  is then applied to the  $OB$  vector, giving the point  $B'$ . Solving as before we now obtain an approximation of the "U" values. A correction of  $R_H^m U^1$  is now applied to the position of  $-A$ , giving the point  $-A'$ , whose coordinates are the second approximations of the "V" values. This is continued, each time applying the corrections to the positions of the original points, until the values of the successive corrections in each case approach a constant value. Usually if there is convergence only three or four approximations are necessary.

Most transformer problems will be of this type, and we will also find included some of the problems involving inductive networks, particularly where the inductive values are large compared with the resistances involved.

b) When "R" is an ordinary square matrix, but the values are again small compared with those of "X", the same procedure can be applied. It has been found that in general the ratio of the values must be considerably greater in this case, and that cases in which divergence takes place are more common than for a).

c) When the "X" values are small compared with those of "R", they can be neglected for the first approximation and the procedure is the same as above with the "R" and "X" interchanged.

Case II. The values of the two transformation matrices are nearly equal.

a) Let the values of the two transformation matrices be identical. Equations (29) then reduce to:

$$\begin{aligned} R_H^m U^1 &= 1/2(B^m + A^m) \\ R_H^m V^1 &= 1/2(B^m - A^m) \end{aligned} \quad (37)$$

We can easily find the midpoint of the sum of the vectors  $OA$  and  $OB$ , and calling this point "C", we can solve for its coordinates along the three transformed axes. These coordinates will represent the required values of  $U^1$ . Likewise we can find the values of  $V^1$  from the midpoint of the sum of the vectors  $OB$  and  $-OA$ . This construction is shown in fig. 18.

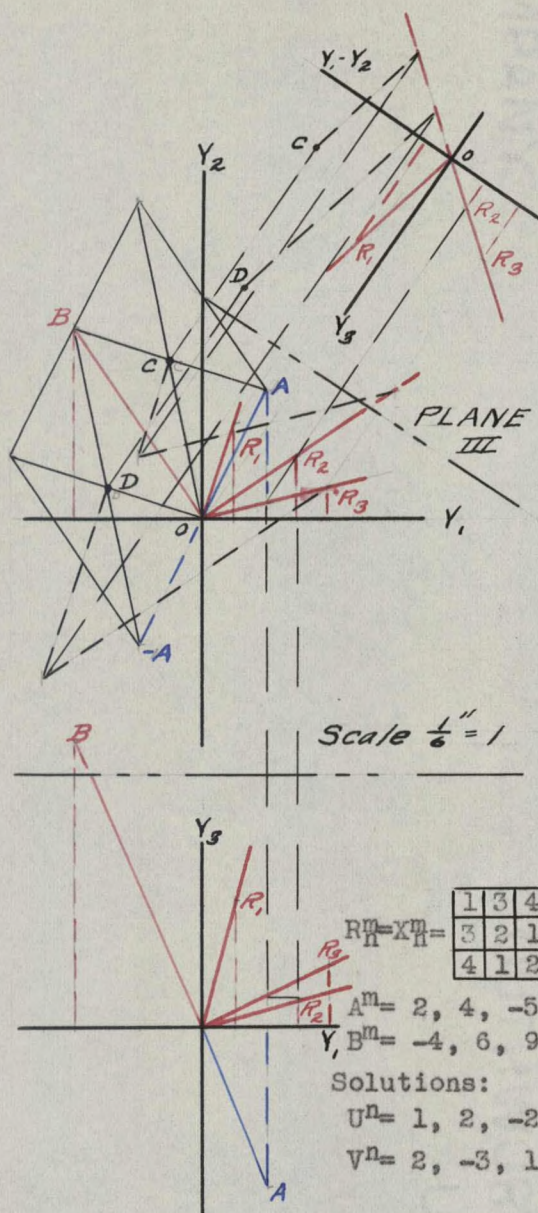

Fig. 18 Solution when the Two Matrices are Identical

Such a condition is ideal and will probably never be met in actual practice, but it does suggest a method of attack for problems where the "R" and "X" matrices are similar.

b) When both transformations are diagonal, and the values are approximately equal, the three sets of axes become rectangular.

A first approximation is obtained from the midpoints of the sum and difference of the two given vectors as described above; then these approximate values can be applied as corrections in the manner shown in Case I, either to find new midpoints for second approximations by this same method, or to be applied alternately in exactly the manner described for Case I, as often the one approximation will give close enough to the correct value that the simpler method of Case I will converge.

It will be noticed from fig. 19, which shows the transformation and vector construction for this case, that all the components can be read off directly in the two projection planes and Plane III is not needed.

It might be remarked that the three equations involved here are not at all inter-related, and therefore can be very easily solved algebraically. A special form of this case is a single equation involving complex values, which plots entirely along a straight line.

The case of unbalanced three-phase circuits, as given by equations (33) and shown in fig. 16, can, in some of its forms, also be handled by this method.

c) When the values of the "R" and "X" matrices are approximately the same, though both matrices may have a general form, approach is made in this same manner, though of course Plane III will now

be necessary. It will be found that problems which cannot be handled by the method of Case I can often be solved by taking the midpoints for a first approximation. If there is not too

much difference in the two sets of values, this method often gives an approximation close enough to converge toward a solution.

$$R_n^m = \begin{bmatrix} 2 & & \\ & 4 & \\ & & 1 \end{bmatrix}$$

$$X_n^m = \begin{bmatrix} 3 & & \\ & 5 & \\ & & 2 \end{bmatrix}$$

$$A^m = 10, -6, 7$$

$$B^m = 2, 13, -1$$

Approximations:

First:

$$U_R^n = 3, 1.0, 3.0$$

$$U_X^n = 2, 0.8, 1.5$$

Actual:

$$U^n = 2, 1, 1$$

Approximations shown for  $U^n$  values only

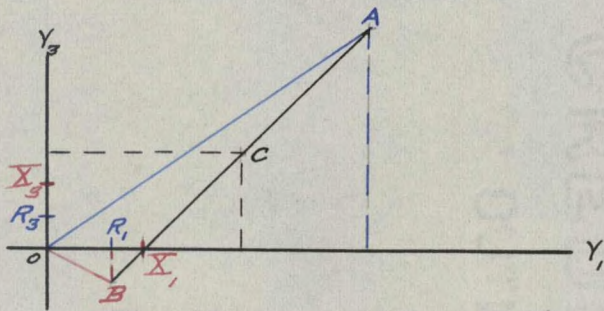
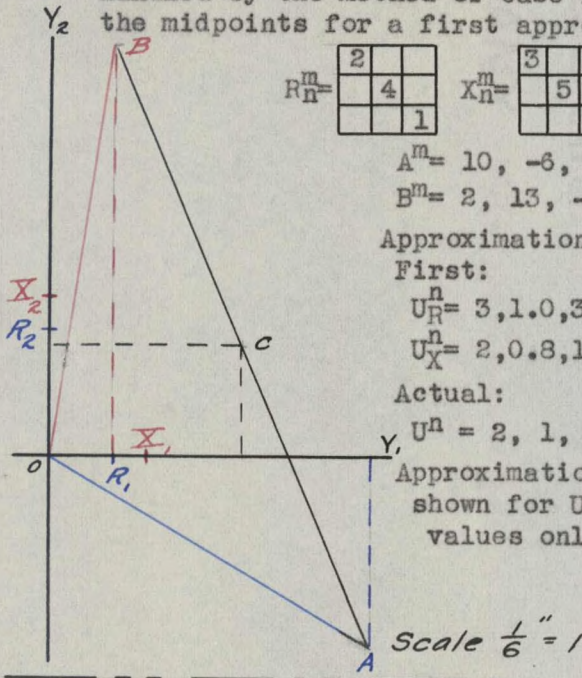

Fig. 19 Axes for Case II b)

The approach given here, as may be noticed, is quite complicated.

When all nine axes are separate, it becomes almost impossible, except on a very large plot, to keep the various values sorted out. Also the conditions under which useful approximations are obtained are so interrelated and difficult to determine beforehand that it is hard to set any definite rules.

It should be kept in mind with

all of these methods that convergence of the approximations will depend not only upon the relative values in the two matrices, but also upon the arrangement which these values have, and upon their interrelationship with the components of the space vectors. A positive test of whether or not a problem can be handled can only be made by trial, and it will be found that convergent approximations can be obtained in only a fraction of those cases where they might be expected.

As was remarked before, none of these methods is at all practical, except as an aid in the study of the method. Facility and understanding of the principles involved will come from attacking one or more such problems in this manner, but the algebraic solutions can be obtained more definitely and easily in all cases, and if a graphical study is required, it is best to use the equations (36) to obtain the explicit form.

Thus we have seen that with no more difficulty than would be expected from the more complicated mathematics involved, we have been able to extend our applications to include the field of alternating currents. Again, one of the most valuable aspects appears to be that of the graphical analysis, which can be performed with almost the same ease that was found in Part I. Three-phase circuits prove themselves particularly adaptable to handling by this method, and we shall now proceed to discuss an application which is specially useful in this type of circuit.

PART III: SYMMETRICAL COMPONENTS IN UNBALANCED THREE-PHASE CIRCUITS

Perhaps the most useful applications of this graphical method are to be found in three-phase circuits where unbalance makes desirable the computation of symmetrical components. The equations which give these components can be considered as representing a homogeneous linear transformation, since the coefficients involved are constant; and since the transformation matrix will be the same for all problems, it becomes possible to construct a chart from which the transformed values can be read directly.

Equations for Symmetrical Components:

If we have given three unbalanced voltages, or currents, in a three-phase circuit, it is possible to resolve these into three sets of balanced components, one with a positive phase sequence, one with a negative phase sequence, and one with zero phase sequence.<sup>24</sup> The equations for obtaining these "symmetrical components" are given as: (not tensor notation)

$$\begin{aligned}V^0 &= 1/3(V_a + V_b + V_c) \\V^1 &= 1/3(V_a + aV_b + a^2V_c) \\V^2 &= 1/3(V_a + a^2V_b + aV_c)\end{aligned}\tag{38}$$

where  $V_a$ ,  $V_b$ , and  $V_c$  are the three unbalanced voltages;  $V^0$ ,  $V^1$ , and  $V^2$  are values of a corresponding phase of the zero-phase, positive-phase, and negative-phase components, respectively; and "a" is an operator which produces a rotation of  $120^\circ$  in the direction of the phase sequence a, b, c. Thus "a" has a value of  $(-0.5 + j0.866)$  when  $V_a$  leads  $V_b$  in the usual crank phase diagram. " $a^2$ " will then be  $(-0.5 - j0.866)$ , and will produce a rotation of  $240^\circ$  in the same direction. We will assume this direction of rotation, and these values of "a" and " $a^2$ " throughout this section.

If we have given three unbalanced currents,  $I_a$ ,  $I_b$ , and  $I_c$ , we can likewise resolve them into symmetrical components by similar equations:

$$\begin{aligned} I^0 &= 1/3(I_a + I_b + I_c) \\ I^1 &= 1/3(I_a + aI_b + a^2I_c) \\ I^2 &= 1/3(I_a + a^2I_b + aI_c) \end{aligned} \quad (39)$$

The tensor equivalent of these two sets of equations will be:

$$\begin{aligned} 3E_\alpha &= S_{\mu\alpha}^m E_\mu \\ \text{and} \quad 3I_\alpha &= S_{\mu\alpha}^m I_\mu \end{aligned} \quad (40)$$

where  $S_{\mu\alpha}^m$  is the complex transformation matrix. Kron shows<sup>25</sup> by use of spinors (tensors involving complex numbers) that these current and voltage values transform the same way, though ordinarily under the assumption he makes of invariant power input, the current will transform as a contravariant vector, and the voltage as a covariant vector. In our discussion we have not made this distinction, in the first place because we do not wish to limit the discussion to those cases having invariant power (Kron shows the more general transformations in the later parts of his work), and in the second place we have always referred the voltages to a rectangular Cartesian system of axes. In such a system there is no difference between a contravariant and a covariant vector. Therefore, should we wish to apply this restriction it would make no difference in the above discussion except in the form of the tensor equations, which would then appear in exactly the form given by Kron.

Since the transformation tensor (or spinor)  $S_{\mu\alpha}^m$  is complex, it will be necessary to break it down into real and imaginary parts as was done for  $Z_{\mu\nu}^m$ .

These we will term  $R_m^C$  and  $Q_m^C$ , respectively. These matrix values are:

$$S_m^C = \begin{matrix} & \begin{matrix} 1 & 1 & 1 \end{matrix} \\ \begin{matrix} 1 \\ 1 \\ 1 \end{matrix} & \begin{bmatrix} 1 & 1 & 1 \\ -0.5+j0.866 & -0.5-j0.866 & -0.5-j0.866 \\ -0.5-j0.866 & -0.5+j0.866 & -0.5+j0.866 \end{bmatrix} \end{matrix} \quad (41)$$

and:

$$R_m^C = \begin{matrix} & \begin{matrix} 1 & 1 & 1 \end{matrix} \\ \begin{matrix} 1 \\ 1 \\ 1 \end{matrix} & \begin{bmatrix} 1 & 1 & 1 \\ -0.5 & -0.5 & -0.5 \\ -0.5 & -0.5 & -0.5 \end{bmatrix} \end{matrix} \quad \text{while} \quad Q_m^C = \begin{matrix} & \begin{matrix} 0 & 0 & 0 \end{matrix} \\ \begin{matrix} 0 \\ 0 \\ 0 \end{matrix} & \begin{bmatrix} 0 & 0 & 0 \\ 0 & 0.866 & -0.866 \\ 0 & -0.866 & 0.866 \end{bmatrix} \end{matrix} \quad (42)$$

These transformations are shown in the usual two plane projections in

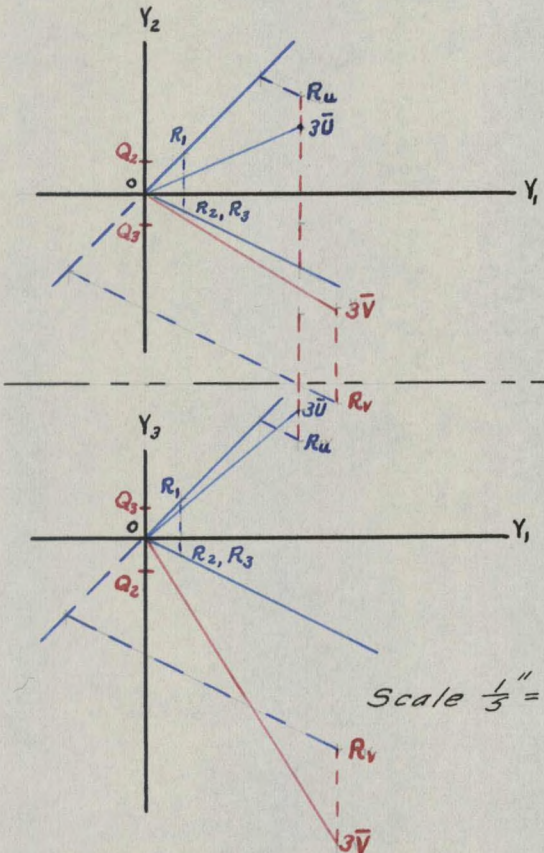

Fig. 20 Finding Symmetrical Components

fig. 20. Values are assumed for the unbalanced currents in equations (39) as:

$$\begin{aligned} I_a &= 3 - j2 \\ I_b &= 2 + j4 \\ I_c &= -1 + j3 \end{aligned} \quad (43)$$

These will be broken down into "U" and "V" values as before, but the transformed values will now be " $\bar{U}$ ", and " $\bar{V}$ " since this transformation involves currents only.

It will be noticed at once from fig. 20 that the  $R_2$  and  $R_3$  axes are identical. The  $R_1$  axis extends upward to the right at  $45^\circ$  in both projections; the  $Q_1$  axis is missing entirely, and the  $Q_2$  and  $Q_3$  projections fall along the  $Y_2$  and  $Y_3$  axes, with directions reverse in the two projection planes.

Scale  $\frac{1}{3}'' = 1$

The equations similar in form to (29) will now be:

$$\begin{aligned} 3\bar{U}^{\alpha} &= R_m^{\alpha} U^m - Q_m^{\alpha} V^m \\ 3\bar{V}^{\alpha} &= R_m^{\alpha} V^m + Q_m^{\alpha} U^m \end{aligned} \quad (44)$$

To evaluate  $3\bar{U}$  it is necessary therefore to move out three  $R_1$  units along the  $R_1$  axis, then  $(2-1)$ , or 1, of the common  $R_2, R_3$  units parallel to the common  $R_2 R_3$  axis. From this point, which is labelled  $R_u$  on fig. 20, we move vertically a distance of  $-4$  of the  $Q_2$  units plus a  $-3$  of the  $Q_3$  units, or since these units have the same length, but opposite directions, we can move in Plane II a  $-(4-3)$  or  $-1$  of these units, and in Plane I a  $-(-4+3)$  or  $+1$  of the same units. Likewise we can find the values of  $3\bar{V}$  by finding the point  $R_v$ ,  $V^1$  units along the  $R_1$  axis, plus  $(V^2+V^3)$  units parallel to the  $R_2 R_3$  axis; then from  $R_v$  moving vertically  $-(U^2-U^3)$  units in Plane I, and  $+(U^2-U^3)$  units in Plane II.

A Graphical Chart for Obtaining Symmetrical Components:

It will be noticed that except for the directions of  $Q_2$  and  $Q_3$ , Plane I and Plane II in fig. 20 are identical. The points  $R_u$  and  $R_v$  each occupy the same relative positions on both planes, and the distance vertically from each to the corresponding vector terminus is the same in magnitude but reversed in direction on the two planes.

These facts enable us to construct a chart as shown in fig. 21 which can be used for obtaining any symmetrical components for values within its range.

The point  $R_u$  will now be located at the intersection of the two lines passing through the points  $U^1$  on the  $R_1$  axis, and  $(U^2+U^3)$  on the  $R_{2-3}$  axis.

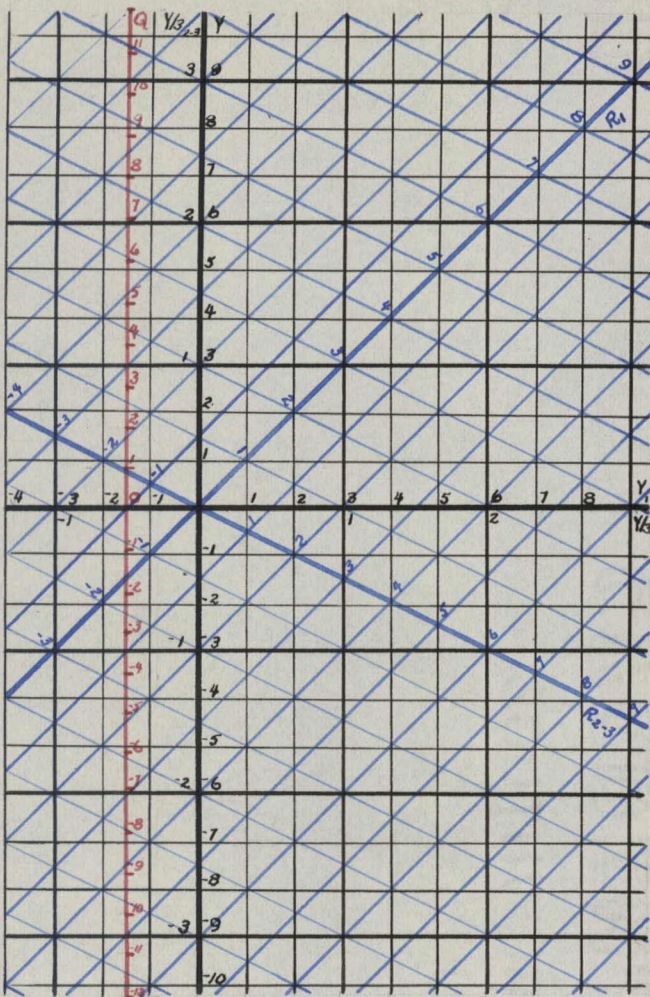

Fig. 21 Symmetrical Component Chart

The value of  $3\bar{U}^1$  is the  $Y_1$  coordinate of this point ( $R_u$ ). The  $3\bar{U}^2$  value will be found by moving vertically from  $R_u$  a distance of  $-(V^2-V^3)$  of the "Q" units, then reading the value on the  $Y_2$  axis.  $3\bar{U}^3$  will be vertically  $+(V^2-V^3)$  "Q" units from  $R_u$ .

The  $3\bar{V}$  values can be found likewise, except that  $3\bar{V}^2$  will be  $+(U^2-U^3)$  units, and  $3\bar{V}^3$  will be  $-(U^2-U^3)$  units from the point  $R_v$ . This reversal of sign is caused by the difference of signs in the equations (44), and is the point most likely to cause confusion in these operations.

These vertical distances will best be measured by a pair of dividers from the "Q" scale which is included on the chart, though placed a little to the left of the  $Y_{2-3}$  axis to prevent confusion. Better yet, a separate "Q" scale could be made and used as a ruler over the face of the chart.

In order to read the actual  $\bar{U}$  and  $\bar{V}$  values it is necessary only to have scales along the  $Y_a$  axes which will have units three times the length of the ordinary "Y" units. Such axes will be known as the "Y/3" axes, and

are shown on fig. 21, with heavy black lines to indicate these units on the graph. A chart to be fully useful should be large enough to have ten of these "Y/3" units in each direction. Then by proper handling of the decimal points, it will be found that such a chart will be large enough to accommodate practically any problem which may arise.

The Symmetrical Component Slide Rule:

As has been shown above, the horizontal components of the "R" points will give the values of  $\bar{U}^1$  and  $\bar{V}^1$ . But: 
$$\bar{U}^1 + j\bar{V}^1 = I^0 \quad (45)$$
 or these give us the values of the zero-phase components.

In actual practice these zero-phase components are commonly absent. If they are not, it is a simple procedure to determine their value as one-third of the vector sum of the three given quantities. They can then be subtracted from each, leaving an unbalanced system with no zero-phase components. If these are absent, however, equation (45) indicates that there are no horizontal components of the points  $R_{U1}$  and  $R_V$ . Therefore these points must in each case fall on the  $Y_{2-3}$  axis, making it possible for us to simplify our chart of fig. 21 into a slide rule by means of which we can determine the other two component values by taking four readings from two settings of the slide.

The slide rule will have four scales, three fixed, and one on the slide. Since the sum of the  $R_1$  components and the  $R_{2-3}$  components must always return to the vertical axis, we need have only one "R" scale along this axis,

the units of which will correspond with the intersections of the lines parallel to the  $R_{2-3}$  axis through each unit along the  $R_1$  axis, with the vertical  $Y_{2-3}$  axis. Other fixed scales will be the "Y" scale, and the "Y/3" scale as along the  $Y_{2-3}$  axis in fig. 21. The slide will carry the "Q" scale. In order that it can be used conveniently in a horizontal position, the positive values are kept to the right, and the negative to the left of the zero point, as is shown in fig. 22 below.

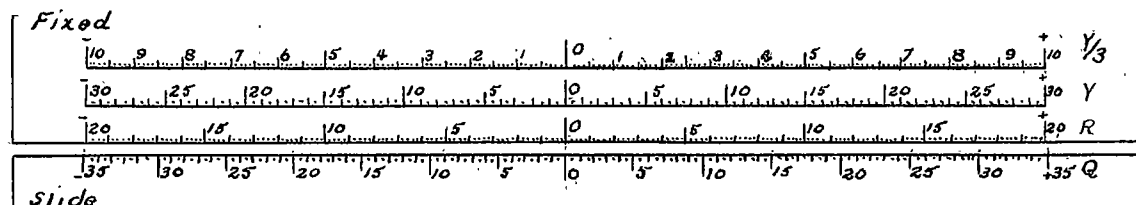

Drawn to 1/2 scale

Fig. 22 Scales for Symmetrical Component Slide Rule

Use of the Symmetrical Component Slide Rule:

Given a series of values, say voltages this time:

$$\begin{aligned} V_a &= A^1 + jB^1 \\ V_b &= A^2 + jB^2 \\ V_c &= A^3 + jB^3 \end{aligned} \tag{46}$$

in which there is no zero-phase component, i.e.  $V_a + V_b + V_c = 0$

Find the positive and negative phase sequence components:

$$\begin{aligned} V^1 &= \bar{E}^2 = \bar{A}^2 + j\bar{B}^2 \\ V^2 &= \bar{E}^3 = \bar{A}^3 + j\bar{B}^3 \end{aligned} \tag{47}$$

Only one value is necessary to find the point on the "R" axis, and that can most easily be the first. Thus set the "0" of the "Q" scale

opposite the value of  $A^1$  on the "R" scale. Determine  $(B^2 - B^3)$ . The point on the "Y", or better yet on the "Y/3", scale which is above  $-(B^2 - B^3)$  on the "Q" scale will give the required value of  $\bar{A}^2$ , while that above  $+(B^2 - B^3)$  will give  $\bar{A}^3$ . Setting "0" of the "Q" scale again, this time under  $B^1$  on "R", the values of  $\bar{B}^2$  and of  $\bar{B}^3$  will be found over points corresponding to  $+(A^2 - A^3)$ , and to  $-(A^2 - A^3)$ , respectively. Thus the four readings may be taken from two settings of the "Q" scale, and from these one of each of the component voltages (or currents) can be written down. If the other two vectors in any of the sets of balanced components are required, they may be obtained by rotating the known vector through  $120^\circ$  and  $240^\circ$ , respectively, in the proper phase sequence direction.

Design and Limitations of the Slide Rule:

The scale ratios for the slide rule can be found directly from the chart, fig. 21. These will be found to be:

$$\text{"Y"} : \text{"Q"} : \text{"R"} : \text{"Y/3"} = 1.00 : 0.866 : 1.50 : 3.00 \quad (48)$$

for corresponding unit lengths. Assuming a ten inch rule, and since it is much more convenient to have the scale with positive and negative sides, with zero at the center, we find that we can arrange to have ten of the "Y/3" divisions to each half-scale, giving lengths of main scale divisions, and number of divisions to the half-scale for the scales as shown in Table I.

TABLE I

Scale	Length of Division	No. Div. to 1/2 Scale
"Y"	0.167 in.	30
"Q"	0.144 "	35
"R"	0.250 "	20
"Y/3"	0.500 "	10

These divisions are large enough that the "Y" and "Q" scales can easily be subdivided into five parts for each main scale division, the "R" scale into ten parts, and the "Y/3" scale into twenty parts. This makes possible fairly accurate reading to two and three significant figures, and compares favorably in relative accuracy with other scales that would be found on the standard ten-inch slide rule. Longer rules, would of course, have correspondingly longer divisions, and would therefore give readings accurate to a greater number of significant figures.

This number of divisions will handle almost any problem without any difficulty. It is often necessary, of course, to use factors of 10,  $1/10$ ,  $1/100$ , etc. to reduce the data so that it will fit the scales, but if this is done uniformly, the results will be multiplied by the same factor. If some values are large, and others small, reduction should be made so that the large values will be on scale, with the smaller ones taking perhaps but fractions of main scale divisions. Relative accuracy will be kept by doing this. Some skill and experience will be necessary to handle these calculations smoothly, but several problems have been worked out using this rule, and no particular difficulty has been encountered, aside from the care which must be used in the directions along the "Q" scale.

#### The Inverse Transformation:

It is often desirable to change the symmetrical components back into the unbalanced values. Such an inverse transformation can also be handled on the chart or slide rule without particular difficulty. In order to obtain our transformation forms it is easiest to solve the three equations

(38) or (39) for the unbalanced values. This is most easily done through the tensor form of equations (40). Here let  $S_{\alpha}^m$  represent the inverse transpose of the tensor  $S_m^{\alpha}$ . Then:

$$E^m = S_{\alpha}^m E^{\alpha} \tag{49}$$

and  $I^m = S_{\alpha}^m I^{\alpha}$

and we find the values of  $S_{\alpha}^m$  (which absorbs the factor 3) to be:

$$S_{\alpha}^m = \begin{array}{|c|c|c|} \hline 1 & 1 & 1 \\ \hline 1 & a^2 & a \\ \hline 1 & a & a^2 \\ \hline \end{array} \tag{50}$$

giving us real and imaginary transformation matrices:

$$R_{\alpha}^m = \begin{array}{|c|c|c|} \hline 1 & 1 & 1 \\ \hline 1 & -0.5 & -0.5 \\ \hline 1 & -0.5 & -0.5 \\ \hline \end{array} \quad \text{and} \quad Q_{\alpha}^m = \begin{array}{|c|c|c|} \hline 0 & 0 & 0 \\ \hline 0 & -0.866 & 0.866 \\ \hline 0 & 0.866 & -0.866 \\ \hline \end{array} \tag{51}$$

But these will give us transformation axes identical with those in fig. 20, except that the  $Q_2$  and  $Q_3$  axes are interchanged. This will merely mean that we will now have to move in the reverse direction on the "Q" scale on the chart, and since there is no longer a factor of 3, we can read the values directly from the "Y" axes.

Use of the Slide Rule for Inverse Transformations:

Since the points  $R_u$  and  $R_v$  on the chart need no longer fall on the  $Y_{2-3}$  axis, the assumption on which the slide rule was constructed no longer holds. However, by some modifications we can adapt its use to the inverse transformations also. Let us see what these modifications are by once again considering an actual problem.

Given three symmetrical component values as:

$$\begin{aligned} I^0 &= \bar{U}^1 + j\bar{V}^1 \\ I^1 &= \bar{U}^2 + j\bar{V}^2 \\ I^2 &= \bar{U}^3 + j\bar{V}^3 \end{aligned} \tag{52}$$

Find the corresponding unbalanced values by means of the symmetrical component slide rule.

First, in order to use the slide rule, it is necessary once again to neglect the zero-phase components. These can be added to each of the values later. This will be the same as confining our directions with respect to the "R" axes on the chart to motion along the R<sub>2-3</sub> axis only. Now each unit along this axis is one unit of "Y" horizontally, and one-half unit in a negative direction vertically; or this is one-third of the length of an "R" unit on the slide rule, taken in a negative direction. Thus we will set the "0" of the "Q" scale opposite  $-1/3(\bar{U}^2 + \bar{U}^3)$  on the "R" scale. Values of  $\bar{U}^2$  and  $\bar{U}^3$  will be read off on the "Y" scale opposite points corresponding to  $+(\bar{V}^2 - \bar{V}^3)$ , and  $-(\bar{V}^2 - \bar{V}^3)$ , respectively, on the "Q" scale. The setting for the "V" values will be with the "0" of the "Q" scale opposite  $-1/3(\bar{V}^2 + \bar{V}^3)$ , with values of  $\bar{V}^2$  and  $\bar{V}^3$  read off on the "Y" scale opposite  $-(\bar{U}^2 - \bar{U}^3)$ , and  $+(\bar{U}^2 - \bar{U}^3)$ , respectively, on the "Q" scale.

Assuming that we have found these points, it is necessary to add in the zero-phase components for each one, that is:

$$\begin{aligned} I_a &= (\bar{U}^1 + \bar{U}^1) + j(\bar{V}^1 + \bar{V}^1) \\ I_b &= (\bar{U}^2 + \bar{U}^1) + j(\bar{V}^2 + \bar{V}^1) \\ I_c &= (\bar{U}^3 + \bar{U}^1) + j(\bar{V}^3 + \bar{V}^1) \end{aligned} \tag{53}$$

Analysis of Unbalanced Three-Phase Circuits:

We have now presented two methods of attack for analysis of unbalanced three-phase circuits. Many problems will be presented in a form where it is not necessary to obtain the symmetrical components, and in such cases the methods given in Part II can be applied. When symmetrical components will be useful for any reason whatsoever, the methods of this part should make it possible to obtain these easily.

Often it is also desirable to obtain the equivalent symmetrical components of the impedances in a three-phase network, so that having given the symmetrical components of, say, the voltages, the currents can be obtained directly in the symmetrical form. If the symmetrical form of both currents and voltages cannot be obtained directly in such a manner that these equivalent symmetrical impedances can be obtained from their values, formulae such as given by Kron in Part II of his work, equations (100)<sup>26</sup> can best be used for obtaining these. The symmetrical transformations just discussed can be used for the first steps in this transformation, and either the slide rule or chart can be used to advantage.

We have thus developed a tool which seems to be particularly adapted to three-phase systems. The symmetrical component slide rule is one application of our graphical method which apparently offers a real saving of time in the calculation of actual values. Therefore for these circuits, we not only have a method of graphical analysis, but we also have a useful graphical aid in the solution of problems.

PART IV:

THE METHOD IN GENERAL

If we are to use this graphical method advantageously, it is essential that we understand clearly all of its limitations, as well as those features of it which are in its favor. Some of these advantages and shortcomings have been mentioned previously, but are recapitulated here for emphasis, and to give here a summary of the various aspects we have been considering.

Advantages:

One of the obvious advantages of this method, which is common to all graphical presentations, is the ease with which a complete analytical study of the problem can be carried out. The whole problem is presented in a form which gives a concrete picture of what is taking place. One who has become familiar with the method of procedure used will soon find it possible to visualize the effects of certain changes in a network in terms of the changes which will take place in the corresponding space structure. Long mathematical computations are no longer necessary in order to study such changes, for the effects can be read off directly as from a chart.

By picturing a network as a space structure with its corresponding sets of axes, a new concept of the electrical circuit is introduced. No longer is a passive network just a group of wires, coils, and condensers through which voltages chase currents in accordance with some abstract mathematical formulae. Rather, the voltage and current quantities take on the form of a configuration within a space structure, with which they are related, but which they do not affect. The circuit constants become permanently unentangled from the quantities, such as voltage, current, flux, etc.

which are impressed upon the circuit. The relationship which exists is kept clearly apparent at all times, however, and the engineer who deals with a circuit from this point of view no longer deals with a passive entanglement of physical and mental quantities, but with a clearly organized space, as real in its sense as are the spaces with which the physicist has dealt so effectively in recent years. With his point of view in common with that of the physicist, he is further enabled to apply other valuable findings of this closely related field, as well as the important aspects which the mathematician has developed from a similar point of view.

Kron points out that these concepts are more fundamental than may at first be supposed. In his discussions he demonstrates clearly that the circuit constants, such as resistance, capacitance, inductance, etc., can always be associated with space structure, while the currents, potentials, fluxes, and other "impressed" quantities are considered as configurations within such spaces. From these fundamental points of view he proceeds to apply the powerful underlying relationships found by tensor analysis to the complex problems found in the analysis of rotating electrical machinery, and does so with a success that demonstrates the soundness of his reasoning. If this graphical method helps in any way to present such fundamental aspects in a clearer light, therefore, it will be of value for this one thing alone.

The ultimate possibilities of the concepts of, take the space vector for instance, can only be surmised at this point. Representing such diverse quantities as potential and current by the same space vector is certainly not in line with previously accepted procedure; and a presentation of these

quantities from such a different point of view may open the way to new findings concerning them.

Many persons, particularly those who have had considerable contact with advanced physics, mathematics, and kindred subjects, have reached a point where it is no longer necessary for them to have a physical picture of what they are dealing with in order that they can reason clearly. However, their most advanced reasoning was somewhere, in its early stages, perhaps, based upon such a physical form, and it was helpful to such persons in their early acquaintanceship with the subject to have such concrete forms to build on. Therefore it is hoped that picturization made possible by the method presented here will aid in the introduction of some of the great concepts involved to those who have not come into contact with them previously, and that it will stimulate, to some degree at least, an increased interest in the tensor analysis with which it is so closely related.

Limitations:

We should not overlook the various shortcomings of this method, however. Some of those are inherent with graphical analysis; some are weaknesses in the method itself; and others can be overcome by proper manipulation. At any rate, they should be thoroughly understood if the method is to be used successfully.

In common with other graphical methods, we will find that often the data will appear in such a form that it is physically impossible or impracticable to handle it. Sometimes, in such cases, it is possible to choose units in such a manner that lines which would be off the graph

otherwise, will be within handling distance. Once in a while a view of some of the lines or angles on critical planes will not be at all satisfactory. Often small drafting errors will introduce large errors in some of the values. Other troubles of a similar nature will be apparent, some but not all of which can be eliminated by drafting facility. It might be mentioned here that when Plane III is used, its selection must be made with great care, and only experience can give a definite idea of the best plane to use. In fact, skill and experience in drafting will be necessary to overcome a large number of the difficulties of this type.

As has been shown, the explicit forms may be evaluated in any number of dimensions by the proper selection of projection planes. It has not been found possible, however, to perform the reverse process, of solving the equations, in more than three dimensions, due to the difficulties of projection involved. Thus the application as a method of solving equations is confined to systems of not more than three simultaneous linear equations, and even here we must further confine ourselves to those equations which involve only one transformation except for the few cases which can be approximated as described in Part II. As the value of a graphical method in actually solving such equations is of relatively small importance, and further, as a large part of the equations which will be met in electrical circuit analysis will be within the required limitations, this shortcoming should not be considered too serious a one.

Care must be taken in the handling of real and imaginary values in the alternating current applications for there is no inherent way of telling

them apart. In our work we have used two colors, blue for the real values and transformations, and red for the imaginary ones (in general), with black for quantities involving both. This might be taken as a suggestion, or solid lines for one, with dashed lines for the other, could be used where color would not be practicable.

While this method introduces a new concept in the electrical space vector, it also does not show directly in any way the valuable time vector used so successfully in alternating current problems. The time vector can, of course, be readily computed at any time from the relationship between the real and imaginary quantities, but because of its value, the accepted forms of analysis stand in no danger of being supplanted by the space-vector-transformation method described here. Rather, this method should be considered as a valuable supplement to other methods now in common use.

#### Possible Value as an Introduction to Tensor Analysis:

As has been pointed out several times, the linear transformation discussed in this thesis is one of the fundamental forms in tensor analysis. The interpretation of three simultaneous linear equations as a linear transformation is within itself a tensor concept. By showing graphically exactly how this may be, and then picturing the transformation, an elementary insight is given into tensor analysis.

The concept of an invariant is clearly demonstrated in the space vector. The search for these invariants, which, while being related to a space structure, are not affected by a change in such a reference system, is one of the

prime objectives of tensor analysis. While the quantity discussed here is not one of the fundamental invariants, it has many of the properties of the more important ones, and it can be pictured graphically, whereas many of the others cannot be. Thus it should help to smooth the way for an understanding of the more complicated forms.

The difference is shown here between the first order tensor, or vector, and the second order tensor, which in this case was the transformation tensor. The definition of a tensor as "a system of numbers or functions whose components obey a certain law of transformation when the variables undergo a given transformation"<sup>27</sup> may now be better understood, since one such transformation is the type discussed here. A clear mental concept of tensors of the second and higher orders is difficult to obtain, but once again the mental pictures obtainable from these constructions should help clear away the mental hazards involved in the more difficult concepts.

We have also presented here a method of handling "spinors" or tensors involving complex numbers, and while we have not had to go into any of the technicalities of these, we perhaps have shown that while they are a little more involved than ordinary tensors, there is little difficulty aside from this added complexity in handling them. We have also used, without stressing the point, a weighted tensor in the transformation given in equations (40) and others in the same section. Such concepts will be clarified only with an actual study of tensor forms, but the mental pictures presented here may carry through to advantage in such study.

No attempt has been made here to present clearly the difference between covariant and contravariant vectors, since the former do not adapt themselves readily to graphical presentation. A mention of the difference of their laws of transformation was made, however; and it might be remarked that by an extension of the methods given here, a picture of the covariant form similar to that given of the contravariant form might be obtained, and used to clarify the study of these concepts if necessary; but such a presentation would be outside of the range of our discussion here.

Thus this presentation may have its value to the beginning student in tensor analysis. It seems perfectly possible that by proceeding along similar lines, graphical presentation of the vectors in some of the more complicated transformations, etc., could be made. Such may be of value within themselves, though in tensor work there is danger in trying to hang onto a physical picture of the systems too long. At least the transition from ordinary algebra to the simpler aspects of tensor analysis is bridged here in a manner that should make apparent the fact that while tensor analysis has many involved and complex concepts, its elementary forms are only a short step beyond the concepts of elementary algebra and analytic geometry.

#### Extended Applications:

The linear transformation in tensor analysis has already found a wide application in such fields as dynamics, physics, and geometry. Application to electrical problems when presented in a graphical form as done here, gives more or less valuable results; and there is no reason to believe that similar results will not come from applications in other fields. It may

not be possible to find many places where the system fits as admirably as it does the problems of unbalanced three-phase circuits, but it is at least interesting to speculate on the physical interpretation of the various components when applied in some of these other fields.

It is also highly probable that graphical interpretations of other applications of tensor analysis in the electrical field may lead to worthwhile results. Kron's work is full of such applications, only one or two of which have been mentioned here. Of course many of these are physically too complex to be considered, but on the other hand, many are well within the range of possibility. For example, the method used here could be applied directly in some of his analyses of the simpler motors, including some as complex as the three-phase induction motor.

Other possibilities are too numerous to mention, but it is sincerely hoped that by clarifying the understanding of some of the fundamentals, this presentation will help to spur others on to make wider and more detailed applications of this powerful tool which has so recently been placed in the hands of the engineer, namely, tensor analysis.

REFERENCES

1. Disc. on Paper by Eddy, A.E. Kennelly, AIEE Trans. v. XV, 1898, p. 504.
2. Complex Quantities and Their Use in Electrical Engineering, C.P. Steinmetz, Proc. Int. Elec. Congress, Chicago, Aug. 1893, p. 33-76.  
also, Alternating-Current Phenomena (book), Steinmetz, McGraw-Hill, 1897.
3. Impedance, A. E. Kennelly, AIEE Trans. v. X, Apr. 1893, p. 186.
4. Disc. on Paper by Kennelly, C.P. Steinmetz, AIEE Trans. v. X, 1893, p. 227.
5. Principles of Alternating Current Machinery (book), R. R. Lawrence, McGraw-Hill, 2nd Ed., 1921, p. 490.
6. Stand. Handbook for Elec. Engr., McGraw-Hill, 6th. Ed., 1933, Sec. 14-41.
7. Stand. Handbook for Elec. Engr., l.c. Sec. 14-42.
8. Stand. Handbook for Elec. Engr., l.c. Sec. 14-163-71.
9. Enter Tensors, L.V. Bewley, Gen. Elec. Review, v. 38, Apr. 1935, p. 167.
10. The Application of Tensors to the Analysis of Rotating Electrical Machinery, Part I, G. Kron, Gen. Elec. Review, v. 38, Apr. 1935, p. 181.
11. Tensor Analysis of Rotating Machinery (Abs.), G. Kron, Elec. Engg. Journal Abstracts, v. 52, Jan. 1933, p. 51.
12. The Application of Tensors to the Analysis of Rotating Electrical Machinery, Part V, G. Kron, Gen. Elec. Review, v. 38, Sept. 1935, p. 435.  
Salient Pole Motors Out of Synchronism, A.H. Lauder, Elec. Engg. v. 55, June 1936, p. 636-49.  
Tensor - A New Engineering Tool, A. Boyajian, Elec. Engg. v. 55, Aug. 1936, p. 856-62.  
Dyadic Algebra Applied to Three-Phase Circuits, A. Pen-tung Sah, Elec. Engg. v. 55, Aug. 1936, p. 876-82.  
Tensor Algebra in Transformer Circuits, L.V. Bewley, Elec. Engg. v. 55, Nov. 1936, p. 1214-19.  
Tensor Analysis of Multielectrode Tubes, G. Kron, Elec. Engg. v. 55, Nov. 1936, p. 1220-42.  
Parable of Tensor Analysis, J. Slepian, Elec. Jour. v. 33, Dec. 1936, p. 541-47.

- Complex Vectors in Three-Phase Circuits, A. Pen-tung Sah, Elec. Engg. v. 55, Dec. 1936, p. 1356-64.
- Tensors and Fruit Salads, J. Slepian, Elec. Jour. v. 34, Mar. 1937, p. 115-119.
13. The Application of Tensors to the Analysis of Rotating Electrical Machinery, Gabriel Kron, A series of articles appearing in the Gen. Elec. Review, v. 38, Apr. 1935 to v. 40, Nov. 1937.
  14. Applications of the Absolute Differential Calculus (book), A. J. McConnell, Blackie and Sons, Forward on Cover.
  15. Graphical Treatment of Alternating Currents in Branching Networks, Henry T. Eddy, AIEE Trans. v. XV, 1898, p. 461-504.
  16. Graphical Analysis of Alternating Current Circuits (book), Frederick W. Lee, Civil Engg. Dept., Johns Hopkins University, 1928.
  17. A Method of Using Secant and Tangent Ratios in a Circle for the Calculation of Impedances in Parallel, P. Boening, reprint in Electronics, v. 2, Jan. 1938, p. 54.
  18. Enter Tensors, L. V. Bewley, l.c. p. 167.
  19. Descriptive Geometry, I. W. Cutter, McGraw-Hill, 2nd Ed., 1927, p.30-31.
  20. McConnell, l.c. p. 19-22.
  21. Application of Tensors to the Analysis of Rotating Electrical Machinery, Part II, Kron, Gen. Elec. Review, v. 38, May, 1935, p. 240-43.
  22. What is Tensor Analysis?, B. Hoffmann, Elec. Engg., v. 57, Jan. 1938, p. 4, Eq. (1.10).
  23. Appl. of Tensors to An. of Rot. Mach., Part II, Kron, l.c. p. 240-43.
  24. Method of Symmetrical Co-Ordinates Applied to the Solution of Polyphase Networks, C.L. Fortescue, AIEE Trans. v. XXXVII, June, 1918, p. 1027-1115.  
also, Alternating Current Circuits (book), Bryant and Correll, McGraw-Hill, 2nd Ed., 1931, p. 243-44.
  25. Appl. of Tensors to An. of Rot. Mach., Part II, Kron, l.c. p. 239.
  26. Appl. of Tensors to An. of Rot. Mach., Part II, Kron, l.c. p. 242.
  27. McConnell, l.c. p. 20.

BIBLIOGRAPHY

- Backenstoss, Henry, April 1933. GRAPHICAL DETERMINATION OF SYMMETRICAL COMPONENTS, Elec. Engg. v. 52; p. 280-1.
- Bewley, L. V., April 1935. ENTER TENSORS, Gen. Elec. Rev. v. 38; p. 167.
- Bewley, L. V., Nov. 1936. TENSOR ALGEBRA IN TRANSFORMER CIRCUITS, Elec. Engg. v. 55; p. 1214-19.
- Boening, P., Jan. 1938. A METHOD OF USING SECANT AND TANGENT RATIOS IN A CIRCLE FOR THE CALCULATION OF IMPEDANCES IN PARALLEL, Hochfrequency technik und Elektroakustik, v. 50, No. 1, p. 32-4; reprint in Electronics, v. 2, No. 1; p. 54.
- Boyajian, A., Aug. 1936. TENSOR - A NEW ENGINEERING TOOL, Elec. Engg. v. 55, p. 856-62.
- Bryant, J. M., and Correll, J. A., 1931. ALTERNATING-CURRENT CIRCUITS, 2nd. Ed., 492 pp.; McGraw-Hill Co., New York.
- Cutter, L. E., 1927. DESCRIPTIVE GEOMETRY, 2nd. Ed., Chapters I - V; p. 1-78; McGraw-Hill Co., New York.
- Dwight, H. B., 1913. TRANSMISSION LINE FORMULAS; Van Nostrand Co., N. Y.
- Dwight, H. B., April 1934. A GRAPHICAL SOLUTION OF STEADY STATE STABILITY, Elec. Engg. v. 53; p. 566-68.
- Eddy, Henry T., 1898. GRAPHICAL TREATMENT OF ALTERNATING CURRENTS IN BRANCHING NETWORKS, AIEE Trans. v. XV; p. 461-504.
- Fortescue, C. L., June 1918. METHOD OF SYMMETRICAL COMPONENTS APPLIED TO THE SOLUTION OF POLYPHASE NETWORKS, AIEE Trans. v. XXXVII; p. 1027-1115.
- Gibbs, J. W., and Wilson, E. B., 1929. VECTOR ANALYSIS, 436 pp.; Yale University Press.
- Hoffmann, Banesh, 1938. WHAT IS TENSOR ANALYSIS?, Elec. Engg. v. 57, Jan. 1938 to Mar. 1938, Parts I - III.
- Kennelly, A. E., 1893. IMPEDANCE, AIEE Trans. v. X; p. 175-226.
- Kennelly, A. E., 1898. DISCUSSION ON PAPER BY EDDY, AIEE Trans. v. XV; p. 504.
- Kron, Gabriel, 1933. TENSOR ANALYSIS OF ROTATING MACHINERY (Abstract), Elec. Engg. Journal Abstracts, v. 52; p. 51.

- Kron, Gabriel, 1935-37. THE APPLICATION OF TENSORS TO THE ANALYSIS OF ROTATING ELECTRICAL MACHINERY, Gen. Elec. Review, v. 38-40, April 1935 to Nov. 1937; Parts I - XVII.
- Kron, Gabriel, Nov. 1936. TENSOR ANALYSIS OF MULTIELECTRODE TUBES, Elec. Engg., v. 55; p. 1220-42.
- Laplante, R., Dec. 1932. GRAPHICAL DETERMINATION OF THE SYMMETRICAL COMPONENTS IN A THREE-PHASE UNBALANCED SYSTEM, Elec. Engg., v. 51; p. 886-7.
- Lauder, A. H., June 1936. SALIENT POLE MOTORS OUT OF SYNCHRONISM, Elec. Engg., v. 55; p. 636-49.
- Lawrence, R. R., 1921. PRINCIPLES OF ALTERNATING CURRENT MACHINERY, 2nd. Ed., 614 pp.; McGraw-Hill Co., New York.
- Lawrence, R. R., 1935. PRINCIPLES OF ALTERNATING CURRENTS, 2nd. Ed., 475 pp.; McGraw-Hill Co., New York.
- Lee, Frederick W., 1928. GRAPHICAL ANALYSIS OF ALTERNATING CURRENT CIRCUITS, 76 pp.; Johns Hopkins Univ. Press, Baltimore.
- Levi-Civita, Tullio, 1929. THE ABSOLUTE DIFFERENTIAL CALCULUS, (Translated into English by Miss M. Long), 452 pp.; Blackie and Son Ltd., London and Glasgow.
- McConnell, A. J., 1936. APPLICATIONS OF THE ABSOLUTE DIFFERENTIAL CALCULUS, 2nd. Printing, 318 pp.; Blackie and Son Ltd., London.
- Magnusson, G. E., 1931. ALTERNATING CURRENTS, 4th. Ed., 685 pp.; McGraw-Hill Co., New York.
- Mallett, E., 1934. VECTORS FOR ELECTRICAL ENGINEERS, 181 pp.; Sherwood Press, Cleveland. (Whitefriars Press Ltd., London)
- Malti, M. G., 1930. ELECTRIC CIRCUIT ANALYSIS, 389 pp.; John Wiley and Sons, New York.
- Morecroft, J. H., and Hehre, F. W., 1924. ALTERNATING CURRENTS, (Vol. II of ELECTRIC CIRCUITS AND MACHINERY), 444 pp.; John Wiley and Sons, New York.
- Pen-tung Sah, A., Aug. 1936. DYADIC ALGEBRA APPLIED TO THREE-PHASE CIRCUITS, Elec. Engg., v. 55; p. 876-82.
- Pen-tung Sah, A., Dec. 1936. COMPLEX VECTORS IN THREE-PHASE CIRCUITS, Elec. Engg., v. 55; p. 1356-64.

- Pipes, Louis A., Sept. 1937. MATRICES IN ENGINEERING, Elec. Engg.  
v. 55; p. 1177-90.
- Shuck, G. R., Nov. 1935. EQUATIONS FOR CALCULATING SYMMETRICAL  
COMPONENTS, 26 pp., Univ. of Washington Press, Seattle.
- Slepian, J., Dec. 1936. PARABLE OF TENSOR ANALYSIS, Elec. Journal,  
v. 33; p. 541-47.
- Slepian, J., Mar. 1937. TENSORS AND FRUIT SALADS, Elec. Journal,  
v. 34; p. 115-19.
- Standard Handbook for Electrical Engineers, 1933, 6th. Ed.; Sec. 5,  
6, 7, 14, and 15; McGraw-Hill Co., New York.
- Steinmetz, C. P., April 1893. DISCUSSION ON PAPER BY KENNELLY,  
AIEE Trans. v. X; p. 227.
- Steinmetz, C. P., Aug. 1893. COMPLEX QUANTITIES AND THEIR USE IN  
ELECTRICAL ENGINEERING, Proceedings of the International  
Electrical Congress, Chicago; p. 33-76.
- Steinmetz, C. P., 1897. ALTERNATING CURRENT PHENOMENA, McGraw-Hill, N.Y.
- Steinmetz, C. P., 1916. THEORY AND CALCULATION OF ALTERNATING CURRENT  
PHENOMENA, 5th. Ed., 480 pp.; McGraw-Hill Co., New York.
- Steinmetz, C. P., 1917. THEORY AND CALCULATION OF ELECTRIC CIRCUITS,  
361 pp.; McGraw-Hill Co., New York.
- Thomas, T. Y., 1931. THE ELEMENTARY THEORY OF TENSORS WITH APPLICATIONS  
TO GEOMETRY AND MECHANICS, 122 pp.; McGraw-Hill Co., New York.
- Weinbach, M. P., 1933. ALTERNATING CURRENT CIRCUITS, 417 pp.;  
MacMillan Co., New York.

A WORD OF THANKS

I would like to express here my sincere appreciation of the many helps and kindly criticisms given me by members of my thesis committee, of the graduate committee, and by many others in connection with the preparation of this thesis.

Particularly do I wish to express my feeling of indebtedness to the late Prof. J. A. Thaler who suggested the subject material, and encouraged the preparation in a form which would be comprehensible by undergraduate engineering students; and to Prof. W. D. Fallman for his untiring efforts in connection with the development of the graphical presentation.

Amin J. Hill  
June, 1938

MONTANA STATE UNIVERSITY LIBRARIES  
  
3 1762 10014320 3

N378	60024
H55m	
cop. 2	
Hill, A.J.	
A method of graphical analysis for unsymmetrical three-phase circuits.	

N378	60024
H55m	
cop. 2	