



Air oxidation of chrome ore
by Robert L Gore

A THESIS Submitted to the Graduate Faculty in partial fulfillment of the requirements for the degree of Master of Science in Chemical Engineering at Montana State College
Montana State University
© Copyright by Robert L Gore (1961)

Abstract:

In 1956 Mouat Industries at Columbus, Montana commenced construction of a pilot plant for the production of sodium dichromate from the chrome ores available in the area near Nye, in southwestern Montana. This project, at Montana State College, was initiated for the purpose of aiding in the development of this pilot plant.

Since the air oxidation of the chrome ore concentrates proved to be the most difficult step, in the process, it was to this phase of the operation that the project at the College has been directed.

Chrome ore concentrates were blended with sodium carbonate and a recycle material. These feed mixtures were subjected to high temperatures (1800°F to 2200°F) in an oxidizing atmosphere for the purpose of converting the chromium in the ore (Cr_2O_3) to sodium chromate (Na_2CrO_4), a water soluble compound. A variety of feed blends, temperatures and retention times were explored.

High sodium carbonate content (22 weight percent) favored increased conversion. Although high recycle to fresh concentrates ratios increased the percent conversion, kiln capacity would suffer due to the decreased chromium content of these high ratio feeds. Conversion increased with temperature over the temperature range explored. Conversions increased rapidly with retention time up to a total of 30 to 45 minutes retention time. After 45 minutes, only a slight increase in conversion was attained.

Feeds containing a high percentage of sodium carbonate (22 percent), low recycle to concentrates ratio (approximately 2.0 or less) subjected to a high temperature (2200°F) for at least 30 to 45 minutes, appeared to yield the best over-all results for this type of feed.

The results of this study indicate that conversions in the range of 40 percent are the best that could be expected of kiln feeds comprised of sodium carbonate, recycle material and chrome ore concentrates only. Therefore, it is recommended that feeds of a different composition be investigated, such as various combinations of the above ingredients with lime, limestone or dolomite.

AIR OXIDATION OF
CHROME ORE

by

ROBERT L. GORE

A THESIS

Submitted to the Graduate Faculty

in

partial fulfillment of the requirements

for the degree of

Master of Science in Chemical Engineering

at

Montana State College

Approved:



Head, Major Department



Chairman, Examining Committee

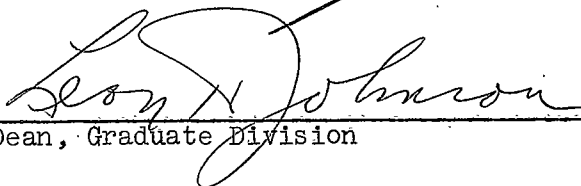

Dean, Graduate Division

Bozeman, Montana
September, 1961

~~XXXXXXXXXX~~
N378
C9666

TABLE OF CONTENTS

	Page
Abstract.	3
Introduction	4
Equipment Design and Operation	10
Feed Preparation	13
Results	15
Summary and Recommendations	25
Literature Consulted	26
Appendix	27

ABSTRACT

In 1956 Mouat Industries at Columbus, Montana commenced construction of a pilot plant for the production of sodium dichromate from the chrome ores available in the area near Nye, in southwestern Montana. This project, at Montana State College, was initiated for the purpose of aiding in the development of this pilot plant.

Since the air oxidation of the chrome ore concentrates proved to be the most difficult step in the process, it was to this phase of the operation that the project at the College has been directed.

Chrome ore concentrates were blended with sodium carbonate and a recycle material. These feed mixtures were subjected to high temperatures (1800°F to 2200°F) in an oxidizing atmosphere for the purpose of converting the chromium in the ore (Cr_2O_3) to sodium chromate (Na_2CrO_4), a water soluble compound. A variety of feed blends, temperatures and retention times were explored.

High sodium carbonate content (22 weight percent) favored increased conversion. Although high recycle to fresh concentrates ratios increased the percent conversion, kiln capacity would suffer due to the decreased chromium content of these high ratio feeds. Conversion increased with temperature over the temperature range explored. Conversions increased rapidly with retention time up to a total of 30 to 45 minutes retention time. After 45 minutes, only a slight increase in conversion was attained.

Feeds containing a high percentage of sodium carbonate (22 percent), low recycle to concentrates ratio (approximately 2.0 or less) subjected to a high temperature (2200°F) for at least 30 to 45 minutes, appeared to yield the best over-all results for this type of feed.

The results of this study indicate that conversions in the range of 40 percent are the best that could be expected of kiln feeds comprised of sodium carbonate, recycle material and chrome ore concentrates only. Therefore, it is recommended that feeds of a different composition be investigated, such as various combinations of the above ingredients with lime, limestone or dolomite.

INTRODUCTION

In 1956, Mouat Industries at Columbus, Montana commenced construction of a pilot plant for the production of sodium dichromate. The purpose of this venture was to provide a continuing use for the chrome ores available in the area near Nye, in southwestern Montana.

This project, at Montana State College, was initiated for the purpose of aiding in the development of the pilot plant at Columbus, and thereby increasing the utilization of Montana's natural resources.

The processing of the chrome ore, as done at Columbus, commences with the trucking of the ore from the Benbow mine at Nye down to the ore dump adjacent to the plant in Columbus. The ore is fed to a jaw crusher and then is introduced to the primary ball mill. The ore is ball milled wet. It is then passed over a wet table which separates the finely ground ore into three fractions. These three fractions are concentrates, middlings, and tailings. The middlings are recycled to the ball mill and the tailings slurried to the tailings dump. The concentrates from the table go to a secondary ball mill and then to the concentrates stockpile. The chromium in these concentrates, as Cr_2O_3 , will range from 32 to 38 weight percent.

The next step in the process is the batch mixing of the kiln feed ingredients to produce a feed slurry. The desired weights of concentrates, recycle material and sodium carbonate are introduced to the feed blending tank along with water. This feed slurry is continually

agitated in the tank and circulated through a ball mill. The feed slurry is pumped from the blending tank, as needed, to a small reservoir from which it is pumped into the rotary driers. This small reservoir can hold approximately 30 minutes' worth of drier feed and thus allow sufficient time for making up the succeeding batch of kiln feed slurry in the blending tank.

The co-current drying of the kiln feed slurry is accomplished in gas-fired rotary driers. These driers discharge a bone-dry kiln feed which is then stored in the kiln feed storage hopper. From the storage hopper, the feed is passed through a gas-fired rotary kiln. In the kiln the chromium in the ore is converted to sodium chromate at high temperature, in an oxidizing atmosphere. The hot kiln discharge is then augered into a leach tank where water dissolves the soluble sodium chromate along with the reacted aluminum, as sodium aluminate.

The leach tank product, an alkaline slurry, is then pumped to an acid addition tank where the alkalinity is reduced with sulfuric acid. When the pH reaches 9.0 to 9.5, the slurry is pumped from the acid addition tank to an Oliver filter where the water insoluble solids are separated from the liquor. The resulting liquor is an aqueous solution of sodium chromate and sodium aluminate. The solid cake from the filter is the recycle material consisting of iron as Fe_2O_3 , magnesium as MgO , unreacted chromium and aluminum as Cr_2O_3 and Al_2O_3 , respectively, as well as a small amount of entrained liquor.

Sufficient recycle material is stored for feed blending purposes. The remainder is discarded to the tailings dump after being slurried and passed over the wet table for the removal of the unreacted chrome values.

The liquor from the Oliver filter is now pumped back to the acid addition tank where the sulfuric acid is added until the pH is between 6.5 and 7.5. Under these conditions, the aluminum which was in solution as sodium aluminate, is insoluble and precipitates out as the hydroxide.

This suspension of chromate liquor and aluminum hydroxide is then drawn through leaf filters. The aluminum hydroxide cake is discarded, and the liquor is sent to the steam-jacketed evaporator via an atmospheric evaporator-storage tank. When the liquor has been boiled down to a specific gravity of 1.3, sufficient sulfuric acid is added to adjust the pH of the liquor to 5.3. By the addition of this acid, the chromate in the liquor is converted to sodium dichromate accompanied by the precipitation of sodium sulfate as crystals.

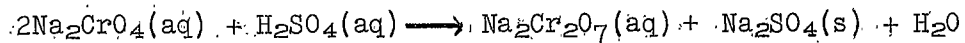

The resultant slurry is drained into agitated cooling tanks where the temperature is reduced from approximately 180°F to 95°F. The slurry is then fed to a centrifuge which separates the sodium sulfate crystals from the sodium dichromate liquor. The sodium sulfate is discarded and the dichromate liquor pumped to a second steam-jacketed evaporator

where the specific gravity is increased to 1.68 and the final pH adjustments are made.

The finished product is an aqueous solution of sodium dichromate, having a specific gravity of 1.68 and a pH of 4.7 to 5.1, and is marketed in this form.

The air oxidation of the chrome ore concentrates proved to be the most difficult step in the process. Therefore, it was to this phase of the plant operation that the project at the College has been directed.

This oxidation step is the first chemical reaction in the process. By this means, sodium carbonate and chromium, as chromic oxide, are reacted at high temperature in an oxidizing atmosphere to produce a water soluble compound, sodium chromate.

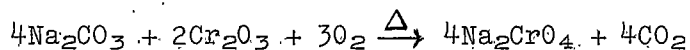

A small rotary kiln (see Figures 1 and 2, pages 33 and 34) was constructed for the purpose of investigating this step in the process. It was not possible to explore higher temperature ranges (above 1800°F) in the rotary kiln. This was due to the limitations of the materials of construction of the kiln. For this reason, a brick-lined muffle furnace was used to explore temperatures up to 2200°F.

In one respect the Columbus pilot plant is unique when compared to other dichromate producing plants. This difference in the Columbus

plant operation is the method of kiln feed preparation. While all other dichromate producers that the author has read about or heard of blend their kiln feed constituents dry, the Columbus plant operation uses a wet method. As far as is known, this wet method has not been proven to be superior to conventional dry mix procedures. This wet method necessitates drying a thin slurry down to a bone-dry powder which is stored and then metered into the kiln.

The supposed advantage of wet versus dry mixing procedures appears in the degree of intimacy of mixing of the feed ingredients. Theoretically, the dry method results in kiln feeds comprised of particles of sodium carbonate adjacent to concentrate and recycle particles. In contrast to this, the wet method would lead to particles of concentrate and recycle coated with sodium carbonate and thus in more intimate contact.

As either type of feed progresses through the kiln, the sodium carbonate melts. This occurs at 1564°F. As the kiln charge continues to heat up, the kiln rotation causes considerable agitation. When the charge has reached a reasonable reaction temperature, it is open to question if a significant increase in conversion percentages would be attained due to wet mixing over dry.

Oxygen must also be present in order for the desired reaction to take place. Therefore, a complete coating of fused sodium carbonate

surrounding the concentrate particles might inhibit the diffusion of the necessary oxygen. Thus, it is conceivable that wet mixing methods could lead to lower rather than higher conversion percentages.

In addition to laboratory experiments at the College, considerable time was spent working with the plant personnel in Columbus. This close association with the Columbus pilot plant operation led to several useful recommendations. These recommendations have helped, in part, to advance the Columbus plant to its present state of development. A fuller discussion of these recommendations may be found on page 15, in the Results section of this thesis.

EQUIPMENT DESIGN AND OPERATION

Kiln Design

A rotary kiln, ten feet in length, was constructed (see Figure 1, page 33). The kiln consisted of a center tube made of #304 stainless steel, 5/16-in. thick, and an outer shell of 1/8-in. mild steel. The inside diameter of the center tube was 15 inches, while the outer shell had a 36-in. diameter. The annular space between the center tube and outside shell was filled with vermiculite insulation. An expansion joint was provided in the burner end of the outside shell. A 3-in. diameter water-jacketed auger, equipped with a variable speed hydraulic reduction box, was used to meter the feed into the kiln. The kiln was supported by a stand made of 3-in. diameter boiler tubing. The stand was provided with screw jacks on the burner end to allow for adjustments in kiln pitch. Kiln rotation was powered through an Ohio Gear variable speed gear box and chain drive arrangement. The kiln exhaust manifold was fabricated from 3/32-in. #302 stainless steel. The manifold and feed mechanism were built as a unit, independent of the kiln stand. This provided for easy maintenance and clean-out. The manifold was connected to a 10-in. diameter stack, 25 feet high. The draft was throttled with a stainless steel damper placed between the manifold and the stack. The kiln was fired with natural gas through a B-type Denver Fire Clay inspirator burner. This type of burner inspirates its own primary air through a Venturi.

Temperature control was provided (see Figure 2, page 34) by a Minneapolis-Honeywell pneumatic control valve in conjunction with a Brown Instrument Company single point controller-recorder. The temperature sensing device was a Chromel-Alumel thermocouple placed in a stainless steel thermocouple well. This thermocouple assembly was mounted at the burner end of the kiln with the tip positioned just ahead of the burner flame, next to the kiln surface.

Kiln Operation

The burner was fired and kiln rotation as well as feed auger drives were turned on. The kiln was brought up to 1600°F with manual control using the valve and control valve bypass arrangement. The feed was then introduced to the feed auger hopper, and the temperature control was changed to the automatic controller. The temperature was then increased until 1800°F was indicated on the controller. This was the temperature setting for all kiln runs. Approximately 40 minutes after starting the feed delivery, the kiln charge was distributed throughout the length of the kiln. At this point, the operation was considered lined out.

Samples of the discharging kiln product were taken one hour after the kiln operation was lined out. Three such samples were taken for analysis, each spaced 25 minutes apart. The average retention time was determined by dividing the weight of the total charge in the kiln by the discharge rate. The discharge rate was obtained by weighing the amount of discharging product collected during a 10-minute period

for each run. At the end of several runs the total kiln load was discharged and weighed. By a visual estimate, the proportion of non-moving material in the kiln seemed to be between 15 and 30 percent of the total kiln charge. Therefore, the calculated retention time was adjusted accordingly. The speed of rotation for all kiln runs was 1.5 rpm.

Muffle Design and Operation

A model 1220 Denver Fire Clay Company muffle furnace was used for all muffle runs. The necessary oxidizing atmosphere was obtained by introducing air through a 3/4-in. diameter quartz tube placed through an aperture in the muffle door. The temperature was controlled manually with the gas line valve and burner air valve. A Brown Instrument potentiometer in conjunction with a Chromel-Alumel thermocouple probe, was used to read temperatures. It was possible to control the temperature inside the muffle to within ten Fahrenheit degrees, except while removing samples.

The samples were placed on brick pallets in the cold muffle furnace and allowed to warm up to the desired temperature. The air supply was then turned on, and retention times measured from this point.

FEED PREPARATION

The feeds blended for this study are comprised of three ingredients in varied proportions.

1. Chrome ore concentrates from the Benbow mine, Stillwater County, Montana.
2. Sodium carbonate (Na_2CO_3) as supplied by Westvaco, a division of Food Machinery Corporation at Green River, Wyoming.
3. Recycle material as derived from the operation of the Mouat Industries plant in Columbus, Montana.

These materials were donated by Mouat Industries of Columbus, Montana.

A complete analysis of all the constituents in the concentrates used in this study was not available. However, some idea of the composition of the concentrates obtained from the Stillwater complex is shown below.

Fe	16.35%	MgO	15.80%
SiO ₂	6.88%	CaO	0.20%
Al ₂ O ₃	15.82%	Cr ₂ O ₃	38.50%

The above analysis was obtained from Dr. Dwight Harris of the American Chrome Company at Nye, Montana. It is a monthly concentrate composite sample analysis of the concentrates being produced by American Chrome Company under government contract.

The chrome ore concentrates were ball milled for 2.5 hours to 100 percent through a 200-mesh screen. The sodium carbonate was a fine powder and used as such. The recycle material, which is the solids

cake obtained after leaching the kiln product in water, was washed clean of water soluble materials (unreacted sodium carbonate and sodium chromate). This was done in 55-gallon open-topped drums by successive slurring, settling and decanting with water. The resulting thick slurry was then run through a small laboratory Oliver filter to produce a wet cake. This wet cake was completely dried in the rotary kiln at 300 to 500°F. The dried cake was ball milled in approximately 30-pound batches for 30 minutes to produce a fine powder.

The kiln feed was blended in a steam-jacketed copper kettle. Fifteen-pound steam was supplied to the kettle which was fitted with a stirrer. The weighed sodium carbonate was poured into 8 to 10 gallons of water and sufficient time allowed for complete solution. The desired chrome concentrates followed by the recycle material were weighed into the sodium carbonate solution. The resulting slurry was agitated and boiled down to the consistency of thick fudge, removed and dried completely in the rotary kiln at 300 to 500°F. The dried feed cake was then ball milled in 30-pound batches for 30 minutes to reduce it to a fine powder.

Since only two kilograms of each feed blend was needed for the muffle study, the blending was done in the same manner as for the kiln feeds, but with bench scale equipment.

RESULTS

The results of this thesis are the outcome of experiments in the laboratory as well as experiences gained from a close association with the Columbus plant operation.

Rotary Kiln and Muffle Furnace Runs

Sixteen kiln runs were completed for this thesis. These runs (see Table I, page 28) were designed to explore the effects of feed composition on conversion. The two variables of feed composition of interest in this study are the sodium carbonate content and the ratio of recycle material to fresh ore concentrates. The operating conditions common to these runs are listed below.

Temperature-----	1800°F
Kiln rotation-----	1.5 rpm
Kiln pitch-----	1/8-in. per foot
Retention time-----	80 minutes

Figure 3 on page 35, indicates a negligible increase in conversion due to an increased weight ratio of recycle to concentrates. Figure 4 on page 36 illustrates a somewhat greater increase in conversion due to increased sodium carbonate content in the feed, when compared to the effect of increasing the proportion of recycle material. All conversions were low for the kiln runs, ranging from 6.2 to 20.2 percent. The lowest conversion resulted from low sodium carbonate content and low recycle to concentrates weight ratio. The highest conversion was obtained with the highest sodium carbonate content (21 weight percent) and highest

ratio of recycle to concentrates (3.0).

Figure 5 on page 37 depicts the temperature profile throughout the length of the kiln. This plot shows that the kiln charge is above 1600°F for about two feet of kiln length. Assuming the charge is equally distributed throughout the length of the kiln, during only one-fifth of the retention time (approximately 16 minutes) would the kiln charge be above 1600°F. At 1800°F, Figure 5 shows only a momentary residence time. This condition is undoubtedly responsible, at least in part, for the overall low conversions attained in the rotary kiln.

A total of 30 runs were made in a muffle furnace in order to investigate the effect of temperatures above 1800°F as well as extended retention time. These muffle runs serve to indicate the limitations of the type of feed blends used throughout this study.

The three different feed blends which were employed in the muffle study are listed below (see Tables II, III and IV on pages 29, 30, and 31, respectively).

<u>Weight Percent</u> <u>Na₂CO₃</u>	<u>Weight Ratio</u> <u>of Recycle to</u> <u>Concentrates</u>
20	2.0
22	2.0
17	3.0

The moderate increase in conversion with increased temperature, which was obtained with both the 20 and 22 weight percent Na_2CO_3 feeds, is plotted in Figure 6, page 38, and Figure 7, page 39. The increased temperatures effect a noteworthy increase in conversion at the lower retention time only (15 minutes). This is true for both the 20 and 22 percent Na_2CO_3 feeds. A definite tapering off of increase in conversion as temperature approaches 2200°F is evident from these plots.

Reference to Figures 8 and 9, on pages 40 and 41, respectively, serve to illustrate the effect of retention time on feeds containing 20 and 22 percent Na_2CO_3 . All increase in conversion percentages level off markedly after 30 minutes. This is true for all temperature levels examined. This trend is slightly more pronounced with 20 percent Na_2CO_3 feeds than the 22 percent material. Reference to Figure 10 on page 42 serves to emphasize this tendency. The maximum conversion attained in any of these runs was 42.2 percent. This conversion was obtained in the muffle furnace at 2200°F for 75 minutes with a feed containing 22 weight percent Na_2CO_3 and a recycle to concentrates weight ratio of 2.0.

One additional muffle sample was run. This sample contained no concentrates, only recycle material mixed with sodium carbonate (22 weight percent). A conversion of 53.2 percent was attained with this sample. The operating conditions were 2000°F and 75 minutes retention time (see Table V, page 32).

Plant Modifications

Many of the problems involved in the operation of the Columbus plant have been solved due to recommendations made by the author. Most of these modifications fall into two classes: 1) process control improvement, and 2) prevention of material losses.

Process Control Improvement: The plant personnel had very poor control over the kiln temperature, since this was attempted manually with the aid of a visual pyrometer. The installation of a Minneapolis-Honeywell single point controller-recorder with accompanying control valves and sensing devices was recommended. This was immediately installed and provided automatic temperature control with five to ten Fahrenheit degrees.

No effort was being made to insure that feeds of constant and known composition were being fed to the kiln. Therefore, it was suggested that all materials (exclusive of the water) be carefully weighed into the feed mixing tank and a record of this be kept by each shift foreman. This change was introduced and shift personnel so instructed.

The rotary driers and accompanying pumps and lines were a constant source of trouble. This equipment all too often caused the kiln operation to be interrupted with a resultant loss of production. This problem was discussed with plant personnel and led to the recommending of a feed storage bin capable of holding several hours' worth of kiln feed. This bin has now been installed and equipped with a variable speed auger

arrangement. It is now possible to operate the kiln for long periods without interruption due to erratic drier operation.

Prevention of Material Losses

The bulk of the dusting at the Columbus plant is due to the drier operation. Most of the dust was being collected in a makeshift bag house but not being returned to the process. However, at one time it was being sent back to the feed mixing tank. Since this material is nothing more than kiln feed, it was recommended that it be routed directly to the kiln via the new feed storage bin.

Efforts had been made to replace the makeshift bag house with an American Blower Company cyclone. This cyclone caused considerable trouble both through questionable efficiency and mechanical failure. This condition led to the recommendation for the construction and installation of a large bag house with provision to convey the collected material back to the kiln feed bin. This has been completed and is handling the dust collecting satisfactorily.

The practice of periodically discarding recycle cakes had been carried on without any attempt to recover the unreacted chrome values contained in these cakes. These cakes would range up to twenty percent in chromic oxide content, depending upon operating conditions. Since the necessary equipment was available within the plant, the author suggested slurring this recycle material and passing the slurry over the wet table to separate the chrome-rich fraction for return to the

process. This has been tried and works quite well.

Recommended Relocation of Ore Concentrating Equipment:

At the present time, the ore is being transported by truck from the ore stockpile at the Benbow mine, located some fifty miles from the plant at Columbus. The author inquired about the availability of the necessary water and power for the operation of a small concentrating plant at the Benbow stockpile area. Since the plant personnel are sure that adequate water and power are available, it was recommended that the ore-concentrating portion of the plant be relocated at the mine area. This change will benefit the plant operation in two ways:

1) the necessary trucking of material will be reduced to approximately one-third of what it has been, and 2) the tailings cut from the ore will be disposed of up at the mine area, thereby reducing the maintenance and expansion of the existing tailings dump located at the plant in Columbus.

This recommendation has not, as yet, been acted upon. However, the plant personnel plan on completing this modification as soon as more pressing problems at the plant are dealt with.

SUMMARY AND RECOMMENDATIONS

The feed blends studied for this thesis contained three ingredients in varied proportions. These three ingredients were sodium carbonate, recycle material, and chrome ore concentrates. The effects on conversion of four factors were considered. These factors are:

1. Weight percent sodium carbonate
2. Weight ratio of recycle material to chrome ore concentrates
3. Temperature
4. Retention time

The first two of these factors were explored by operating the rotary kiln with various feed blends. The remaining two factors were investigated with the use of a muffle furnace.

Weight Percent Sodium Carbonate

Increased sodium carbonate content was responsible for the majority of the conversion increases due to feed blending. Udy (4) states that sodium carbonate content should be restricted to 22 weight percent, due to the tendency of the kiln charge to stick or hang up on the kiln wall. This stickiness is due to fused sodium carbonate. Although the maximum sodium carbonate content used in the kiln study was 21 percent, it was observed that less balling and sticking occurred with the high sodium carbonate feeds (greater than 17 weight percent). In view of the results it is recommended that future investigations be restricted to feeds containing at least 21 weight percent sodium carbonate.

Weight Ratio of Recycle Material to Chrome Ore Concentrates

At the operating conditions used (1800°F and 80 minutes retention time), increased proportion of recycle material has but minor effect on percent conversion. Considering the corresponding reduction in kiln throughput with respect to chromium content, it is recommended that future studies be restricted to feeds containing somewhat lower ratios.

Temperature Effects

The effects of temperature on conversion were evaluated with a muffle furnace. Since an increase in conversion was obtained with increased temperature throughout the temperature range explored (1800 to 2200°F), it is recommended that further study place emphasis on the upper end of this temperature range and above.

Retention Time

An evaluation of retention time was obtained with the aid of the muffle furnace. The results show that retention times of 30 to 45 minutes accomplish the bulk of the conversion and that additional time derives diminishing returns. This condition suggests that future studies be restricted to relatively short retention times (under one hour), and that longer retention times would be of limited value.

Limitations on Percent Conversion

The results of this thesis indicate that conversions in the range of 40 percent are the best that could be expected of kiln feeds comprised

of sodium carbonate, recycle material and chrome ore concentrates only.

This apparent maximum conversion could be due to:

1. Insufficient temperature or retention time
2. Chromium content of the recycle material being incapable of reacting with sodium carbonate
3. Depletion of the sodium carbonate

Insufficient Temperature or Retention Time:

The effects of increased temperature and retention time, as indicated in the results, tend to diminish at the upper limits of the ranges investigated. Therefore, a lack of retention time or insufficiently high temperature are apparently not the limiting factors.

Recycle Chromium Incapable of Reacting:

It may be argued that only the chromium which originated in the fresh concentrates is capable of reacting, and thus limiting the maximum conversion possible to some low value, in this case 40 percent. If this were true, any insoluble chromium present in the recycle material would be lost as far as conversion to sodium chromate is concerned. A 53.2 percent conversion was attained with the sample containing recycle material and sodium carbonate only. This demonstrates that both the chromium in the recycle material as well as that in the concentrates can be reacted. Thus, it is not the chromium which limits the possible conversion to 40 percent, but probably the consumption of the sodium carbonate.

Depletion of Sodium Carbonate:

The consumption of the sodium carbonate prior to the conversion of all of the chromium in the kiln charge appears to be the most likely cause of the limit on the percent conversions attained in this study. Sodium carbonate is not only consumed by the reaction with chromic oxide, but also through reaction with the alumina and silica present in the concentrates. Higher conversions should then be possible if some or all of the alumina and silica were removed from the kiln charge. This appears to be the case, since the highest percent conversion obtained was with the sample containing only recycle material in addition to the sodium carbonate.

Disposition of Chromium in the Process:

The continual introduction of fresh concentrates to the process results in a steady production of recycle material. Some of this recycle material is used in feed blending, while the remainder is discarded. In order to minimize the loss of chromium, the discard recycle material is slurried and passed over a wet table. The tabling of this recycle material can reduce the chromium content down to three percent in the discard. This is in accordance with results obtained at the plant in Columbus. The recovered chromium-rich fraction is returned to the process via the concentrates stockpile.

Excluding mechanical losses, it may be concluded that it is possible to convert all of the chromium present in the ore to sodium chromate.

Recommendations For Further Study:

Udy (4) mentions that lime is another material often employed in roasting mixes. Its use, as either burned lime (CaO) or hydrated lime (Ca(OH)_2) effects economies through inhibiting the reaction of sodium carbonate with the alumina present in the ore. It is also said that the presence of lime improves the physical characteristics of the roasting mixture. Udy also mentions that the use of dolomite in the roasting mixture is a possibility. McBerty (1), in listing a process outline for a German dichromate plant, indicates a third roast having 50 percent dolomite content. McBerty also describes a German process using quick lime. However, he also mentions that the overall plant recovery of chromium is 82 percent, the majority of the losses being due to the formation of calcium chromate.

Generally speaking, the use of lime or some other diluent is more often than not employed in roasting mixtures. According to Udy (4), limestone as such is not entirely satisfactory for this purpose. He fails to mention why. Limestones will generally contain between 5 and 14 percent silicon as SiO_2 . Since silicon is an undesirable constituent in roasting mixtures, this is probably the principal objection to raw limestone.

In summing up, it is recommended that feeds containing various proportions of lime or dolomite should be investigated.

LITERATURE CONSULTED

1. McBerty, Ford H., and Wilcoxon, B. H., "Bichromates Manufacture", Technical Industrial Intelligence Branch, U. S. Department of Commerce Flat Final Report No. 796. 1946.
2. Perry, John H., "Chemical Engineers' Handbook", McGraw-Hill Book Co., Inc., New York, 1950.
3. Scott, Wilfred W., "Standard Method of Chemical Analysis", D. Van Nostrand Co., Inc., Princeton, N. J., 1939.
4. Udy, Marvin J., "Chromium" (Volume I, Chemistry of Chromium and Its Compounds), Reinhold Publishing Corporation, New York, 1956.
5. Van Denburg, J. F., "Technical Service Report" (Mouat Industries, Inc., - Columbus, Montana), by Intermountain Chemical Company, Green River, Wyoming, Oct. 1959.

APPENDIX

	Page
Table I Kiln Run Composition and Conversion Data	28
Table II Muffle Sample Data -- 20 Weight Percent Sodium Carbonate	29
Table III Muffle Sample Data -- 22 Weight Percent Sodium Carbonate	30
Table IV Muffle Sample Data -- 17 Weight Percent Sodium Carbonate	31
Table V Special Muffle Sample	32
Figure 1 Laboratory Rotary Kiln	33
Figure 2 Kiln Temperature Control System	34
Figure 3 Plot of Conversion vs. Weight Ratio of Recycle to Concentrates For Rotary Kiln Samples	35
Figure 4 Plot of Conversion vs. Weight Percent Na_2CO_3 For Rotary Kiln Samples	36
Figure 5 Plot of Temperature vs. Position Down Length of Rotary Kiln	37
Figure 6 Plot of Conversion vs. Temperature For Muffle Samples Containing 20 Weight Percent Na_2CO_3	38
Figure 7 Plot of Conversion vs. Temperature For Muffle Samples Containing 22 Weight Percent Na_2CO_3	39
Figure 8 Plot of Conversion vs. Retention Time For Muffle Samples Containing 20 Weight Percent Na_2CO_3	40
Figure 9 Plot of Conversion vs. Retention Time For Muffle Samples Containing 22 Weight Percent Na_2CO_3	41
Figure 10 Plot of Conversion vs. Retention Time For Muffle Samples Containing 17 Weight Percent Na_2CO_3	42
Analytical Procedures	43

TABLE I

KILN RUN COMPOSITION AND CONVERSION DATA

Run No.	Weight Ratio Recycle to Concentrates	Weight Percent Na ₂ CO ₃	Percent		
			Total Chrome	Soluble Chrome	Conversion
1	1.5	15	24.4	1.69	6.9
2	2.0	15	22.1	1.38	6.2
3	2.5	15	21.3	1.49	7.0
4	3.0	15	20.4	2.01	9.9
5	1.5	17	23.6	2.36	10.0
6	2.0	17	22.1	2.50	11.3
7	2.5	17	21.5	2.53	11.8
8	3.0	17	20.8	2.77	13.4
9	1.5	19	21.5	2.69	12.5
10	2.0	19	20.7	2.94	14.2
11	2.5	19	20.9	2.82	13.5
12	3.0	19	19.3	3.06	15.8
13	1.5	21	22.7	3.46	15.2
14	2.0	21	21.5	4.17	19.4
15	2.5	21	21.4	4.06	19.0
16	3.0	21	20.7	4.17	20.2

TABLE II

MUFFLE SAMPLE DATA

Weight Percent Na_2CO_3	Retention Time in Minutes	Temperature in °F	Weight Ratio Recycle to Concentrates	Percent		
				Total Chrome	Soluble Chrome	Conversion
20	15	1800	2.0	18.9	3.78	20.0
20	30	1800	2.0	18.9	5.80	30.7
20	75	1800	2.0	18.9	6.83	36.2
20	15	2000	2.0	18.9	5.52	29.2
20	30	2000	2.0	18.9	6.10	32.3
20	75	2000	2.0	18.9	7.50	39.7
20	15	2100	2.0	18.9	6.07	32.2
20	30	2100	2.0	18.9	6.78	35.9
20	75	2100	2.0	18.9	7.45	39.4
20	15	2200	2.0	18.9	6.58	34.8
20	30	2200	2.0	18.9	7.41	39.2
20	75	2200	2.0	18.9	7.22	38.2

TABLE III

MUFFLE SAMPLE DATA

Weight Percent Na ₂ CO ₃	Retention Time in Minutes	Temperature in °F	Weight Ratio Recycle to Concentrates	Percent		
				Total Chrome	Soluble Chrome	Conversion
22	15	1800	2.0	19.1	3.95	20.6
22	30	1800	2.0	19.1	6.26	32.7
22	75	1800	2.0	19.1	6.97	36.4
22	15	2000	2.0	19.1	5.65	29.5
22	30	2000	2.0	19.1	6.69	34.9
22	75	2000	2.0	19.1	7.69	40.1
22	15	2100	2.0	19.1	5.94	31.0
22	30	2100	2.0	19.1	6.51	34.0
22	75	2100	2.0	19.1	7.30	38.1
22	15	2200	2.0	19.1	6.29	32.8
22	30	2200	2.0	19.1	7.07	37.0
22	75	2200	2.0	19.1	8.07	42.2

TABLE IV

MUFFLE SAMPLE DATA

Weight Percent Na ₂ CO ₃	Retention Time in Minutes	Temperature in °F	Weight Ratio Recycle to Concentrates	Percent		
				Total Chrome	Soluble Chrome	Conversion
17	15	2000	3.0	20.7	5.38	26.0
17	75	2000	3.0	20.7	6.30	30.4
17	180	2000	3.0	20.7	6.66	32.1
17	15	2100	3.0	20.7	5.74	27.7
17	75	2100	3.0	20.7	6.54	31.6
17	180	2100	3.0	20.7	6.54	31.6

TABLE V

SPECIAL MUFFLE SAMPLE

Weight Percent Na_2CO_3	22
Weight Percent Recycle Material	100
Weight Percent Concentrates	0
Temperature, °F	2000
Retention Time in Minutes	75
Percent Conversion	53.2

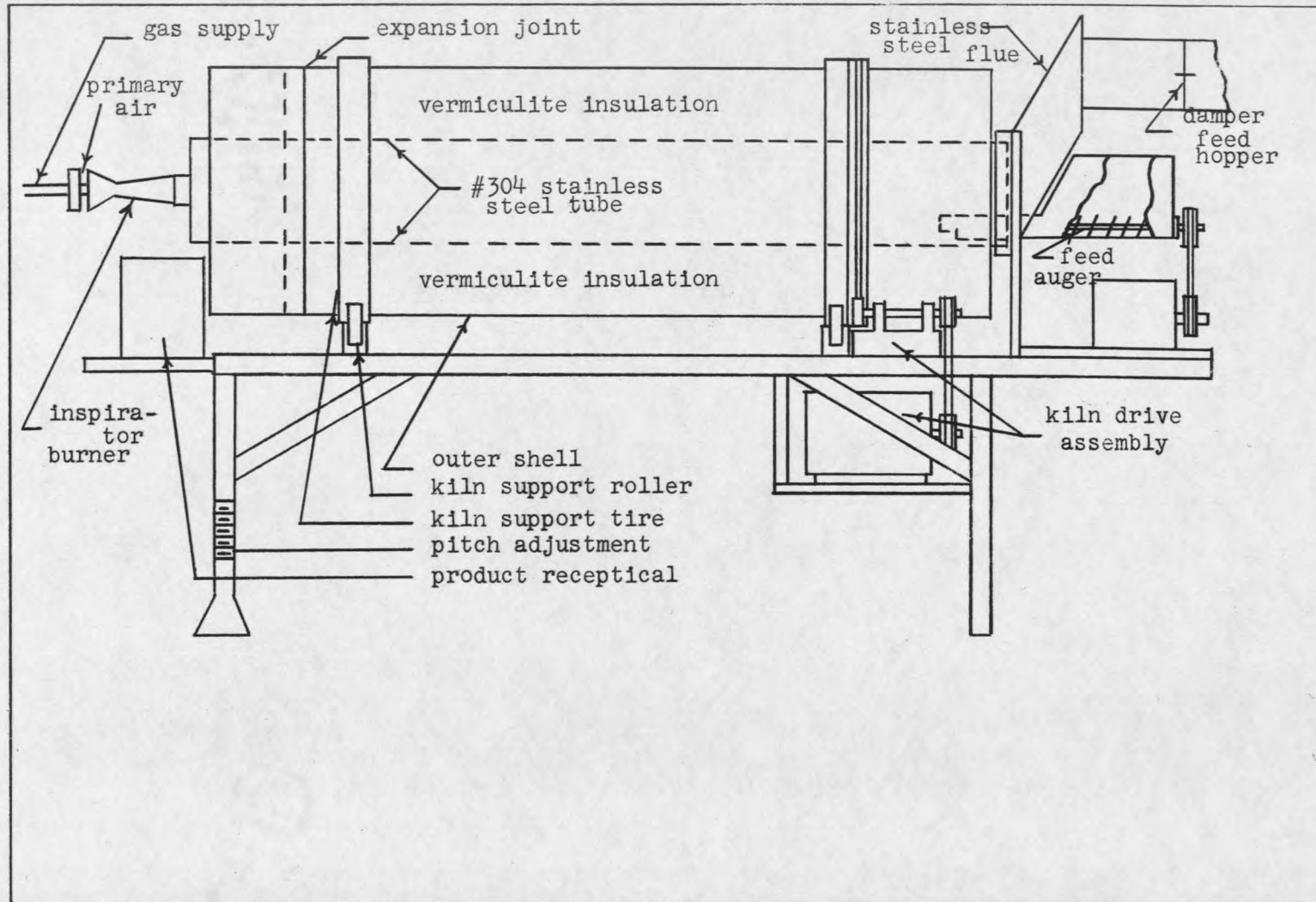

Figure 1. Laboratory Rotary Kiln

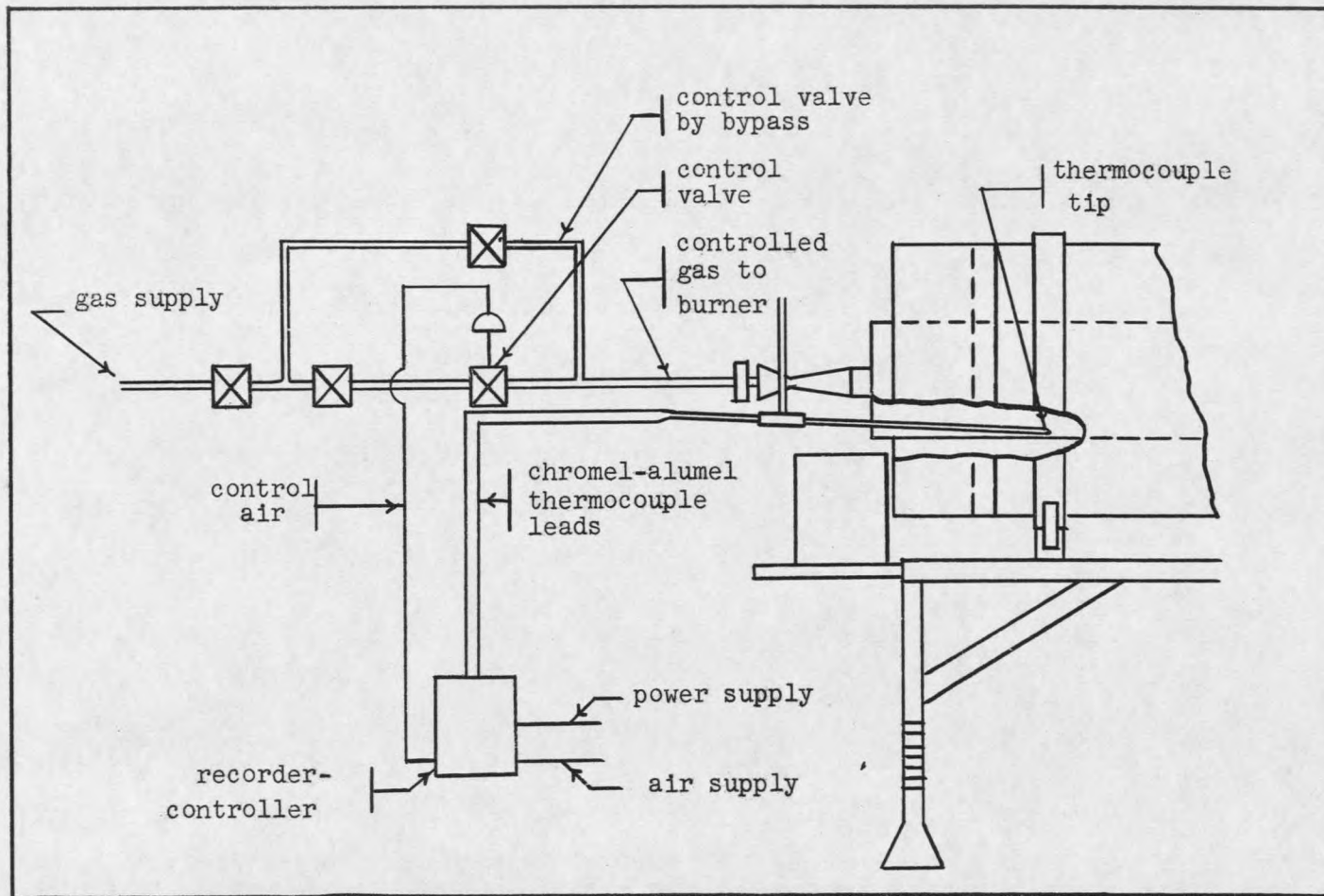

Figure 2. Kiln Temperature Control System

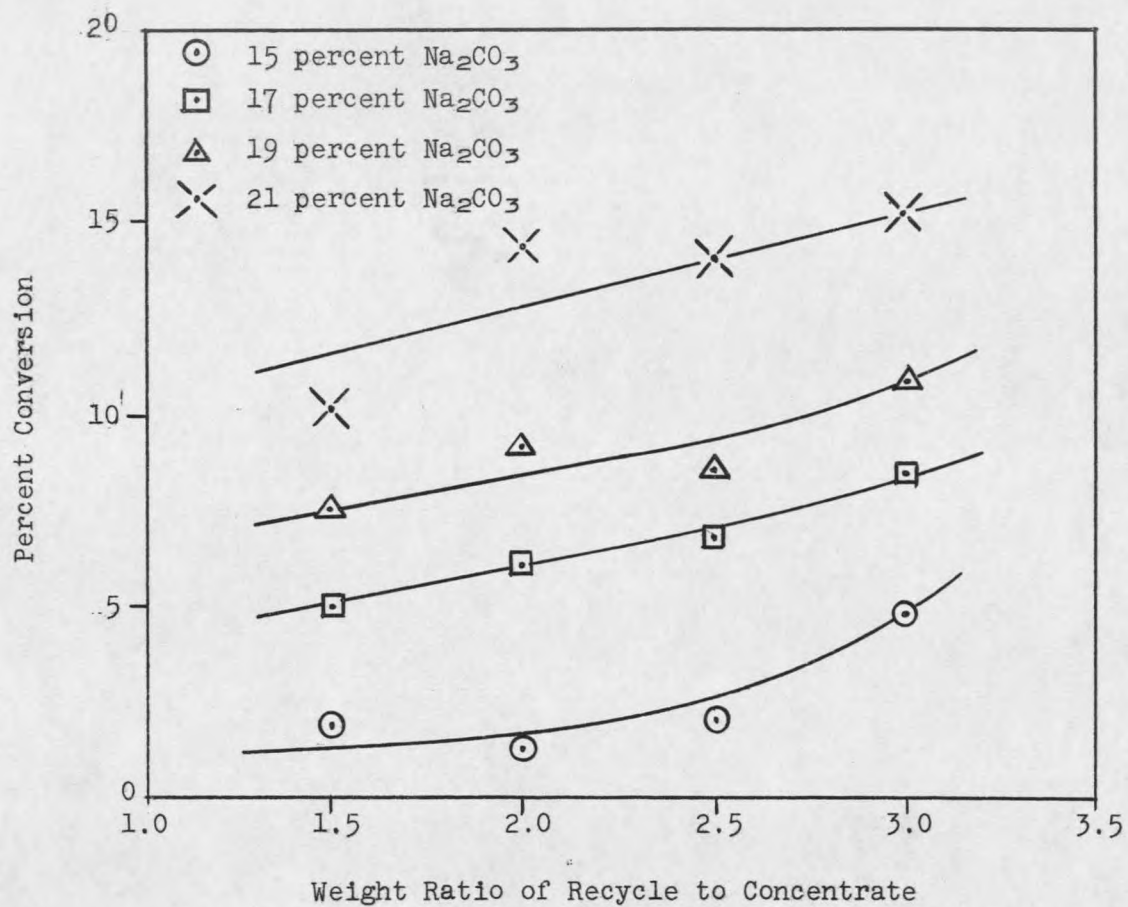

Figure 3. Plot of Conversion vs. Weight Ratio of Recycle to Concentrates for Rotary Kiln Samples

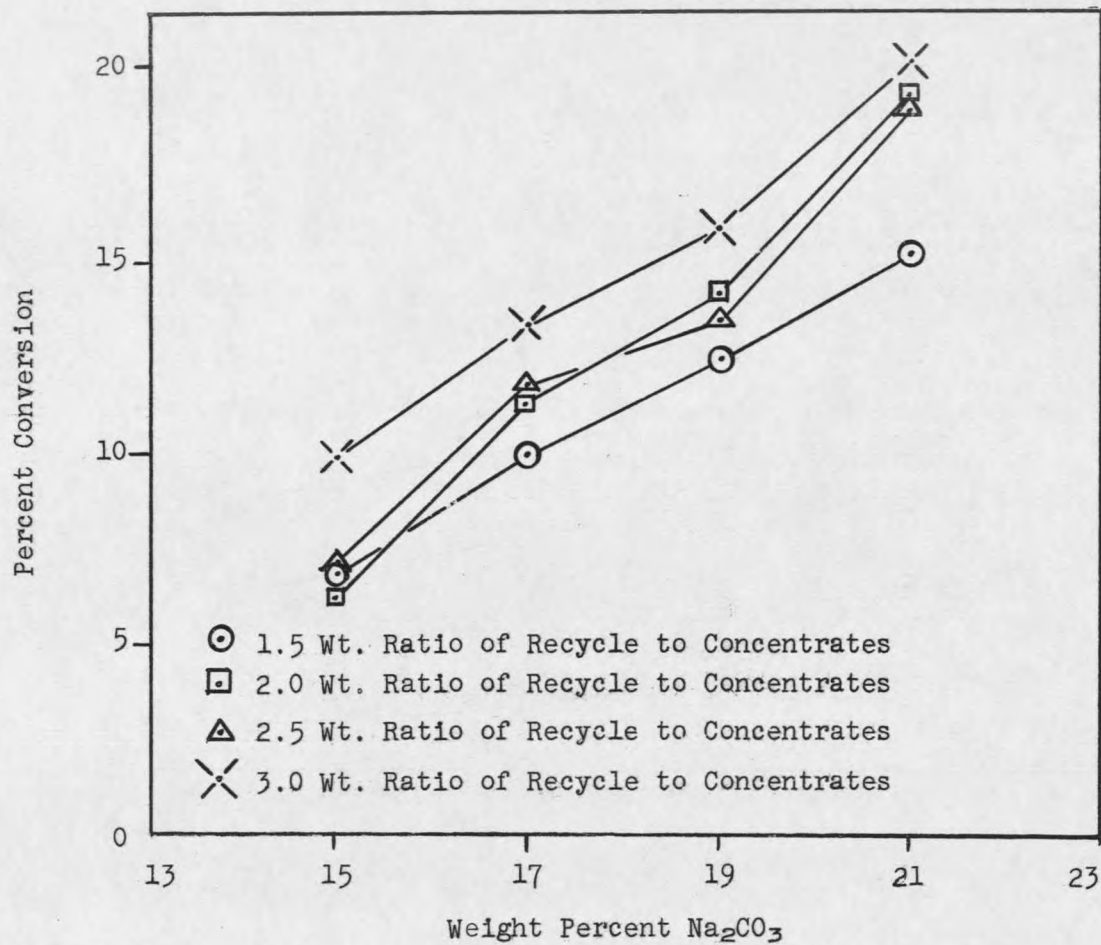
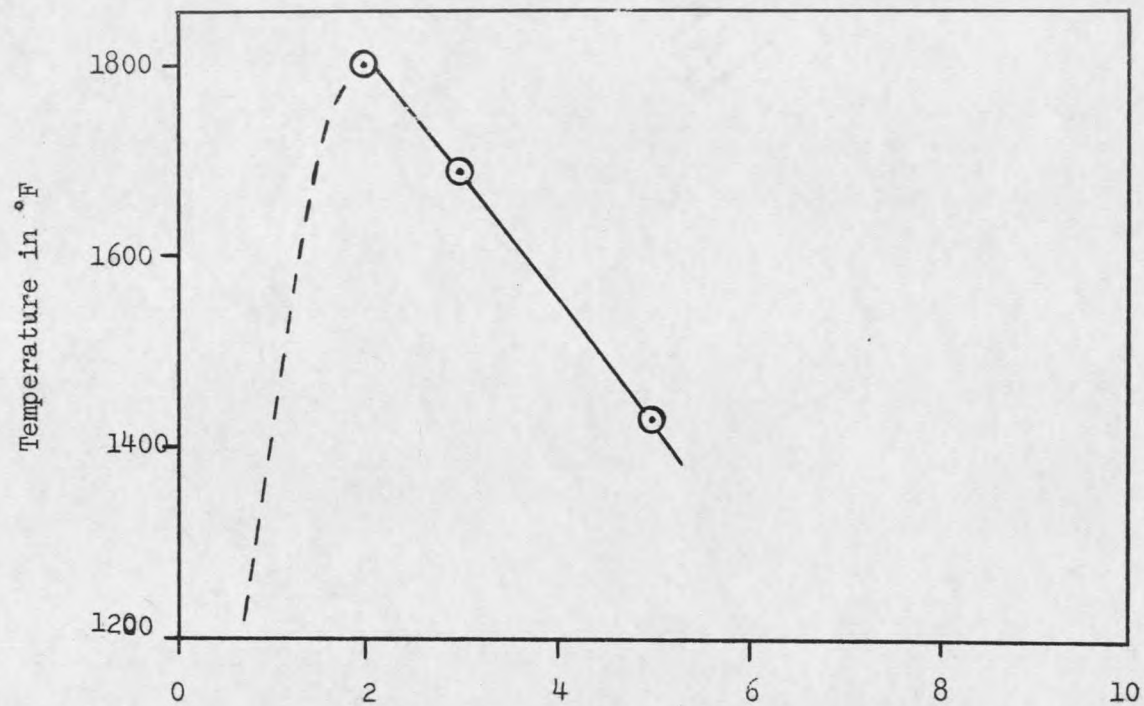

Figure 4. Plot of Conversion vs. Weight Percent Na_2CO_3 for Rotary Kiln Samples



Distance in Feet Down Tube Measured From Burner End of Kiln

Figure 5. Plot of Temperature vs. Position Down Length of Rotary Kiln

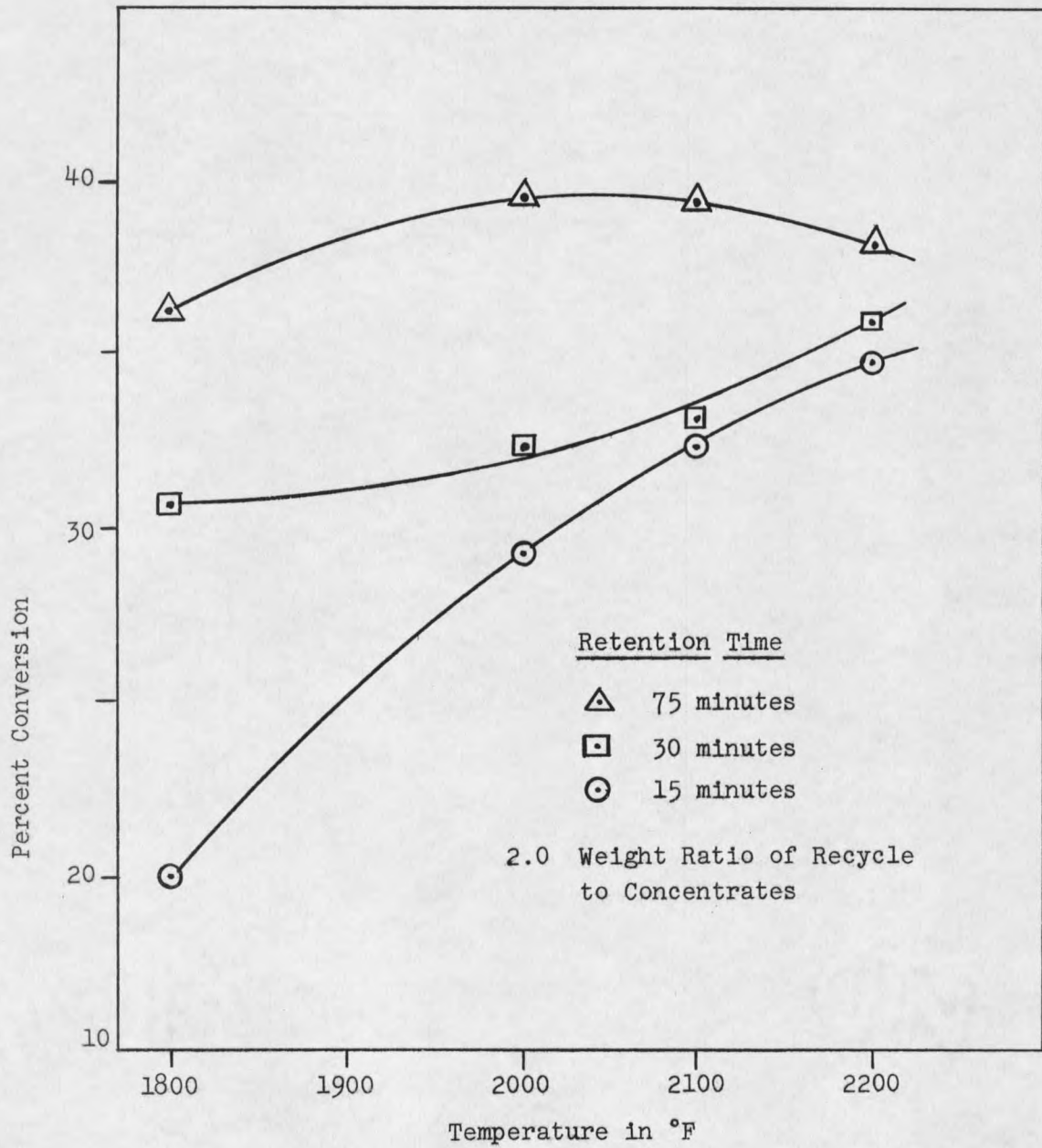

Figure 6. Plot of Conversion vs. Temperature for Muffle Samples Containing 20 Wt.% Na_2CO_3

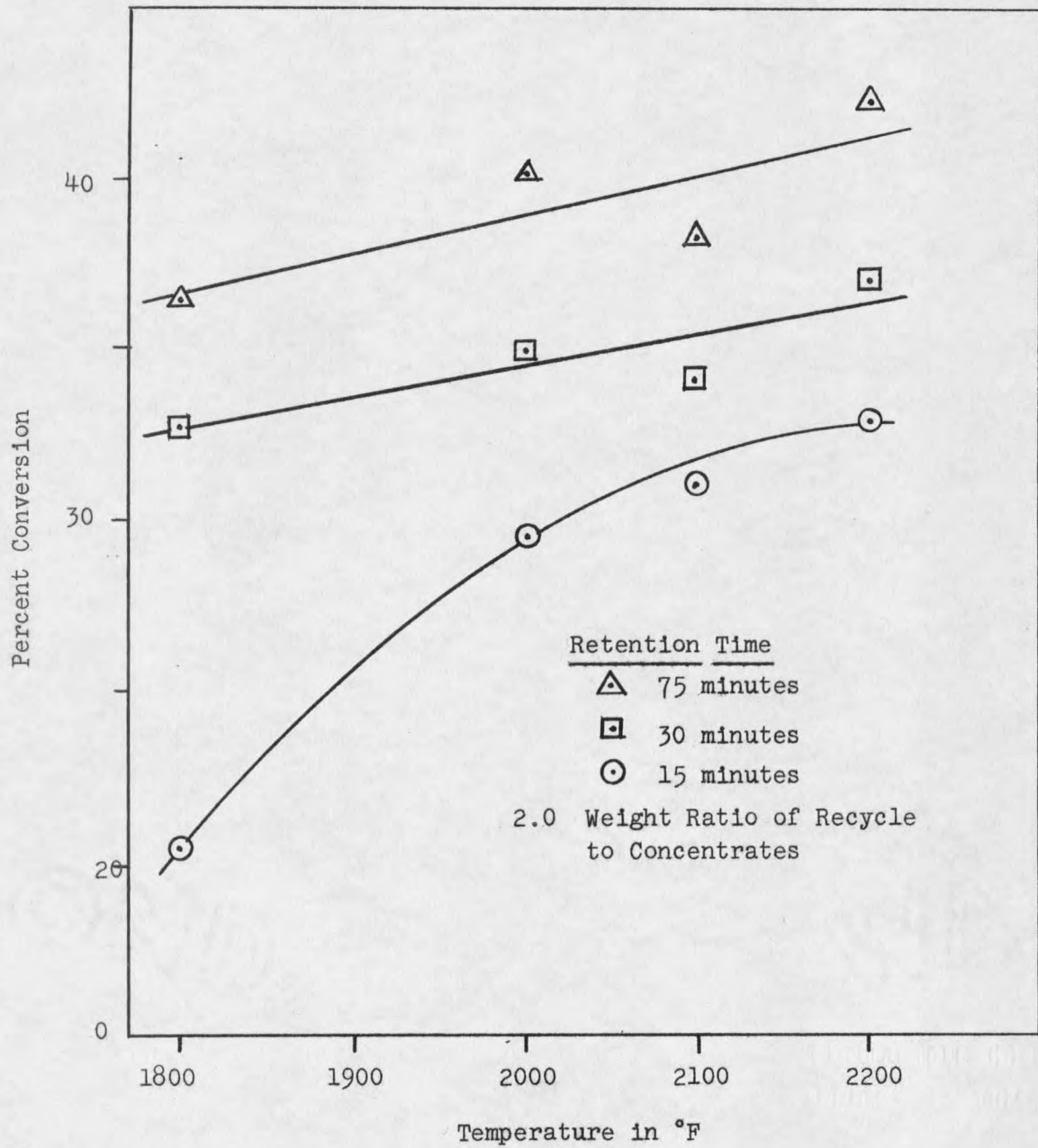

Figure 7. Plot of Conversion vs. Temperature for Muffle Sample Containing 22 Wt.% Na_2CO_3

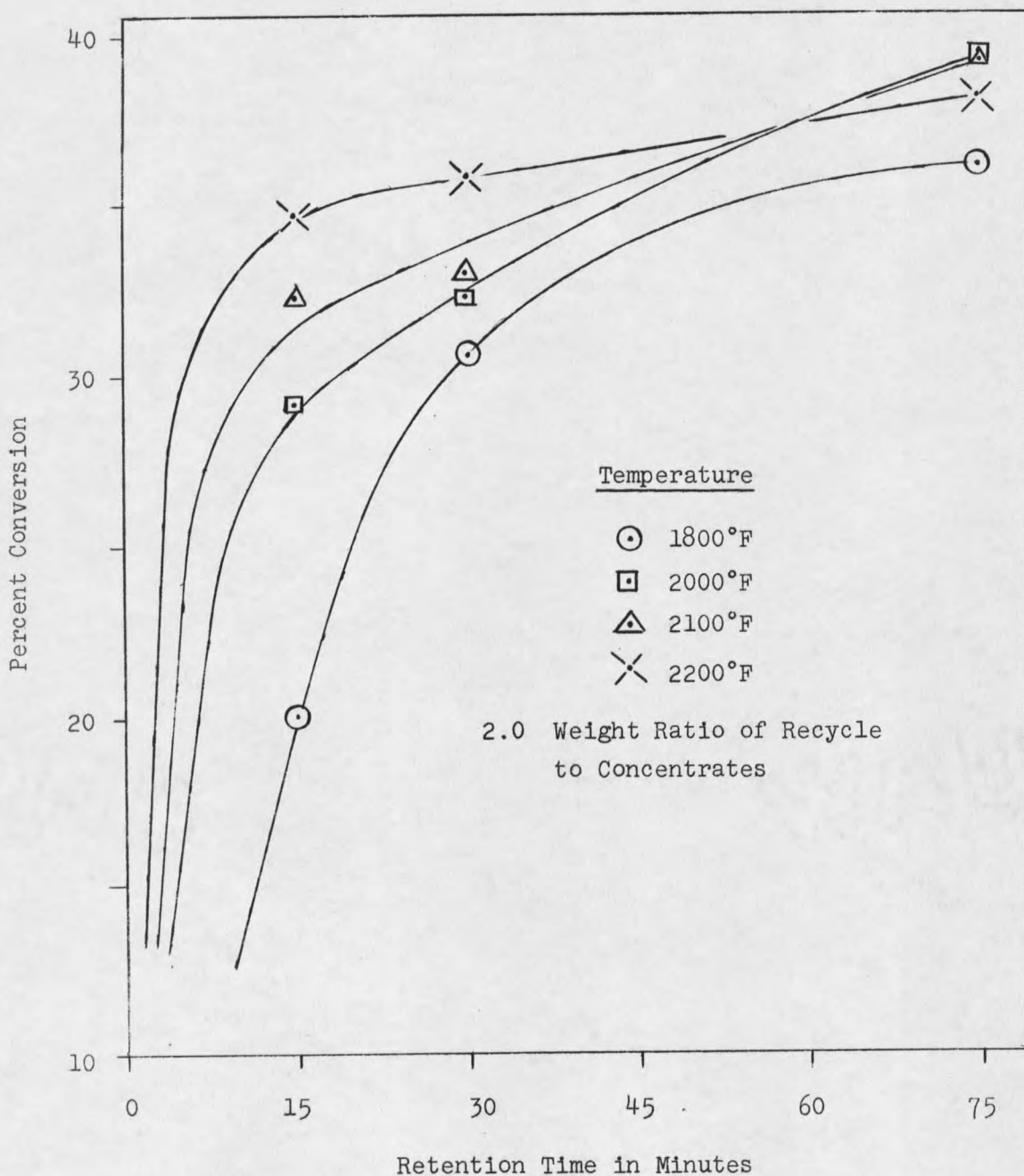

Figure 8. Plot of Percent Conversion vs. Retention Time for Muffle Samples Containing 20 Wt.% Na_2CO_3

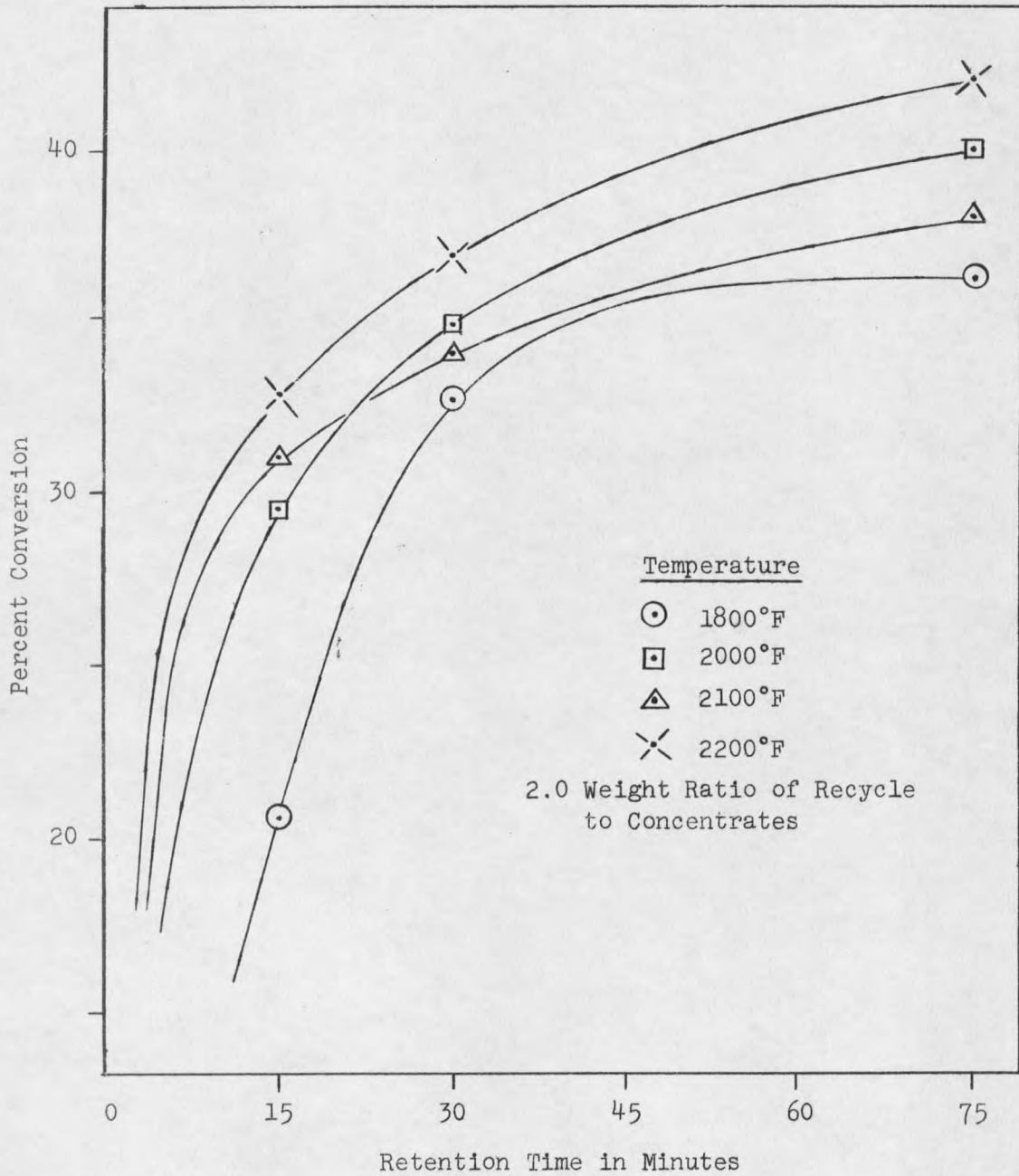

Figure 9. Plot of Percent Conversion vs. Retention Time for Muffle Samples Containing 22 Wt.% Na_2CO_3

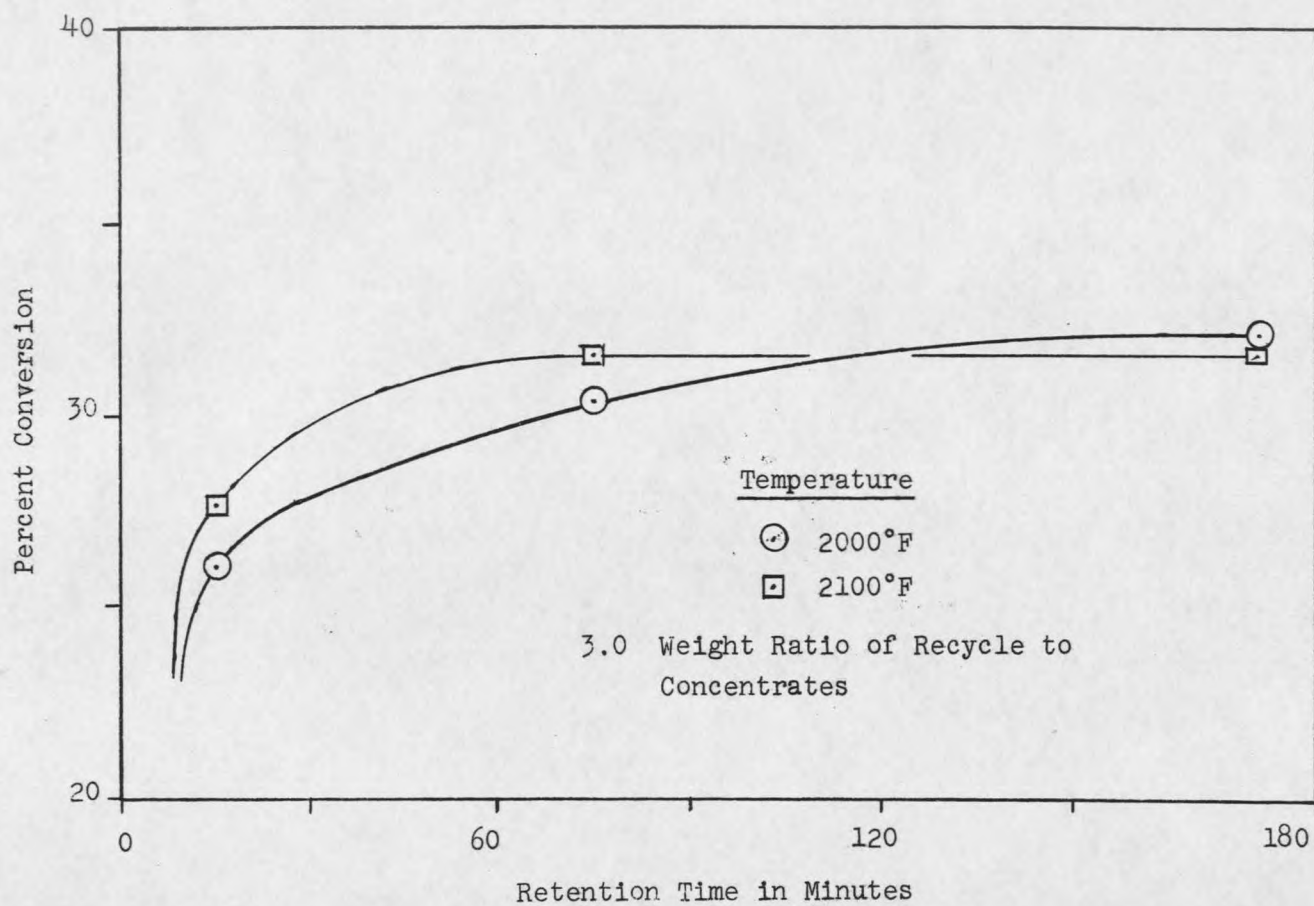

Figure 10. Plot of Percent Conversion vs. Retention Time for Muffle Samples Containing 17 Wt.% Na_2CO_3

ANALYTICAL PROCEDURES

Kiln Samples

Total chrome analysis was performed in duplicate for each kiln product sample. Each product sample was also analyzed in duplicate for soluble chrome content. The samples were split to obtain about 50 grams of material which was then powdered using a mortar and pestle and dried at 250°F.

Muffle Samples

As with the kiln samples, both total and soluble chrome analysis was performed in duplicate. The soluble chrome sample was obtained by scraping the surface of the muffle sample in order to obtain only the uppermost layers which were best exposed for oxidation.

Total Chrome Analysis

A sodium peroxide (Na_2O_2) fusion was employed for total chrome analysis. Approximately 5.0 grams of Na_2O_2 was added to 0.500 grams of sample in an Armco iron crucible. The bulk of the Na_2O_2 was thoroughly mixed with the sample and the remaining Na_2O_2 used to completely cover the top of the sample. The fusion was performed in an electric furnace at 750°F for two hours. The fused sample and crucible were then placed in 200 ml of water. The sample was dissolved and the crucible removed and washed free of adhering fusion product. The dissolved sample was then boiled fifteen minutes in order to destroy the excess Na_2O_2 . The solution was cooled to room temperature and then treated and titrated

in the same manner as the soluble chrome samples.

Soluble Chrome Analysis

A 2.500 gram sample was carefully weighed out and washed with 250 ml of hot water. The filtrate contained all of the soluble chrome as sodium chromate (Na_2CrO_4) as well as other dissolved salts.

Chemical Treatment of Dissolved Chromium Samples

1. Neutralize with 1:1 H_2SO_4 and dilute to 300 ml with distilled water.
2. Acidify with 60 ml of 1:1 H_2SO_4 and boil 15 minutes.
3. Add 10 ml of 2.5 percent AgNO_3 solution. Add 5.0 grams of $(\text{NH}_4)_2\text{S}_2\text{O}_8$ (ammonium persulfate). Add 4.0 ml of 0.1 normal KMnO_4 (potassium permanganate). Boil ten minutes.
4. Add 10 ml of 10 percent NaCl solution. Boil ten minutes.
5. Cool to room temperature and titrate.

Titration of Chromium Samples

1. Add 0.198 normal $\text{FeSO}_4 \cdot (\text{NH}_4)_2\text{SO}_4 \cdot 6\text{H}_2\text{O}$ (ferrous ammonium sulfate) until the yellow solution changes through olive green to grass green. Then add 5 ml in excess.
2. Allow the solution to stand at least five minutes, then add two or three ml of 85 percent phosphoric acid to sharpen the end point.
3. Back titrate with 0.198 normal KMnO_4 until a pink hue is observed. This is the end point.

The following calculation for percent Cr_2O_3 is based on a 0.500 gram sample and titration solutions of 0.198 normal concentration.

ml of 0.198 N. $\text{FeSO}_4 \cdot (\text{NH}_4)_2\text{SO}_4 \cdot 6\text{H}_2\text{O}$ minus ml of 0.198 N. KMnO_4
equals percent Cr_2O_3

The percent Cr_2O_3 must be divided by five for the 2.500 gram soluble chrome samples. If the titration solutions are not exactly 0.198 normal, then the milliliters of solution used must be adjusted to equivalents of 0.198 normal solutions before using the above expression.

Standard Solutions and Reagents

The potassium permanganate solution for titration was standardized with sodium oxalate ($\text{Na}_2\text{C}_2\text{O}_4$). Then the ferrous ammonium sulfate solution strength was determined by titration with the standardized potassium permanganate. The details of standardizing as well as reagent preparation may be found in Scott's STANDARD METHODS OF ANALYSIS, VOLUME I (3).



3 1762 10013832 8

N378

G666

cop.2

153037

Gore, R. L.

Air oxidation of chrome ore

NAME AND ADDRESS	
FEB 7 '63	Kujawa, Pat 209 So 5th
2-7-63	Lang, Wally 410 W. Harjeld
2-2-66	John Conrad 229 Eastern Blvd
2-24-66	Nguyen Det, H330
	MAP 8 1966
	Dayton Silva 226 Hedges
12-10-67	Dayton 226 Don

N378

G666

cop. 2

3-12

MAP ?

153037