

THE EFFECTS OF USING DICHOTOMOUS KEYS WITH ANALOGIES ON  
COLLEGE STUDENTS' UNDERSTANDING OF BIOLOGY CONCEPTS

by

Robin Francis Tillman

A professional paper submitted in partial fulfillment  
of the requirements for the degree

of

Master of Science

in

Science Education

MONTANA STATE UNIVERSITY

Bozeman, Montana

July 2011

STATEMENT OF PERMISSION TO USE

In presenting this professional paper in partial fulfillment of the requirements for a master's degree at Montana State University, I agree that the MSSE Program shall make it available to borrowers under rules of the program.

Robin Francis Tillman

July 2011

## ACKNOWLEDGMENTS AND DEDICATION

I gratefully acknowledge Montana State University and the College of the Rockies for their contributions to this project. Specifically, I thank Jewel Reuter, my capstone project advisor, whose criticism developed and focused my ideas; Elinor Pulcini, my science project reader; my colleague and mentor Doug McBride, who along with my department head Sharon Richardson, inspired me to pursue this master's program; the College of the Rockies Professional Development Committee for its generous financial support; and the students in the winter 2011 section of my Biology 090 course, whose participation and feedback provided me with the insights on which this project rests. Finally, I am grateful to the following individuals for their input and support as members of my validation team: Jack Loeppky, Doug McBride, Laura Cooper, and Kendra Eneroth.

I dedicate this paper to the memory of Frank Tillman, foremost among the inspiring teachers whom I have been fortunate to know and learn from.

## TABLE OF CONTENTS

INTRODUCTION AND BACKGROUND	1
CONCEPTUAL FRAMEWORK	4
METHODOLOGY .....	15
DATA AND ANALYSIS .....	29
INTERPRETATION AND CONCLUSION .....	52
VALUE .....	56
REFERENCES CITED.....	59
APPENDICES .....	62
APPENDIX A: Sample Approximate Analogies (Co-Intervention Strategy) .....	63
APPENDIX B: Sample Dichotomous Key (Main Intervention Strategy) .....	65
APPENDIX C: Project Definitions and Frames of Reference.....	67
APPENDIX D: The Original and Revised Taxonomy of Knowledge.....	73
APPENDIX E: Analogy Assessment Guide and Rubric .....	75
APPENDIX F: Teacher-Generated Dichotomous Key Rubric .....	77
APPENDIX G: Observer Comment Sheet (All Units) .....	79
APPENDIX H: Sample Nontreatment Lesson (Lecture and Lab) .....	84
APPENDIX I: A Traditional Dichotomous Key for Identifying Insects .....	90
APPENDIX J: Vocabulary Concept Lists .....	92
APPENDIX K: Comment Sheet for (Peer) Review of Dichotomous Keys.....	98
APPENDIX L: Student Attitude Scale (All Units) .....	100
APPENDIX M: Pre, Post, and Delayed Unit Assessment (Nontreatment) .....	105
APPENDIX N: Pre, Post, and Delayed Unit Assessment (Treatment 1).....	108
APPENDIX O: Pre, Post, and Delayed Unit Assessment (Treatment 2).....	112
APPENDIX P: Pre, Post, and Delayed Unit Assessment (Treatment 3) .....	115
APPENDIX Q: (Concept) Interview Questions (All Units) .....	118
APPENDIX R: Quantitative Scoring Rubrics for Concept-specific Questions..	124
APPENDIX S: Teacher Attitude Scale (All Units).....	126
APPENDIX T: Journal Prompts .....	129
APPENDIX U: Project Timeline .....	131
APPENDIX V: Preimplementation and Implementation Timeline Comparison	134
APPENDIX W: Assumptions and Limitations of Quantitative Analysis .....	136
APPENDIX X: Quantitative Data Analysis Plan .....	138
APPENDIX Y: Sample Calculations .....	141
APPENDIX Z: Comparison of Biology Students' Mean Scores between Units (Understanding and Long-Term Memory) .....	145

TABLE OF CONTENTS – CONTINUED

APPENDIX AA: Comparison of Biology Students' Mean Scores between Units (Lower- and Higher-Order Thinking Skills).....	149
APPENDIX AB: Student-Generated Dichotomous Keys.....	152
APPENDIX AC: Students' Posttreatment Comments about Dichotomous Keys .....	164

## LIST OF TABLES

1. Data Triangulation Matrix .....	24
2. Students' Mean Scores on Preunit and Postunit Assessments.....	30
3. Interviewed Students' Mean Scores on Preunit and Postunit Assessment Concept Interview Questions .....	31
4. Interviewed Students' Preunit and Postunit Assessment Mean Scores by Academic Level .....	31
5. Students' Mean Scores on Postunit and Delayed Unit Assessments.....	32
6. Interviewed Students' Postunit and Delayed Unit Assessment Mean Scores by Academic Level .....	33
7. Comparison of Students' Mean Scores within Each Unit .....	34
8. Comparison of Students' Mean Scores between Units (Understanding).....	35
9. Comparison of Interviewed Students' Mean Scores between Units by Achievement Category (Understanding).....	35
10. Comparison of Students' Mean Scores between Units (Long-Term Memory).....	35
11. Comparison of Interviewed Students' Mean Scores between Units by Achievement Category (Long-Term Memory).....	35
12. Effects on Students' Self-Perceived Understanding of Biology Concepts.....	36
13. Effects on Students' Self-Perceived Long-Term Memory of Biology Concepts .....	37
14. Students' Comments about Understanding and Long-Term Memory of Biology Concepts.....	37
15. Student-Generated Analogies for Biology Concepts .....	39
16. Comparison of Preunit and Postunit Assessment Mean Scores by Question Type.....	43
17. Interviewed Students' Mean Scores on Preunit and Postunit Assessment Concept Interview Questions by Cognitive Level .....	44
18. Comparison of Students' Mean Scores within Each Unit (Cognitive Level).....	45
19. Comparison of Students' Mean Scores between Units (Lower-Order Questions).....	45

## LIST OF TABLES – CONTINUED

20. Comparison of Students' Mean Scores between Units (Higher-Order Questions) .....	45
21. Effects on Biology Students' Self-Perceived Higher-Order Thinking Skills .....	47
22. Effects on Biology Students' Attitudes Toward Biology .....	48
23. Effects on Biology Students' Motivation to Learn Biology .....	49
24. Motivation of Biology Students as Evidenced by Number of Dichotomous Keys .....	50

LIST OF FIGURES

1. Comparison of effects on biology students' cognitive skills by mean percent difference .....46

## ABSTRACT

My introductory biology students are expected to acquire an extensive vocabulary and I have noticed that they often struggle to learn and make connections between the many Greek and Latin derived terms. This study investigated the effects of dichotomous keys with analogies on college students' understanding of concepts. Twenty adult students enrolled in one section of my Grade 12 equivalent biology course participated.

A combination of quantitative and qualitative data collection tools were used to evaluate my intervention's impacts on understanding, long-term memory, and higher-order thinking skills. Data from the three treatment units were compared to one nontreatment unit during which only existing teaching methods were employed. Paired two-tailed *t*-tests were used to quantify any differences observed between the preunit, postunit, and delayed unit assessment scores. Student-generated works, and interview data obtained from low-, middle-, and high-achieving students, were compared to allow for triangulation of the data.

Other forms of data collection were used to determine the effects of dichotomous keys with analogies on biology students' attitudes and motivation. Students' written comments on pretreatment and posttreatment attitude scales were compared to identify trends and outliers, while responses to Yes/No questions were quantified using chi-square analyses. In addition, teacher journaling and classroom observations by a peer observer were employed. The effects on my own teaching, time management, and attitude were assessed through the use of teacher attitude scales, journaling, and peer observations.

The data indicate no significant improvement in students' overall conceptual understanding and higher-order thinking skills following the treatment period, but significant benefits were observed with respect to concept retention. Both lower-order thinking skills, and student and teacher attitudes and motivation, yielded mixed results. One group of students thrived during the prolonged use of dichotomous keys, while the other group became frustrated with, and disengaged from, its highly structured format.

## INTRODUCTION AND BACKGROUND

My college-level biology students are asked to acquire an extensive vocabulary in a short period of time and many of them find this task challenging. I also expect students to progress beyond basic understanding by providing detailed explanations of relationships between terms. Factors contributing to my students' difficulties in mastering vocabulary include the large number of words derived from Latin and Greek, diverse student learning styles, and my choice of teaching and learning strategies. I have noticed that my control over the learning environment is a critical factor affecting my students' success. My goal was to identify the most effective learning environment possible, which prompted me to reflect on strategies I currently use and to then respond by deliberately modifying my teaching approach to improve student outcomes. The objective of my capstone project was to plan and implement a strategy specifically designed to help introductory biology students learn and make connections between concepts so that they enter their intended receiving programs with the knowledge and skills to succeed. I developed a focus question and four subquestions to guide me through the planning, implementation, and evaluation phases of my project.

The focus question for my project was, what are the effects of using dichotomous keys with analogies on college students' meaningful understanding of biology concepts? The project subquestions were as follows: what are the effects of using dichotomous keys with analogies on students' long-term memory of biology concepts; what are the effects of using dichotomous keys with analogies on biology students' higher-order thinking skills; what are the effects of using dichotomous keys with analogies on biology students'

attitudes and motivation; and what are the effects of using dichotomous keys with analogies on my teaching, time management, and attitude?

My project intervention was a hybrid strategy that combined the use of analogies with dichotomous identification keys (DI keys). An analogy is a comparison between a less familiar concept and a more familiar one, such as comparing a cell and its organelles to a city and its institutions. I have included some of my own examples of everyday and science-related analogies in Appendix A. With respect to my project, a DI key is a branching diagram that illustrates the relationship between three concepts at a time using connecting words and lines. Readily observable criteria are used to distinguish two terms from each other while simultaneously linking them to a more general concept in the hierarchy. A sample DI key I created on the theme of blood composition can be found in Appendix B.

The setting for my project was an introductory biology classroom with 20 students at the College of the Rockies (COTR) in Cranbrook, Canada. Situated 60 miles north of the 49<sup>th</sup> parallel, Cranbrook is a rural city of 19,000 located in the Rocky Mountain Trench in the southeast corner of British Columbia. Spokane, Washington; Coeur d'Alene, Idaho; and Kalispell, Montana are popular U.S. destinations for area residents.

The COTR is a publicly funded community college and represents the only postsecondary option physically located in the region. With five satellite campuses, it serves an East Kootenay population of 84,000. Although originally established as East

Kootenay Community College in 1975, the current Main Campus building opened in 1982. COTR has a full-time equivalent student population of 2,500 (2009-2010 data).

I have 16 years of teaching experience including four years as a COTR biology instructor. By acquiring their Grade 12 biology equivalency with me, students have a self-directed opportunity to reassess their interest and aptitude in this field before pursuing a biology-related career. Most are recent local high school graduates interested in health-care related programs like nursing. I also deliver several first-year biology labs, but because they are taught in cooperation with a number of other instructors, I excluded these courses from my project. My project's personal significance was rooted not only in its potential use as a learning strategy in my other biology courses, but also in its possible applications as a vocabulary learning tool in other high school and college-level courses in general.

The team I assembled to advise and support me throughout this study was led by my capstone project advisor, Jewel Reuter, Ph.D., an instructor in the Master of Science in Science Education (MSSE) program at Montana State University (MSU). My science project reader was Elinor Pulcini, Ph.D., a research scientist at the MSU Center for Biofilm Engineering. My validation team members included Doug McBride, Ph.D., a biology instructor and researcher at the COTR, and Jack Loeppky, Ph.D., a retired respiratory physiologist formerly of the University of Albuquerque in New Mexico. In addition, Laura Cooper, Ph.D., an ethnographer and Dean of Instruction at the COTR, served as my humanities expert and classroom observer, while Kendra Eneroth, a fellow

student in the MSSE program and high school science teacher in Spokane, Washington, provided me with peer feedback.

## CONCEPTUAL FRAMEWORK

In this conceptual framework, I will identify and summarize the general themes and patterns in the literature that have led me to consider and implement DI keys with analogies as a learning strategy in my biology classroom. Constructivism and metacognition theory will serve as the main concepts linking education research to my classroom practice. The instructional concerns I have identified as my priorities are to develop students' meaningful understanding of the biology concepts, improve their long-term memory and higher-order thinking skills, positively impact attitudes and motivation, and alleviate time constraints. I have included information on several other subthemes relevant to my choice of intervention strategies in Appendix C. I will conclude by reviewing some of the most recently published applications of analogies and DI keys by high school and college biology teachers in European, Australian, and North American classrooms.

To help college curriculum builders and instructors define learning objectives, plan learning experiences, and assess students, Bloom (1956) identifies six major classes of knowledge, or cognition. I have included the six levels of knowledge as defined by Bloom in Appendix D along with its recent revision by Anderson and Krathwohl (2001), an update which reflects the important role of metacognition in learning. A thorough background in knowledge and metacognition theory enabled me to develop the tools I

used to assess changes in my students' understanding, long-term memory, and higher-order thinking skills during project implementation. Additional information on the original and revised taxonomy can be found in Appendix C.

Flavell (1979) builds on Bloom's foundation by describing how knowledge itself is generated through the process of metacognition, sometimes also referred to as cognitive monitoring or more simply as thinking about thinking. The theory of metacognition assumes that students possess prior knowledge and beliefs about how they learn best. If instructors encourage students to challenge their prior knowledge, they will be forced to resolve the conflict between their existing knowledge and what they are currently learning, a prerequisite to constructing new knowledge. According to Flavell, a teacher's use of metacognitive strategies makes students' thinking visible so that teachers can monitor changes in conceptual understanding over time. To monitor my own students' thinking, I can choose and/or devise learning strategies that require their active participation in my lessons. Numerous studies have identified both concept maps (Kinchin, 2000, 2001; Mintzes, Wandersee, & Novak, 2001; Novak, 2004; Novak & Cañas, 2008) and analogies (Middleton, 1991; Venville & Treagust, 1997; Orgill & Bodner, 2007) as learning tools that engage biology students' prior knowledge.

According to Bransford, Brown, and Cocking (2000), the rapid increase in factual knowledge now "renders its coverage by education an impossibility" (p.5). Educators should respond by shifting the learning focus from acquiring factual knowledge to developing the skill set to access it (Bransford et al., 2000; Lauer, 2005). Gardner (2008a) endorses this shift away from teaching factual knowledge toward what he

describes as developing a disciplined mind. In contrast to the memorization of facts and figures that characterizes a subject matter focus, learning a discipline “constitutes a distinctive way of thinking about the world” (p.27). According to Gardner, science courses ought to develop students’ abilities to think as a scientist and, in so doing, better prepare them for the world of the future. He recommends that educators set up “performances of understanding” under a variety of conditions to determine the extent to which students are learning to think scientifically (p.34).

Both factual recall and understanding are considered lower-order thinking skills (see Appendix D). Therefore, expecting my students to merely acquire an understanding of the biology concepts is inadequate considering one of my main instructional goals is to help them develop their higher-order thinking skills through mastery of the course content. I have included a definition of *meaningful understanding* as described in both the original and revised taxonomy of knowledge in Appendix C.

Using a control group and an instructed group to compare changes in students’ conceptual understanding, Novak (2004) describes the results of a 12-year longitudinal study on primary children in which only the students instructed in concept mapping showed continuing improvement in their understanding of basic science concepts. His work demonstrates the advantage of learning science concepts meaningfully by making connections between a hierarchy of vocabulary words and propositions, in other words, by engaging students’ higher-order thinking skills using concept mapping activities. Results from a Brazilian case study of ninth-grade science students also support the claim

that a constructivist approach produces more meaningful learning (Jofili, Geraldo, & Watts, 1999).

More complex learning tasks involve accessing knowledge using not only lower-order, but also higher-order, thinking skills. I have included a definition of *higher-order thinking skills* (Bloom, 1956; Anderson & Krathwohl, 2001) in Appendix C. Given the demand for active participation required by complex learning tasks, I should provide my students with a learning environment in which their input is not only appreciated, but essential to constructing new knowledge, a reflexive process that values both external feedback and critical self-evaluation. My intervention strategy should also challenge students to compare what is stored in their long-term memory (ie. prior knowledge) to the concepts currently occupying their short-term attention. Novak (2004) has demonstrated concept mapping as a learning tool that helps science students retrieve prior knowledge from their long-term memory.

According to Rose, Myerson, Roediger, and Hale (2010), recall of a minimum number of concepts is required to activate students' long-term memory. Rose et al. test the hypothesis that retrieval from long-term memory is involved when carrying out a learning task. In a study of college undergraduates involving both immediate and delayed testing, they found that long-term memory improves when students are given retrieval practice with eight-item, but not four-item, word lists. The authors account for this difference by explaining that simple tasks, with approximately four words or "chunks" of information, activate only short-term memory, whereas complex tasks involving more than four words require students to access both short- and long-term

memory (p.472). According to Rose et al., providing retrieval practice activities benefits students' long-term concept retention if they are required to process a greater number of concepts in the allotted amount of time. Appendix C contains definitions, as well as a graphic I developed, to summarize the relationship between *short-term memory*, *working memory*, and *long-term memory* as most widely recognized by psychologists. This research informs me that I should design my instructional tasks around a minimum of eight vocabulary words to activate students' long-term memory as they make decisions about the relationships between concepts in their DI keys. Still other neuroscience research suggests that teachers ought to provide a multisensory learning approach to develop their students' understanding, higher-order thinking skills, and long-term memory. I have included information about the implications of recent brain research on student learning in Appendix C.

By encouraging my students to use their interpersonal and visual-spatial abilities when creating DI keys, I hope to help them acquire knowledge and skills that can more readily be accessed from their long-term memory. I have included Gardner's (2008b) eight intelligences and his explanation of the difference between learning styles and intelligences in Appendix C. It would be prudent for me to design my DI keys to target as many of the intelligences as possible and as often as possible. While Kinchin (2000) is a strong advocate for the use of concept mapping in biology, he cautions that "like all teaching tools, concept mapping is not a panacea; it will not suit all learners or all learning activities" (p.67). This cautionary message highlights the importance of

integrating my DI keys with existing learning strategies that I have already found are effective with my introductory biology students.

Another area of current educational research includes the development of instructional methods that increase active student participation in the learning process as alternatives to a more passive, or traditional, teacher-driven model. According to Jofili, Geraldo, and Watts (1999), constructivism is an instructional approach that “presupposes that knowledge is actively constructed by learners through interaction with physical phenomena and interpersonal exchanges” (p.6). Osborne and Freyberg (1985) describe the advantages of a constructivist model in science that they term “generative” (p.108). Its three steps are: focus (including motivation), challenge (exploring alternatives), and application (problem solving with respect to the “accepted scientific viewpoint”) (p.110). According to Lauer (2005), a constructivist approach can successfully be used to teach college biology content in a lecture format. Through his own use of constructivist strategies in an introductory biology course, Lauer reports that students considered the improvement in their critical thinking skills to be as important as their increased content knowledge. By using DI keys to increase the level of active participation in my lessons, I hope to positively influence my students’ critical thinking skills and attitudes toward biology, and consequently their determination to succeed in the course.

In addition to developing and assessing students’ conceptual understanding and thinking skills in the cognitive domain, a course curriculum may also refer to developing students’ attitudes, which addresses the so-called affective domain of feelings or emotions elicited by a course. To create an analogy of my own, attitude is to the cause as

motivation is to the resulting behavior or effect. I have included my definitions for *attitude* (Bloom, 1964; Koballa & Crawley, 1985, as cited in Rogers & Ford, 1997) and *motivation* (Allan, 1990) in Appendix C. In their comparative study of undergraduate students in biology courses for majors and nonmajors, Rogers and Ford (1997) use data obtained from an attitude scale to conclude that instructors should not assume their students will necessarily acquire positive attitudes toward biology just because they are biology majors instead of nonmajors. In their study involving an upper-level college biology course, Kitchen, Reeve, Bell, Sudweeks, and Bradshaw (2007) found that students displayed significant increases in their attitudes when the course emphasized higher-order thinking skills over information acquisition and recall.

Shavelson, Young, Ayala, Brandon, Furtak, and Ruiz-Primo (2008) studied the effects of aligning assessments with constructivist goals on middle-school science students' motivation, achievement, and conceptual change. In their small randomized field study, Shavelson et al. embedded formative assessments in the science curriculum and trained teachers in their use before these teachers implemented the unit of study in their respective classrooms. Concept maps were among the formative assessment strategies used. The authors found a "large variability in teachers' practices, regardless of treatment condition, which in turn impacted student outcomes" (p.310). Given that I am both the curriculum and assessment developer in my teaching environment, Shavelson et al. demonstrate the need for me to plan the most effective use of DI keys if I am to expect my students to accept and benefit from this constructivist learning tool. On the other hand, my project's outcome may not only depend on internal factors like my

students', or my own, attitudes and motivation. Therefore, I have included information on the impact of instructional time and teacher effectiveness in Appendix C in acknowledgment of the external factors that influence my biology classroom.

The intervention strategy I develop or select should help me and my students plan and prioritize our learning. Furthermore, the goals of the DI keys I assign should be clearly defined and communicated so that my purpose in teaching and students' learning outcomes overlap as much as possible. Determining both how well I am managing class time and to what extent class activities are achieving their intended outcomes can be assessed regularly using a variety of classroom assessment techniques.

An essential stage in the learning cycle involves a teacher's determination of how well students have mastered specific learning outcomes. Classroom assessment has two main purposes: "to improve student learning (formative assessment) and to assign grades to students that reflect degrees of learning (summative assessment)" (Anderson & Krathwohl, 2001, p.233). According to Bransford et al. (2000), use of simple formative assessments to provide frequent feedback promotes "learning for understanding" (p.140). In addition, students should be given opportunities to reflect on their ideas and those of others. This can be accomplished through frequent use of classroom assessment techniques (CATs). Two examples of CATs for monitoring students' progress are approximate analogies and concept maps (Angelo & Cross, 1993).

Identifying the similarities and differences between two concepts is one strategy designed to help students connect new ideas to their existing knowledge. Orgill and Bodner (2007) describe "comparisons between two domains – a familiar domain often

known as the analog – and a less familiar domain known as the target” (p.244). Angelo and Cross (1993) define an approximate analogy as completion of the statement “A is to B as X is to Y”, essentially a scientific simile (p.193) (see Appendix A). Analogies promote active learning and critical thinking with secondary benefits to students’ creativity and enjoyment of learning. According to Middleton (1991), student-generated analogies are less likely to create confusion than teacher-generated comparisons. Orgill and Bodner report analogy use by students as a “stepping-stone” to visualizing a new concept before replacement of the analog with the target (p.246). Accordingly, teachers should make an analogy’s purpose clear so that their students use the comparison for the intended purpose instead of as a replacement for the actual target concept (Orgill & Bodner, 2007; Venville & Treagust, 1997). Venville and Treagust have developed a three-step FAR (Focus, Action, and Reflection) Guide that students can use to assess the inherent limitations of a specific analogy. Their FAR Guide and the rubric I developed to assess my students’ biology analogies can be found in Appendix E. I will expect my students to include one analogy in their DI keys to demonstrate that they have made a relevant connection between a biology concept and another idea from their everyday lives. Next, because DI keys are concept maps, I will briefly rationalize and summarize their use in biology education as described by the recognized leaders in this field.

Using concept maps to graphically organize vocabulary words is another strategy students can use to connect new ideas to their prior knowledge. A concept map is a visual summary of vocabulary relationships. Mintzes, Wandersee, and Novak (2001) review techniques for assessing biology students’ understanding, including use of

concept maps as “a powerful tool in depicting cognitive deficiencies” (p.119). According to the authors, individual and group-generated maps are effective in monitoring concept development over time. Kinchin (2001) describes significant problems with their use in summative assessment if the intent is to quantitatively score them against an expert map or teacher-generated rubric. Concept maps are considered especially useful as graphic organizers for visual learners (Kinchin, 2000). Novak and Cañas (2008) recommend that teachers have their students draft a preliminary map as an answer to a specific focus question instead of merely being assigned a one- or two-word topic. Students can then be provided with a parking lot of 15 to 25 words to work with, which is a “list of concepts that the teacher wants to make sure all students include in their map” (p.18). Next, students should rank order the list by placing the most general concept at the top and progressively working down to the most specific concepts at the bottom. According to Novak and Cañas, although never truly finished, three or more revisions usually produce a good concept map. Although they share some common features, DI keys differ from other concept maps in a number of significant ways.

DI keys are essentially traditional, or hierarchical, concept maps if represented graphically instead of using alternate paired statements. Allan (1990) defines ‘dichotomy’ as “a division into two, especially a sharply defined one” (p.323). Bavis, Seveyka, and Shigeoka (2000) describe the use of DI keys in biology education often with analogies and simple sketches. An introductory activity is recommended involving the sorting of household items into groups (Gobalet, 2003; Šorgo, 2006; Watson & Miller, 2009). New objects are provided after initial sorting so that students can test their

classification's effectiveness. After discussion, DI keys are introduced as a distinct identification tool. Pairs of students create DI keys using the most clearly visible distinguishing characteristic if more than one observable feature will divide the category. Students are reassured that there are multiple right answers and that a DI key can be difficult to construct. Sources suggest using between 15 and 20 concepts (Kinchin, 2000; Watson & Miller, 2009). Šorgo (2006) recommends that teachers limit DI keys to one or two branching levels in early lessons and then build in complexity over time. DI keys must include only one pair of lines or arrows per division and a statement identifying the branching criterion. Watson and Miller employ traditional paired-statements while Šorgo uses a modified concept map with lines connecting a word or statement (also see Kinchin, 2000). Partners construct and test their own DI keys before providing feedback to other groups. Šorgo claims that "because they were forced to divide into two subgroups each step, students were able to recognize the method as more complex compared to the construction of basic concept maps" (p.19).

The literature describes how to construct and use DI keys, but studies lack a detailed analysis to verify claims of laddering students to higher-order understanding (Bavis et al., 2000; Gobalet, 2003; Šorgo, 2006; Watson & Miller, 2009). While research on concept mapping is consistently positive (Kinchin, 2001), absence of data specific to DI keys presents an opportunity for further study. By implementing DI keys with analogies as a formative assessment technique throughout instruction, I intend to create a highly effective and enjoyable learning environment in which students reconsider prior knowledge, actively learn and link vocabulary using multiple learning styles, and retain

concepts over the long-term. Inclusion of a comprehensive data collection and analysis plan will be critical in providing me with the information I need to determine if DI keys with analogies significantly improve student outcomes.

My synthesis of the literature suggests that students may be better able to master biology concepts across the knowledge levels if I create a more constructivist learning environment as follows: provide opportunities for my students to think about their thinking by challenging prior knowledge; make learning of vocabulary a visual and social experience that engages a variety of my students' learning styles; provide students with frequent feedback to closely monitor the accuracy of their newly constructed knowledge; encourage my students to compare new concepts to familiar ones; and challenge students to represent their understanding of concepts by creating and evaluating their own graphic organizers with my input and guidance. Shifting my overall teaching focus to a disciplined and theme-based approach from a quantity-driven model may also positively influence students' attitudes about biology class while alleviating my preoccupation with time as the dominant factor affecting my choice of learning strategies. Implementation of DI keys with analogies was one means I hoped would achieve this learning environment.

## METHODOLOGY

### Project Treatment

My project implementation occurred in the first 10 weeks of the winter semester in 2011 during which four units of study were covered. One nontreatment unit using

current teaching and learning methods was followed by three treatment units each with the intervention applied so I could compare its effectiveness to that of the nontreatment learning environment.

I implemented DI keys with analogies as the intervention in my introductory biology class. My objective was to improve students' vocabulary acquisition and long-term concept retention through frequent use of student-generated graphic organizers and comparisons. Students were assigned the daily and weekly task of creating DI keys with routine use of analogies, examples, sketches, page references, and word derivations. Use of a teacher-generated formative assessment rubric to evaluate their own and others' DI keys was an integral part of my students' learning experience. A copy of this rubric can be found in Appendix F.

The nontreatment unit was an introductory unit covering the characteristics of life, taxonomy, and biological molecules. A typical lecture began with a brief chalkboard review of previously covered vocabulary concepts and involved identification of the appropriate term by a volunteer or student selected by me. A teacher-directed discussion followed combining simultaneous (or real-time) note-taking on a chalkboard with the viewing of narrated online tutorials and overhead transparencies (lecture with observer). A third-party observer kept handwritten notes using both unstructured comments and prompts I had developed to provide feedback on my teaching and students' responses before and during implementation of DI keys. The observer I selected is an expert in the field of ethnographic research with a doctorate degree in education, specifically in experimental methodologies in medical anthropology. Dr. Laura Cooper observed two

lessons during each of the four units of study including one lecture and one lab. A copy of the comment sheet that I developed for her use can be found in Appendix G.

A nontreatment lab period also began with a chalkboard review of the week's concepts. Student pairs then followed step-by-step lab-guide procedures as they used molecular model kits to build biological molecules and made written and diagram observations of cells (lab with observer). I checked off various lab procedures on students' lab guides for accurate completion and collected lab activities the following week to assign marks for prespecified tasks. I have included a copy of a typical nontreatment unit lecture and lab lesson in Appendix H. No formal lab write-ups were required during the nontreatment unit as was the norm during both the first two weeks of classes and the rest of my project implementation period. I continued with my nontreatment teaching approach and learning strategies during the 3<sup>rd</sup> and 4<sup>th</sup> lessons, which formally ended the nontreatment unit.

In order to simplify the treatment description that follows, the two weekly lectures and single lab period are considered two weekly lessons in my study. In addition, no distinction has been drawn between lecture and lab lessons for the purpose of this project in that my intervention strategy was applied equally across both lesson formats. I inserted concept development activities at the start of each lesson during the third week (as a one-week interlude) to introduce students to my two intervention concepts. The first of these activities occurred in the 5<sup>th</sup> lesson when I asked students, what is an analogy? A definition was generated from student input and several examples from everyday life and science were recorded on the board. I then introduced the concept of

an approximate analogy (Angelo & Cross, 1993) and provided several examples of my own creation before asking student pairs to create one approximate analogy of their own (see Appendix A). The instructions for this task were to make an original comparison between a biology concept of their choice and an everyday concept using the format “A is to B as X is to Y”. Potential problems of making an analogy were outlined before students were provided with, and shown how to use, a simple tool to assess the limitations of their comparisons (Venville & Treagust, 1997) (see Appendix E).

With the concept of analogies addressed, I introduced students to my main intervention strategy by asking them, what kinds of things do people classify, and why? After brainstorming a list on the chalkboard from students’ ideas, student pairs completed an introductory activity involving the grouping of 18 household items into categories based on their similarities and differences. The instructions for this task were to sort the hardware items provided into six to ten categories based on the physical characteristics that students decided were most important. Each group was then provided with two new items after the initial sorting process so that students could test the effectiveness of their classification scheme. Finally, students were required to briefly justify their grouping strategy aloud to the class by self-identifying its strengths and weaknesses before receiving verbal feedback from fellow students and me on their system’s advantages and limitations.

In the 6<sup>th</sup> lesson, I introduced students to the DI key as a distinct classification tool by defining dichotomy and providing examples of its traditional uses in botany and zoology. I showed students how paired alternate statements are routinely used to identify

tree and insect species. A copy of the traditional dichotomous key for insects that I provided to my students is found in Appendix I. Students now had a basic understanding of both intervention concepts. Completion of the 5<sup>th</sup> and 6<sup>th</sup> lessons during third week concluded the weeklong interlude between my nontreatment, and first treatment, unit. Because DI keys were implemented as a formative assessment tool to monitor learning in progress, I continued to base my summative evaluation (ie. students' formal grades) on the existing course worksheets, lab assignments, quizzes, and midterm exam used during the preimplementation period. My rationale in focusing my intervention on the improvement of formative assessment can be summed up with the following analogy: a DI key is to the development of conceptual knowledge as batting practice is to a baseball player preparing for the World Series.

The first treatment unit covered cell structure and function, specifically cells and organelles, the plasma membrane, and cell transport mechanisms. Given the additional class time I anticipated I would need to teach using a constructivist model, I provided my students with both online access to, and photocopied hand-outs of, my lecture notes, using direct teaching only to explain the more difficult concepts. In the 7<sup>th</sup> lesson, I instructed students on the basic rules of constructing DI keys and explained a four-point holistic rubric I developed to assess them, which involved ranking works from 4 (exceeds or fully meets all specified criteria) to 0 (not handed in or does not meet minimal expectations) (see Appendix F). My students were provided with both a paper hardcopy and an emailed softcopy for future reference and use. A teacher-guided activity followed with the class developing a DI key using footwear as a theme students could easily relate

to (D. L. Keanini, personal communication, September 17, 2010). This activity consisted of me asking each student to place his or her right shoe on the front lab bench. Next, whole-class discussion input was used to repeatedly divide the available footwear into two groups until each shoe had been identified by its unique physical characteristics. Student volunteers helped arrange the shoes while I modeled the branching process for DI keys on the chalkboard. Students were then assigned a practice activity to complete with a partner of their choice involving construction of their first course-specific DI key on cells and organelles (lecture with observer). The focus question for this task was, how can cells be categorized and which structural and functional units are they composed of? In order to provide greater initial guidance during the first two treatment units, my students were provided with a list of required words to include in their DI keys. A copy of the vocabulary lists I provided to my students for these initial DI key activities can be found in Appendix J. One week was the usual timeframe provided to draft, revise, and complete each assigned task.

In the 8<sup>th</sup> lesson, student pairs were instructed to return their rough draft to class on standard white photocopy paper for critiquing by two other groups and me (lab with observer). Peer reviewers and I recorded brief comments on paper half-sheets accompanying each draft. I have included a copy of the comment sheets used to critique DI keys in Appendix K. Next, individual students were assigned the task of creating a DI key on the theme of membrane transport mechanisms. The focus question was, what is the structure of the plasma membrane and which processes control what enters and exits the cell? Rough drafts were evaluated by two peers and me during the 9<sup>th</sup> lesson with

both the rough draft and final draft being submitted for hand-in on the due date. All DI keys were collected and stored in individual folders as evidence of change in my students' vocabulary understanding as a group. Students retained access to their folders and were encouraged to temporarily borrow them for personal study purposes. The 10<sup>th</sup> lesson formally ended the first treatment unit with students self-assessing their first two DI keys for possible improvements and incorporating my feedback.

The second treatment unit covered cell processes, specifically cell division and enzyme action. In the 11<sup>th</sup> and 12<sup>th</sup> lessons, student pairs were assigned the task of creating a single DI key, although each student was expected to submit his or her own copy. First, a DI key on the cell cycle was developed on the board using whole-class discussion input to practice the prerequisite skills as a group. The focus question for this task was, by which processes are cell numbers regulated, and for what purposes? Students were then given the individual task of creating a DI key on the theme of catalysts. The focus question was, what is the structure and function of enzymes, and which factors affect their ability to catalyze chemical reactions? I provided students with class time to begin and work on their DI keys with homework completion as the stated expectation (lecture with observer). During the 13<sup>th</sup> lesson, students reviewed the first six weeks of course content in preparation for their first summative evaluation. I created mixed-ability groups of three or four students in advance for this activity. Each group was responsible for organizing larger DI keys on chart paper to represent each of the six chapters covered to date, a unique activity in that only one lesson was provided to both start and finish this task (lab with observer). Although DI keys were used to review for

the first midterm exam, I did not use these data in my project because they included teaching methods and biology concepts from the nontreatment unit. Students wrote their first midterm exam in the 14<sup>th</sup> lesson, which was followed by a weeklong scheduled reading break without classes. This break formally ended my second treatment unit.

The third treatment unit covered metabolism and homeostasis. For the reading break, I assigned students the individual task of drafting a DI key on cellular respiration and photosynthesis to bring to class upon their return. The focus question was, how do cellular respiration and photosynthesis compare as metabolic processes? This assignment involved reading ahead in the required course textbook. From this point forward, one guideline for constructing DI keys was modified to reflect my increased expectations of students compared to the first two treatment units. Students were provided with only the focus question and were now responsible for identifying their own list of relevant concepts to include. That is, a parking lot of required vocabulary words was no longer supplied by me. My rationale in having students select their own vocabulary for these later DI keys was that I had provided enough guidance and practice in previous weeks to sufficiently prepare them to make these decisions themselves.

In the 15<sup>th</sup> and 16<sup>th</sup> lessons (lecture and lab with observer), rough drafts were circulated for both peer and teacher review before final drafts were handed in for teacher assessment, respectively. The 17<sup>th</sup> and 18<sup>th</sup> lessons included the drafting, critiquing, and revising of an individually assigned DI key on feedback mechanisms, the unifying concept linking all previously covered material to a sequential study of the human body systems. The focus question was, how do the two types of feedback mechanisms affect

the body's ability to maintain a constant internal environment? This task both ended the third treatment unit and my project implementation, after which I discontinued using DI keys with analogies pending my analysis and interpretation of the collected data.

### Data Collection Instruments

I chose my introductory biology class of 20 students for my capstone project because I teach this course every semester and, given my investment of time and effort, I have the desire to improve students' learning experiences where I can most make a difference. In addition, these students are generally well motivated given the large number of applicants competing for relatively few spaces in the locally offered receiving programs. These include the home care assistant, licensed practical nursing, and Bachelor of Science in nursing programs. Several students are also typically interested in out-of-area offerings such as the ultrasound or radiology technician programs. The majority of my students were local recent high school graduates, but several were resuming their education after a decade or more out of school. Seventy percent ( $n = 14$ ) were women and most were enrolled in other courses as part- or fulltime college students. Most of my students came from working class families and none of them were identifiable as visible minorities. Two students were also mothers.

The course consists of six instructional hours per week divided into two 90-minute lectures and one 3-hour lab period scheduled on separate days. There is typically a demand for one lecture and lab section in the fall term and one lecture and two lab sections in the winter. No cap is placed on enrolment in the lecture although student

numbers usually vary between 14 and 35 students (2007-2011 data). The COTR does not have a fixed policy for determining minimum enrolment, but having too few students to offer one section of the course has not been a factor during my tenure given that my biology course is a prerequisite for most of the health-related programs offered at the college. The maximum number of students per lab section is set at 18 and these two lab sections were scheduled on consecutive days during my project implementation period. All students take the lecture and lab components with me during the same semester. Because several online students also occasionally attend lessons, I limited my data collection to 20 of the 25 students who were officially registered in the face-to-face class and who had provided their written consent to participate in my study. The research methodology for this project received an exemption by Montana State University's Institutional Review Board and the College of the Rockies' Committee for Ethics in Scholastic Activities, and compliance for working with human subjects was maintained.

I collected both qualitative and quantitative data for each of my project questions to allow for triangulation. Table 1 shows the triangulation matrix I developed to organize the various data collection instruments used in comparing my nontreatment, to the three treatment, units.

Table 1  
*Data Triangulation Matrix*

Project Questions	Data Source		
	1	2	3
Focus Question: What are the effects of using dichotomous keys with analogies on	Preunit and postunit assessments	Preunit and postunit concept interviews	Teacher journaling, survey questions isolating understanding, and

college students' meaningful understanding of biology concepts?				artifacts in student folders
Subquestions: What are the effects of using dichotomous keys with analogies on students' long-term memory of biology concepts?	Postunit and delayed unit assessments isolating long-term memory	Postunit and delayed unit concept interviews isolating long-term memory		Teacher journaling and survey questions isolating long-term memory
What are the effects of using dichotomous keys with analogies on biology students' higher-order thinking skills?	Preunit and postunit assessments isolating higher-order thinking skills	Preunit and postunit concept interviews isolating higher-order thinking skills		Teacher journaling and survey questions isolating higher-order thinking skills
What are the effects of using dichotomous keys with analogies on biology students' attitudes and motivation?	Pretreatment and posttreatment attitude surveys	Nontreatment and treatment unit observations		Pretreatment and posttreatment individual interviews isolating attitudes and motivation
What are the effects of using dichotomous keys with analogies on my teaching, time management, and attitude?	Preimplementation and implementation timeline comparison	Nontreatment and treatment unit attitude surveys		Instructional observations and teacher journaling

My rationale for incorporating multiple forms of qualitative and quantitative data was to help me identify recurrent patterns and to increase my ability to measure the implemented strategy's effects on my teaching and students' learning. A pen-and-paper

pretreatment attitude survey and postunit assessment were administered to students at the end of the nontreatment unit to gather baseline data. I have included these pretreatment data collection instruments as Appendix items L and M, respectively. A posttreatment attitude survey was also completed by students at the end of the treatment period (also see Appendix L). I aligned questions developed for my preunit and postunit assessments with the revised taxonomy of knowledge (Anderson & Kratwohl, 2001) and administered them at the start and end of each two-week period to compare changes in students' vocabulary understanding. These preunit and postunit assessments for my three treatment units are included as Appendix items N through P. Long-term concept retention, and higher-order thinking skills, were individually assessed by completion of delayed unit, and postunit, assessments two weeks after, and at the end of, each unit, respectively (also see Appendix items M through P). With respect to the student interviews and student surveys, my concept-specific questions were asked each time these data collection instruments were administered. In comparison, I only asked my nonconcept (general) questions before and after the project treatment as a whole to minimize the risk of subject fatigue or boredom due to repetition.

I also had a colleague observe a typical nontreatment lecture and lab period during first week and a typical lecture and lab during each treatment unit to compare students' attitudes and motivation to learn before and during my implementation of DI keys. She recorded handwritten notes using both prompts and unstructured comments (see Appendix G). In addition, preunit, postunit, and delayed unit treatment concept interviews were conducted to monitor changes in individual students' conceptual

understanding, long-term memory, and higher-order thinking skills over time. My one-on-one interviews were administered to these six students outside of class time with two students each selected from the low-, middle-, and high-achieving categories based on their self-disclosed letter grades in their most recent biology course (or general science course if a student had never taken biology). These semistructured interviews were recorded as field notes before being transcribed, saved to a word processing document, and printed in hardcopy. The concept interview questions I used to assess my students are included in Appendix Q. I have also included copies of the vocabulary lists given to my interviewed students to complete the concept mapping question (see Appendix J).

With the exception of my multiple-choice questions and a concept mapping task, all of the concept-specific questions for the unit assessments, student surveys, and student interviews were scored using a four-point holistic quantitative rubric of my own design. The concept mapping task administered during my student interviews was scored using a separate holistic, quantitative rubric adapted from Mason (1992, as cited in Doran, Chan, Tamir, & Lenhardt, 2002) and Novak and Gowin (1984, as cited in Doran, Chan, Tamir, & Lenhardt, 2002). A copy of these rubrics is included in Appendix R.

The effects of a new teaching approach on my own teaching, attitudes, and time management were considered an important aspect in the implementation of my project treatment. Thus, I completed posttreatment attitude scales at the end of each unit to document my own perceptions throughout my study. A copy of the teacher attitude scale I developed for use with all of my units can be found in Appendix S. I also kept a daily research journal (with all pages dated) using both prompts and unstructured comments to

record my classroom observations and personal reflections, as well as to compare the implementation and preimplementation course timelines with respect to the number of instructional hours required to cover the same course content. My journal prompts and project timeline are included as Appendix items T and U, respectively. A comparison between my preimplementation and implementation timeline can be found in Appendix V.

Before gathering and analyzing quantitative data, I considered it essential to choose statistical tests appropriate to the sample sizes and distributions I was comparing in order to increase the validity of my results. Both the student and teacher attitude scale and my observer's comment sheet included Yes/No questions to make them amenable to chi-square analysis. In addition, I chose paired two-tailed *t*-tests to analyze my unit assessments because this calculation does not assume that the variances of the two populations are homogeneous. Thus, I compared data from the preunit, postunit, and delayed unit assessment scores ( $k = 2$ ,  $\alpha = 0.05$ ) with results being presented both in text ( $t$  at  $\alpha = 0.05$ ,  $p < 0.05$ ) and graphically using tables or figures. I analyzed the quantitative data by making comparisons from general to specific based on my scoring of students' responses to the concept-specific questions.

First, I drew a general comparison between my three treatment units (Unit 2, 3, and 4) and single nontreatment unit (Unit 1) to assess my intervention's overall effects on students' performance. This consisted of initially averaging the postunit minus preunit assessment differences (denoted *D*) for my treatment units (*D*<sub>2</sub>, *D*<sub>3</sub>, and *D*<sub>4</sub>) and then testing the null hypothesis that *D* is equal to *D*<sub>1</sub>. Secondly, I compared my students'

average scores as a group on the assessments within each unit as follows: postunit minus preunit assessment difference to assess change in conceptual understanding; and both delayed unit minus postunit, and postunit minus preunit assessment difference, to assess effects on students' long-term memory and higher-order thinking skills, respectively. These comparisons tested the hypotheses that D2, D3, and D4 are each greater than D1 because of my students' repetitive use of all treatment learning strategies combined. Thirdly, I compared the differences in students' average scores as a group on the assessments between each of the units in all combinations as follows: D4 to D3; D3 to D2; D2 to D1; D4 to D2; D4 to D1; and D3 to D1. These comparisons tested the various null hypotheses that the postunit minus preunit, and delayed unit minus postunit, percent differences were the same. An explanation of the assumptions I made before running these statistical tests can be found in Appendix W and a visual summary of my treatment of the quantitative data is in Appendix X.

## DATA AND ANALYSIS

I analyzed both quantitative and qualitative data obtained from a nontreatment unit and three treatment units to assess the effects of DI keys with analogies on my students' meaningful understanding of the biology concepts. These data were triangulated to address each project question in turn. Initially, I paired the postunit and preunit assessment data for my biology class as a whole, which allowed me to compare the differences in students' mean scores between the nontreatment, and three averaged, treatment units. I calculated two percent changes for this comparison, first a percent

change based on students' mean postunit and preunit assessment scores as a group using the percent change formula, and secondly, the percent difference, or mean percent change based on the score each student obtained as a postunit percent minus preunit assessment percent difference. I have included both calculations as samples in Appendix Y together with a rationale for basing my *t*-tests on the percent difference. These results are summarized in Table 2.

Table 2  
*Students' Mean Scores on Preunit and Postunit Assessments, (N = 20)*

Description of Data	Nontreatment (%)	Treatment Mean (%)
Preunit Mean	10.5	11
Postunit Mean	39.8	36.5
Percent Change	278	232
Percent Difference	29	26

Results indicate an increase in students' postunit assessment mean scores for both the nontreatment unit and treatment period average. A paired two-tailed *t*-test comparing the percent differences indicates no significant difference between the treatment period average ( $M = 25.5\%$ ) and the nontreatment unit mean ( $M = 29.3\%$ ),  $t(20) = 0.28$ ,  $p > 0.05$ ). Therefore, the observed difference can be attributed to chance based on my pre-established significance level of 95%. These data suggest that DI keys with analogies had little impact on my biology students' overall conceptual understanding. I have included this analysis as a sample *t*-test calculation in Appendix Y.

In addition to analyzing data from my biology class as a group, I compared the postunit and preunit assessment mean scores of six interviewed students, two each preselected from the low-, middle-, and high-achieving categories as determined by these students' most recent college science course or high school biology mark, whichever

grade was available. These data isolating changes in my interviewed students' conceptual understanding can be found in Table 3.

Table 3  
*Interviewed Students' Mean Scores on Preunit and Postunit Assessment Concept Interview Questions, (N = 6)*

Description of Data	Nontreatment (%)	Treatment Mean (%)
Preassessment	39	27
Postassessment	64	62
Percent Change	64	130
Percent Difference	25	35

Results indicate an increase in these six students' mean scores as a group for both the nontreatment unit and treatment period average. The percent difference for the treatment period was higher than that of the nontreatment unit, however, paired two-tailed *t*-tests were not used to quantify this increase due to: (a) the very small sample size ( $N = 6$ ) and (b) my nonrandom selection of these interviewed students from the class population. These data provide evidence of an increase in my interviewed students' conceptual understanding due to the use of DI keys with analogies.

I then separated my interviewed students by achievement category and compared the treatment period average of their mean scores to their nontreatment unit means.

These data isolating changes in their conceptual understanding can be found in Table 4.

Table 4  
*Interviewed Students' Preunit and Postunit Assessment Mean Scores by Academic Level, (N = 6)*

Description of Data	Nontreatment (%)				Treatment Mean (%)			
	Pre	Post	Change	Mean Change	Pre	Post	Change	Mean Change
High	38	69	84	32	23	62	169	38
Middle	44	50	15	6	27	53	96	26
Low	36	72	100	36	30	71	137	41

*Note.* Change = Percent Change, Mean Change = Percent Difference (by achievement category)

Results indicate an increase in the mean scores of students in all three achievement categories for both the nontreatment unit and the treatment period average. Both the percent changes and the percent differences for the treatment period average were higher than those for the nontreatment unit. These data suggest that my treatment teaching approach increased the understanding of biology concepts for students in all three achievement categories. Again, a small sample size and my nonrandom selection of these six students precluded the use of a paired two-tailed *t*-test to evaluate these observed increases for statistical significance.

Next, I examined any changes in my students' concept retention from the nontreatment unit to the treatment period by comparing their postunit assessment mean scores to the data collected from the delayed unit assessments administered two weeks later. These data isolating my students' long-term memory are found in Table 5.

Table 5  
*Students' Mean Scores on Postunit and Delayed Unit Assessments, (N = 20)*

Description of Data	Nontreatment (%)	Treatment Mean (%)
Postunit Mean	39.8	36.5
Delayed Unit Mean	35.2	38.9
Percent Change	-12	5.9
Percent Difference	-5	2

*Note.* Exact values (versus rounded figures) were used to calculate percent change.

Results indicate a significant difference between the nontreatment unit mean ( $M = -4.6\%$ ) and the treatment period average ( $M = 2.4\%$ ),  $t(20) = 2.56$ ,  $p < 0.05$ . As a group, my students not only retained, but achieved gains, in their biology knowledge after the

treatment period compared to after the nontreatment unit. These data provide evidence that my students' concept retention skills benefited as a result of my treatment teaching methods.

I then carried out a similar analysis of my interviewed students' long-term memory by comparing their postunit and delayed unit mean scores from my concept-specific interview questions. The results of this comparison are summarized in Table 6.

Table 6  
*Interviewed Students' Postunit and Delayed Unit Assessment Mean Scores by Academic Level, (N = 6)*

Description of Data	Nontreatment (%)				Treatment Mean (%)			
	Post	Delay	Change	Mean Change	Post	Delay	Change	Mean Change
High	75	46	-39	-29	62	65	5	3
Middle	50	42	-17	-8	58	<b>55</b>	<b>-5</b>	<b>-3</b>
Low	75	72	-4	-3	72	64	-10	-8

*Note.* Delay = Delayed Assessment, Boldfaced Type = Data Incomplete (based on only one student)

Results indicate a decrease in knowledge between the postunit and delayed unit assessments for students in all three achievement categories during the nontreatment unit, with my low-achieving students scoring closest to their postunit mean scores compared to the middle- and high-achieving students, respectively. In comparison, results appear reversed during the treatment period, with my high-achieving students making gains relative to both the middle- and low-achieving students. These data suggest that my middle- and high-achieving students' long-term memory benefited most from their use of DI keys.

Following these general comparisons between the nontreatment unit and treatment period averages, I proceeded to narrow down my analysis by pairing the mean scores within each unit as postunit minus preunit, and delayed unit minus postunit, assessment differences. The results of these paired two-tailed  $t$ -tests ( $k = 2$ ,  $\alpha = 0.05$ ) are summarized as  $p$ -values in Table 7. These results are significant, and reported in terms of the highest level of significance obtained, or insignificant, and therefore shown as equal to a specific  $p$ -value.

Table 7

*Comparison of Students' Mean Scores within Each Unit, (N = 20)*

Description of Data	Understanding	Long-term Memory
	Postunit minus Preunit	Delayed Unit minus Postunit
Percent Differences (%)		
Nontreatment Unit	29	-5
Treatment Unit 1	28	5
Treatment Unit 2	34	2
Treatment Unit 3	14	-1
<i>t</i> -statistics and Corresponding $p$ -values		
Nontreatment Unit	$t(20) = 6.66$ , $p < 0.001$	$t(20) = 1.13$ , $p = 0.27$
Treatment Unit 1	$t(20) = 6.92$ , $p < 0.001$	$t(20) = 2.20$ , $p < 0.05$
Treatment Unit 2	$t(20) = 5.94$ , $p < 0.001$	$t(20) = 0.15$ , $p = 0.88$
Treatment Unit 3	$t(20) = 3.46$ , $p < 0.01$	$t(20) = 0.23$ , $p = 0.82$

*Note.*  $p$  = maximum probability of an observed outcome occurring due to random events (Type 1 error)

Results indicate a significant increase in conceptual understanding within each unit from the preunit to postunit assessment period for all four units of study, with a less significant increase observed during Treatment Unit 3. There was a significant improvement in my students' postunit over preunit assessment mean scores given that the biology concepts I taught were new to most of my students. Evidence includes the typical responses I obtained on my preunit questionnaires, including "I don't know", no response (because

the student left the question blank), or the absence of an explanation required to justify a response to a multiple-choice question. With respect to long-term memory, the data only indicate a significant increase in my students' delayed unit over postunit assessment mean scores for Treatment Unit 1. These results suggest that as a group, although students' conceptual understanding did not change significantly because of my treatment teaching methods, their long-term memory skills did improve due to Treatment Unit 1.

After comparing the data within each unit of study, I paired each of the four units to compare students' performance on the assessments between units. Similar to the comparisons drawn within units, these comparisons isolated changes in students' conceptual understanding from the preunit to postunit, and postunit to delayed unit, assessment period. The data for these comparisons are summarized in Tables 8 through 11 in Appendix Z. With respect to conceptual understanding, my students' performance as a group during Treatment Unit 3 decreased significantly relative to all preceding units (see Table 8 in Appendix Z). While this trend is confirmed by the data obtained from my six interviewed students (see Table 9 in Appendix Z), these latter data further reveal that students in all three achievement categories made the greatest gains in their postunit knowledge during the period from the nontreatment unit to Treatment Unit 1. An increase from the nontreatment unit to Treatment Unit 1 is also indicated for both student groupings by the data for long-term memory (see Tables 10 and 11 in Appendix Z). That is, both my six interviewed students and the whole-class group retained (and achieved gains in their) knowledge as evidenced by significant increases in students' delayed unit ( $M = 5.40\%$ ) over postunit ( $M = -4.64\%$ ) assessment mean scores,  $t(20) = 3.38$ ,  $p < 0.05$ .

In addition to the data obtained from concept-specific assessments and student interviews, I analyzed quantitative and qualitative data from a Yes/No attitude scale. These data were used to measure any differences in my students' own perceived change in understanding of the biology concepts. I initially compared the quantitative data collected from the posttreatment survey to those of the pretreatment baseline. These data are summarized in Table 12.

Table 12  
*Effects on Students' Self-Perceived Understanding of Biology Concepts, (N = 20)*

Description of Data	Yes (better)	No (worse)	Total
Postunit Nontreatment	17	3	20
Postunit Treatment 3	17	3	20
Total	34	6	40

Results of the pretreatment and posttreatment survey indicate that, according to my students, both my initial teaching approach and the treatment learning strategies were effective in helping 85% of them better understand the biology concepts. There was no change ( $\chi^2 = 0$ ,  $p > 0.05$ ) between students' perceived understanding of the concepts from the pretreatment, to the posttreatment, period. Feedback on my posttreatment survey included a mixed response from one student, which I categorized as a negative (worse) outcome for the purpose of this analysis. These data provide evidence that, according to my students, my treatment teaching approach did not impact their overall understanding of the biology concepts.

Similarly, I then analyzed quantitative data from the Yes/No attitude scale developed to isolate changes in my students' self-perceived retention of the biology concepts. These data specific to long-term memory are displayed in Table 13.

Table 13  
*Effects on Students' Self-Perceived Long-Term Memory of Biology Concepts, (N = 20)*

Description of Data	Yes (better)	No (worse)	Total
Postunit Nontreatment	15	5	20
Postunit Treatment 3	17	3	20
Total	32	8	40

A chi-square analysis comparing the observed and expected (Yes = 16) response values confirms no significant difference ( $\chi^2$  Yates' = 0.156,  $p > 0.05$ ) between students' perceived retention of the biology concepts from the pretreatment, to the posttreatment, period. These results suggest that, according to my students, their long-term memory was unaffected by my intervention strategy. I have included this chi-square analysis as a sample calculation in Appendix Y.

Next, I analyzed qualitative data from my student attitude scale in the form of written comments accompanying each Yes/No response. This feedback specific to understanding and long-term memory is summarized in Table 14 according to the main themes I was able to identify.

Table 14  
*Students' Comments about Understanding and Long-Term Memory of Biology Concepts, (N = 20)*

Description of Data	Student's Response (T) = Typical (O) = Outlier
	Understanding
Pretreatment	I felt everything was well-explained. (T) The material and activities have been helping me understand the concepts. (T) I have learned to use some of the vocabulary properly. (O) I wish there was a bit more (materials and activities) on vocabulary. (O)
Posttreatment	The activities helped me use the vocabulary correctly. (T) The worksheets often included vocabulary I needed to know and helped me to understand the concepts more. (T)

	Having activities where we had to search for and write down definitions helped. (T) The dichotomous keys made it so you had to look up the vocabulary words and helped me remember them better. (O)
Long-term Memory	
Pretreatment	The notes and review before lessons is very helpful (for remembering). (T) Repetition and review has helped me most. (T) Some of the memory aids helped. (O) Talking about them (concepts) helped. (O) I don't seem to be retaining much. (O)
Posttreatment	Concepts were reinforced by usage in activities and assignments. (T) I would like worksheets like we had at the beginning of the term; I find I retain more. (T) I could remember more by learning about the vocabulary concepts on the board. (T) Making charts and comparisons helped so I could picture them (the concepts) later on. (T)

With respect to understanding of the pretreatment unit concepts, while 25% ( $n = 5$ ) of my biology students described the biochemistry concepts as difficult, most (75%) reported that my nontreatment teaching approach was effective in helping them understand and retain the concepts, especially my use of repetition and review activities. One student responded that “the way you review before every class and show us models and cartoon pictures is very helpful,” while a second student commented that “the drawings really help.” On the other hand, a third student stated that it [biochemistry] is “pretty straightforward stuff,” while a fourth student wrote that “there hasn’t been a lot of vocabulary so far [during the first two weeks].” Following the treatment period, students provided me with feedback on the impact of DI keys with analogies on their self-perceived understanding of the biology concepts. One student stated, “I have a better knowledge and use of the vocabulary,” but few students specifically reported this

increased understanding as a product of using DI keys or analogies. This is illustrated by a second student's comment that "the dichotomous keys didn't really help, but I liked the worksheets." Most of my students referred to the overall variety of learning activities I provided as the reason for their understanding and retention of the biology vocabulary.

I also analyzed the assignments my students created during the treatment period in the form of the DI keys collected in individual student folders. With each DI key, students were expected to include a single analogy for a concept of their choice. I reviewed their work to look for patterns and specific to conceptual understanding. A representative sample of my biology students' analogies can be found in Table 15.

Table 15

*Student-Generated Analogies for Biology Concepts, (N = 20)*

Description of Data	Analogy
Treatment Unit 1	<p>A polypeptide transported in a cell is like an air bubble in Jell-o®.</p> <p>Vesicles are to transport as planes are to an airport.</p> <p>A channel protein is to a molecule as tunnels are to cars.</p> <p>The use of active transport is like driving home instead of walking.</p> <p>A carrier protein is to a plasma membrane as a subway is to people.</p>
Treatment Unit 2	<p>Denaturation is to an enzyme as crumbling is to a brick wall.</p> <p>Cyanide is to an enzyme as kryptonite is to Superman.</p> <p>A coenzyme is to an enzyme as an employee is to an employer.</p> <p>An enzyme is to a chemical reaction as a gas pedal is to a car.</p> <p>A competitive inhibitor is to an enzyme as cholesterol is to an artery.</p>
Treatment Unit 3	<p>Stomata are to a leaf as gills are to a fish.</p> <p>Using 2ATP to start glycolysis is like investing money to make more money.</p> <p>Photosynthesis is to plants as solar energy is to houses.</p> <p>Electron transport chains are like assembly lines.</p> <p>Aerobic cellular respiration is to cells as breathing is to humans and other mammals.</p> <p>Negative feedback is to homeostasis as a return plane ticket is to home.</p>

Results indicate consistency across the treatment units in students' abilities to make clear and useful comparisons between biology target concepts and more familiar analogs from everyday life. While most students generally followed the format of "A is to B as X is to Y" when making their comparisons, others created a successful simile, such as the student whose analogy compared electron transport chains to assembly lines (see Table 15). In comparison, some students' analogies were potentially confusing to a reader in that they appeared to conjure more differences than similarities to the target concept. For instance, one student compared metabolism to the downloading of an email (see Series 5 Treatment Unit 3 in Appendix AB). My students also occasionally forgot to include an analogy with their assignments (see Series 4 Treatment Unit 3 in Appendix AB), so the data record is incomplete in terms of having an analogy for each DI key I collected.

In comparison to their analogies, students' DI keys indicate an improved ability over time to identify similarities and differences between two concepts branching from a more general concept in the hierarchy. I have included a series of individual students' DI keys across the three treatment units to represent the works of both my interviewed students and other students from my biology class. These samples of student-generated DI keys are found in Appendix AB. They provide a record of how my students did or did not demonstrate a meaningful understanding of the treatment period concepts. An example of an individual succeeding in his understanding is one student's acknowledgment that higher temperature can both increase and decrease catalysis depending on whether or not the specific enzyme has been denatured by the addition of heat (see Series 4 Treatment Unit 2 in Appendix AB). In contrast, an example of a

student falling short in her understanding includes her inability at one point in time to complete the branching process for exocytosis; she could have identified proteins and lipids as two different macromolecules that exit the cell by way of active transport in vesicles (see Series 1 Treatment Unit 2 in Appendix AB).

I also compared my interviewed students' responses to the preunit and postunit interview questions from the nontreatment unit to the treatment period. Students' answers to my interview questions did not appear to change discernibly across the units in terms of depth of understanding of the biology concepts. For example, one student's preunit assessment response to the nontreatment unit question, 'What is a polypeptide and what does it do?' included, "It is a chain of amino acids linked by peptide bonds; I don't remember what it does." Her postunit assessment response to this question was similar, "It is a chain of amino acids linked by peptide bonds; a polypeptide can be a hormone or transport molecule." At the start of Treatment Unit 2, this particular student responded to the preunit assessment question, 'What is osmosis', with the statement, "It has something to do with water," while in her postunit assessment response she replied, "Osmosis is the movement of water across a cell membrane." In general, I found that my interviewed students responded to the preunit questions with "I don't know", while their postunit responses reflected basic knowledge they had acquired as part of the direct instruction I provided during lecture and lab lessons. That is, most of the course content presented in biology class was new to my interviewed students with the exception of the student described above; she had recently completed the equivalent course in high school

and retained some prior knowledge that the other interviewed students lacked at the preunit assessment stage.

In addition to answering short-response questions, my interviewed students created concept maps. These concept maps indicate similar levels of understanding of the biology vocabulary from the preunit, to the postunit, period for both the nontreatment, and treatment, units. This is evidenced by the consistent percentage of supplied vocabulary concepts students used in their maps and by the number of valid links they made between the concepts. During implementation of DI keys, I did notice a tendency of these six students to dichotomize their concept maps even though the concept-mapping guidelines allowed for much greater flexibility in format. This is evidence that my students were not only attempting to understand the biology concepts, but that they were also internalizing the process of creating DI keys.

Finally, I considered my own journal entries and responses to the attitude scale questions I completed before and during implementation for evidence of my intervention's impact on students' conceptual understanding and long-term memory. My comments and responses do not indicate any discernible change, either positive or negative, in my students' understanding and retention of the biology concepts as a direct result of having used DI keys with analogies for eight weeks.

After analyzing the impact of my treatment teaching approach on my biology students' understanding and long-term memory, I addressed my remaining project subquestions, which were designed to isolate and evaluate its effects on students' higher-order thinking skills, attitudes, and motivation to learn.

First, I compared students' postunit and preunit assessment mean scores by question complexity (see Appendix D). These data isolating changes in my students' lower- and higher-order thinking skills as a group are summarized in Table 16.

Table 16

*Comparison of Preunit and Postunit Assessment Mean Scores by Question Type, (N = 20)*

Description of Data	Nontreatment (%)				Treatment Mean (%)			
	Pre	Post	Change	Mean Change	Pre	Post	Change	Mean Change
Lower-order	22	51	134	29	13	50	473	37
Higher-order	5	36	663	32	9	29	387	20

*Note.* Lower-order = Remember/Understand/Apply, Higher-order = Analyze/Evaluate/Create

Results of a comparison within cognitive level indicate a significant increase in students' preunit to postunit assessment performance on my lower-order questions from the nontreatment unit ( $M = 29.38\%$ ) to the treatment period average ( $M = 37.29\%$ ),  $t(20) = 4.98$ ,  $p < 0.001$ . In contrast, the data indicate a significant decrease in the preunit to postunit assessment scores from the nontreatment unit ( $M = 31.50\%$ ) to the treatment period mean ( $M = 20.15\%$ ) with respect to the higher-order questions,  $t(20) = 6.14$ ,  $p < 0.001$ . I then used paired two-tailed  $t$ -tests to quantify any differences observed between the two cognitive levels. A comparison of the percent difference data for my lower- ( $M = 29.38\%$ ) and higher-order ( $M = 31.50\%$ ) questions indicates no significant difference between the results for the two knowledge levels during the nontreatment unit,  $t(20) = 0.37$ ,  $p = 0.71$ ). In contrast, a significantly higher mean score was observed on the lower-order questions ( $M = 37.40\%$ ) than on the higher-order questions ( $M = 20.04\%$ ) during the treatment period,  $t(20) = 5.28$ ,  $p < 0.001$ . These data suggest that my treatment

methods increased students' lower-order thinking skills while negatively impacting their higher-order thinking skills.

Similarly, I compared the preunit and postunit assessment mean scores for my interviewed students as a group based on the cognitive level of my concept-specific questions. These data are summarized in Table 17.

Table 17  
*Interviewed Students' Mean Scores on Preunit and Postunit Assessment Concept Interview Questions by Cognitive Level, (N = 6)*

Description of Data	Nontreatment (%)				Treatment Mean (%)			
	Pre	Post	Change	Mean Change	Pre	Post	Change	Mean Change
Lower-order	39	67	71	28	21	62	187	40
Higher-order	39	57	44	17	42	59	41	17

*Note.* Lower-order = Remember/Understand/Apply, Higher-order = Analyze/Evaluate/Create

Results indicate an increase in my interviewed students' mean scores on the lower-order questions during the treatment period and no overall change in their responses on the higher-order questions. These data provide further evidence that my treatment methods positively impacted students' lower-order thinking skills.

Next, as with conceptual understanding and long-term memory beforehand, I narrowed down my analysis to compare the data for the two cognitive levels within, and between, my four units of study. The first comparison drawn was within units for my biology students as a whole group. These data isolating lower- and higher-order thinking skills within each unit can be found in Table 18.

Table 18  
*Comparison of Students' Mean Scores within Each Unit (Cognitive Level), (N = 20)*

Description of Data	Lower-order	Higher-order
	Postunit minus Preunit	Postunit minus Preunit
Percent Differences (%)		
Nontreatment Unit	29	32
Treatment Unit 1	57	17
Treatment Unit 2	37	33
Treatment Unit 3	18	11
<i>t</i> -statistics and Corresponding p-values		
Nontreatment Unit	$t(20) = 4.98, p < 0.001$	$t(20) = 6.14, p < 0.001$
Treatment Unit 1	$t(20) = 7.66, p < 0.001$	$t(20) = 3.90, p < 0.001$
Treatment Unit 2	$t(20) = 4.78, p < 0.001$	$t(20) = 5.31, p < 0.001$
Treatment Unit 3	$t(20) = 3.35, p < 0.01$	$t(20) = 2.74, p = 0.013$

Results indicate significant increases in students' postunit assessment mean scores within each unit on both the lower- and higher-order questions, with a less significant result observed for my lower-order questions during Treatment Unit 3. These data suggest that, as a group, my biology students' lower-order thinking skills increased the most immediately after initial implementation of DI keys with analogies. In comparison, decreases in students' higher-order thinking skills were observed during both Treatment Units 1 and 3.

My next analysis consisted of comparing students' preunit and postunit assessment mean scores across the various units in all six combinations by isolating both lower- and higher-order thinking skills in turn. The data for these comparisons are summarized in Tables 19 and 20 in Appendix AA. Results indicate: (a) a significant increase in my students' mean scores on the lower-order questions from the nontreatment unit ( $M = 29.38\%$ ) to Treatment Unit 1 ( $M = 57.00\%$ ),  $t(20) = 3.84, p < 0.01$ , and (b) a significant decrease in my students' mean scores on the higher-order questions between

the nontreatment unit ( $M = 31.50\%$ ) and both Treatment Units 1 ( $M = 16.75\%$ ) and 3 ( $M = 10.94\%$ ), respectively,  $t(20) = 2.70$ ,  $p < 0.05$ ;  $t(20) = 4.47$ ,  $p < 0.001$ . If compared to each other, the results for the two cognitive levels suggest that my treatment methods may have increased my students' lower-order thinking abilities at the expense of their higher-order thinking skills during Treatment Unit 1, although no cause-and-effect relationship has been established.

I completed the analysis of my concept-specific assessments by creating a graphic to visually summarize the effects of my treatment period teaching approach on students' understanding, long-term memory, and both lower,- and higher-order, thinking skills. Figure 1 combines the data from Tables 18 through 20 and thus compares all four variables for my biology students as a group.

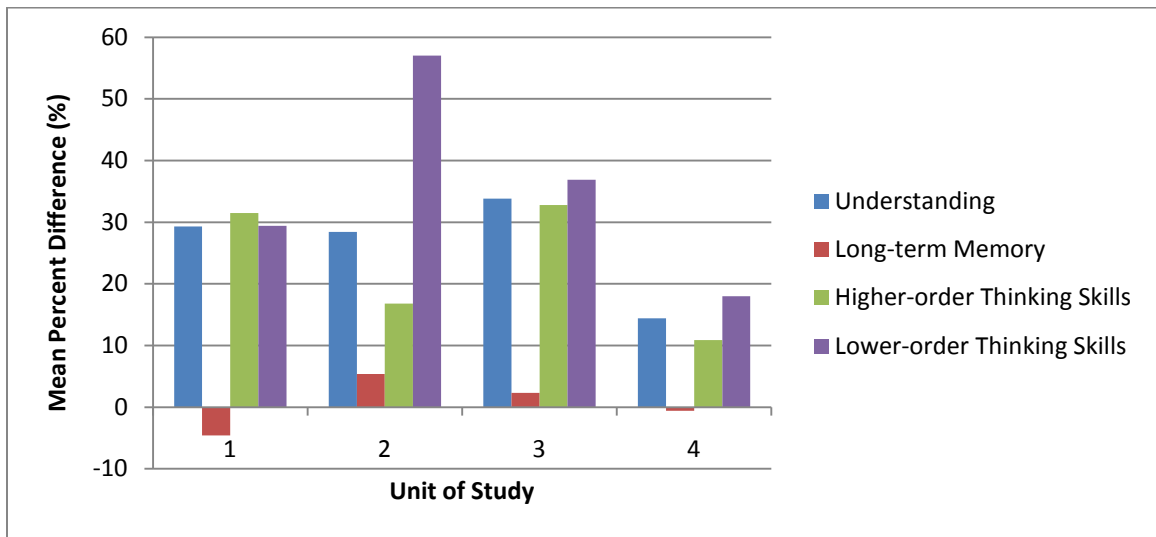

*Figure 1.* Comparison of effects on biology students' cognitive skills by mean percent difference, ( $N = 20$ ).

*Note.* 1 = Nontreatment, 2-4 = Treatment Units 1-3, Long-term memory = delayed unit minus postunit (versus postunit minus preunit) assessment comparison

Figure 1 shows a transient increase in my students' lower-order thinking skills amid an overall negative trend in addition to an improvement in students' long-term memory skills.

Next, I analyzed quantitative and qualitative data from a Yes/No attitude scale. These data were used to measure the effects of my treatment period lessons on students' self-perceived change in cognitive ability. Quantitative data from the posttreatment survey were initially compared to the pretreatment baseline. These data are summarized in Table 21.

Table 21  
*Effects on Biology Students' Self-perceived Higher-Order Thinking Skills, (N = 20)*

Description of Data	Yes (better)	No (worse)	Total
Postunit Nontreatment	15	5	20
Postunit Treatment 3	18	2	20
Total	33	7	40

Results indicate no significant difference ( $\chi^2$  Yates' = 0.693,  $p > 0.05$ ) between students' perceived higher-order thinking skills from the pretreatment, to the posttreatment, period. Three students whose responses I categorized as negative after the nontreatment unit subsequently self-reported an improvement in their higher-order thinking skills at the end of the implementation period. These three students account for the differences observed in Table 19. One of these students who changed her mind commented, "Eventually, I found it easy to pull all the units together to understand enzyme-catalyzed digestion." In contrast, a second student responded to the question of whether she felt her higher-order thinking skills had improved by simply stating, "No, not really." These data suggest that,

according my students, my treatment methods had no affect on their higher-order thinking skills.

After determining the effects of my treatment period teaching approach on students' cognitive abilities, I turned my attention to its impact on their affective knowledge. Using a composite of four questions from my attitude survey, I was able to assess each student's overall attitude before and after the treatment period and assign him or her to one of two categories, either 'better' or 'worse'. These data summarizing my students' general feelings about biology are found in Table 22.

Table 22  
*Effects on Biology Students' Attitude Toward Biology, (N = 20)*

Description of Data	Yes (better)	No (worse)	Total
Postunit Nontreatment	20	0	20
Postunit Treatment 3	17	3	20
Total	37	3	40

Results indicate no significant difference ( $\chi^2$  Yates' = 3.751,  $p > 0.05$ ) between students' general attitudes toward biology, although three students did record two or more negative comments on their posttreatment surveys. One of these students noted, "It seemed like we were going really fast." These data provide evidence that DI keys with analogies had no impact on my students' overall like or dislike of biology.

Similarly, I compared students' overall motivation to learn both before and after the treatment period by using a three-question composite to assess their interest in biology class. These data can be found in Table 23.

Table 23  
*Effects on Students' Motivation to Learn Biology, (N = 20)*

Description of Data	Yes (better)	No (worse)	Total
Postunit Nontreatment	18	2	20
Postunit Treatment 3	18	2	20
Total	36	4	40

Results indicate no change ( $\chi^2 = 0$ ,  $p > 0.05$ ) in students' overall motivation. While two of my students expressed increased motivation, two others reported a decreased interest. One of the students whose motivation improved stated, "At this point we are learning about body systems and functions, which is interesting." In comparison, a student whose interest level decreased commented that my labs didn't motivate her as much as the lectures. These results suggest that, as with attitude, DI keys with analogies had no significant impact on my biology students' overall motivation.

Although most students responded with positive attitudes and motivation about biology class as a whole, the written comments on my posttreatment survey specific to the use of DI keys and analogies yielded highly polarized responses from my students as a group. I have included a representative sample of the written feedback they provided in Appendix AC. These comments indicate most of my students either felt very positive about my intervention's effects on their understanding, attitude, and motivation, or conversely, they felt very negative. Only two students recorded neutral comments about the effects of DI keys on their motivation and like or dislike of biology. One of these two students wrote, "DI keys and analogies didn't change how I feel about biology." The polarizing effect of my intervention on attitudes and motivation is supported by the trend

in the number of DI keys students completed and turned in during the treatment period.

These data can be found in Table 24.

Table 24

*Motivation of Biology Students as Evidenced by Number of Dichotomous Keys, (N = 20)*

Description of Data	Nontreatment	Treatment 1	Treatment 2	Treatment 3
Percentage of Students (%)	-	85	70	70 60

The data indicate fewer biology students submitted DI keys as the treatment period progressed, including two students who did not submit a single assignment for feedback.

These data provide evidence that: (a) my intervention strategy was disliked by some students from the start, and (b) prolonged implementation alienated an increasing number of students.

In addition to the comments provided by my students on their attitude scales, I also considered the feedback I received from my classroom observer, which was based on eight separate classroom visits. I compared Dr. Laura Cooper's feedback to the daily comments I made in my teaching journal and to the teacher attitude scales I completed at following the completion of each unit. These comments not only focused on student and teacher attitude and motivation, but also on my time management and teaching. Results indicate I maintained a highly positive attitude in class throughout the 10 weeks of my project implementation period despite both student and teacher fatigue setting in at the end of the treatment period. Furthermore, my observer and I both noticed a dichotomy in the level of student engagement caused by DI keys, as evidenced by Laura's comment, "Those students who did the assignment [as homework] appeared to generally have a

positive learning experience even if they made errors.” In this particular instance, a significant number of students had failed to bring a rough draft to class for editing.

I completed my analysis of the data by focusing on the potential impact of DI keys with analogies on my own teaching, time management, and attitude, which consisted of identifying any patterns and trends discernible in the comments I had recorded in my daily teaching journal. Concerning my teaching, I noted the increased time I was able to devote to discussion with individual students as they worked on their DI keys, which was a direct consequence of less time engaged in direct instruction (ie. note-taking).

Secondly, with respect to time management, teaching students how to create analogies and DI keys required more class time than my regular teaching approach, but besides the initial development of resources needed for this study, my lesson preparation time was unaffected. However, had I not photocopied two day’s worth of lecture notes to distribute to my students, I would have lost about one week of instructional time over the 8-week duration of the treatment period. I have included a comparison of my preimplementation and implementation timeline in Appendix V. This comparison indicates little change in my course timeline given the proactive step taken above, albeit my comments still indicate I consistently felt pressured to complete the learning activities in the allotted time. On the other hand, the initial anxiety I felt in giving up my existing teaching approach was gradually replaced by the confidence that I could still cover the course content and use my traditional methods after investing the time to teach students how to make and use my intervention strategies. During implementation, DI keys with

analogies evolved into a teaching tool that might be used in a variety of ways as follows: as a whole-class or small-group unit review activity; as a shorter exercise involving brainstorming and peer-editing sessions during regular lecture and lab lessons; and as a weekly-assigned individual homework task. One notable change to my planned methodology was to respect my adult students' life circumstances by assigning only individual DI keys for homework completion; verbal feedback from a number of students as they created their first practice DI key with a partner indicated that it was too difficult for some students to collaborate with their peers outside of class time.

Thirdly, with respect to attitude, I considered my daily responses to the Yes/No statement, 'My attitude regarding this lesson is positive', by comparing the number of positive and negative responses recorded in my teaching journal during the nontreatment, and treatment, period. Although the data indicate I felt positive about my nontreatment lessons 80% of the time (over five lessons) and positive about the treatment lessons 70% of the time (over 21 lessons), a chi-square analysis reveals no significant difference ( $\chi^2$  Yates' = 0.232,  $p > 0.05$ ) between the pretreatment, and treatment, period. In comparison, as implementation progressed, I did record a written comment in my journal about my self-perceived inability to motivate the increasing number of students who were tiring of my DI keys.

## INTERPRETATION AND CONCLUSION

The extensive data I obtained from a nontreatment, and three treatment, units provided me with solid evidence on which to base a response to my focus question.

Triangulation of the data suggests that DI keys with analogies had no overall positive or negative impact on students' self-perceived, nor actual, understanding of the biology concepts as a class group, with the exception of the decrease in postunit assessment mean scores I observed during Treatment Unit 3. I attribute this decrease to student fatigue after eight weeks of intensive use of DI keys, which is supported by both verbal and written feedback obtained from my students. In comparison to my biology class as a whole, the data from my interviewed students suggest that students in all three achievement categories made gains in their understanding during the treatment period. This difference might be explained by the small sample size these six students represented. In hindsight, a more accurate method of determining student achievement level would have been to administer a short diagnostic test to all of my students on the first day of class instead of relying on their past grades in other science or biology courses.

The data I obtained also allowed me to draw reliable conclusions about the effects of my treatment methods on students' long-term memory, higher-order thinking skills, attitudes, and motivation. In comparison to understanding, there was a significant improvement in my biology students' long-term memory from the nontreatment unit to the treatment period. Both my interviewed students and class group as a whole experienced gains after Treatment Unit 1. This initial effect of my treatment approach on concept retention is promising and merits further investigation.

Although my students' overall understanding appears to have remained unchanged as a class group, dividing the assessment data into lower- and higher-order

questions reveals a different picture. A decrease in my students' higher-order thinking skills during the treatment period was offset by an unexpected increase in lower-order thinking ability, a result which can be attributed to a transient significant increase in students' postassessment mean scores during Treatment Unit 1. These results suggest that, although my students may have used higher-order thinking skills to construct and revise their DI keys, both the structure and administration of my unit assessments may have contributed to the decrease observed in higher-order cognition during the treatment period. I hypothesize that this decrease in higher-order thinking skills was in part due to the insufficient class time and response space I provided for students to complete the open-ended questions on these assessments. These results also suggest that my nontreatment teaching approach of thoroughly explaining, reviewing, and spiralling concepts may be more effective in developing biology students' lower- and higher-order thinking skills than my intervention strategy. Furthermore, they suggest that DI keys and analogies initially required my students to exert greater individual effort to learn the basic vocabulary as they researched concepts to include in their DI key assignments. While the data for my six interviewed students suggest no change in higher-order thinking ability, they also support the aforementioned conclusion that students' lower-order thinking skills improved due to the variety of learning strategies I employed during the treatment period.

DI keys with analogies had a marked impact on my biology students' attitudes and motivation to learn. While their general like of, and interest in, biology class and my teaching of it remained positive, my intervention strategy polarized most of my students so that they fell into one of two categories. One group disliked the time, subjectivity, and

frustration involved in creating DI keys with analogies, while the other group enjoyed and/or saw an educational value in the project-related activities. These results suggest that my prolonged use of DI keys: (a) amplified the differences in my students' learning preferences and learning styles, and (b) highlighted the differences in their abilities to tolerate and embrace ambiguity during the learning process.

My implementation of DI keys with analogies also revealed a need for me to set aside more class time when teaching and using a constructivist learning model. Were it not for a deliberate reduction in the amount of time spent in direct instruction during my study, I estimate that I would have been able to cover one fewer human body system during the second half of the term.

Through the constructive criticism offered by students whose attitude and motivation were negatively affected, I learned that DI keys do not appeal to all students equally, and that their application should be restricted to concepts that most readily lend themselves to the process of branching in two. For example, my students found it easier to dichotomize membrane transport and enzymes than they did organelles and cell division. In addition, I have since discovered that several topics covered outside of the treatment period, such as biological molecules (during the nontreatment unit) and human body systems (after project completion), are actually better suited to DI keys than some of the concepts I taught during my treatment units. Finally, one of my students suggested an improvement in the design of my unit assessments. I should have stated that the higher-order questions would be scored out of four marks, for had he known this from the start, he would have included more detail in his written explanations.

## VALUE

This study has provided me with greater insight about my existing teaching approach as well as about the potential applications of DI keys with analogies in my future biology classes. By introducing significant change into the way my students learn the vocabulary, students revealed what did and did not work well for them. That is, they identified aspects of my pretreatment teaching approach that are highly effective, as well as the strengths and weaknesses of my intervention strategy, especially the manner in which I implemented it. Supported by my detailed analysis of the data, I learned that DI keys with analogies show promise as a means of improving biology students' lower-order thinking skills and long-term memory. Furthermore, the qualitative and quantitative data reminded me that DI keys and analogies should be used along with a variety of other traditional and constructivist learning strategies. This will ensure that students whose learning styles and preferences are not targeted by a new intervention do not become disengaged due to my overuse of one learning tool.

Based on my experience during this study, I hypothesize that DI keys with analogies might be useful to instructors of other high school and college-level science and humanities courses. Whether as the hybrid learning strategy I envisioned, or as two distinct formative assessment tools, educators could use DI keys as a graphic organizer to introduce, practice, and review course content. For example, math students could create a visual summary by identifying rational and irrational numbers as the first branch in a hierarchy of real numbers. Chemistry teachers might organize bonding along the lines of ionic versus covalent compounds. In geology, sedimentary rocks could be separated

from metamorphic and igneous rocks, both of which have been altered by high heat. In physics, the transfer of heat by radiation could be distinguished from conduction and convection, which both require the presence of matter. Furthermore, specific concepts in science textbooks might be introduced or summarized through the use of a DI key. As an extension beyond the science classroom, one potential application in the humanities includes differentiating the types of conflict in a story according to external and internal forms of struggle. That is, man versus environment is impersonal, while both man versus himself (intrapersonal) and man versus man (interpersonal) could be classified as personal interactions.

In conclusion, I would improve my study's overall design by using two separate, yet concurrently offered, sections of the same biology course to verify the outcome. That is, how would my results compare if one group were taught using only my prior teaching methods throughout the implementation period while the other group used DI keys with analogies as the main learning strategy from beginning to end? As a first foray into action research, this investigation not only taught me about the potential uses of DI keys and analogies in science education, but perhaps more importantly, helped develop my professional competency in the methods I can use to evaluate my teaching and students' learning in the future. For as the Committee on Learning Research and Educational Practice of the National Research Council recommends in its publication entitled *How People Learn: Bridging Research and Practice* (1999), "both quantitative and qualitative procedures of substantial rigor" are essential in order to "build an effective bridge between research and practice" (p.31). And finally, as a graduate student and a teacher,

my work on this capstone project has not only reinforced my personal commitment to lifelong learning, but it has also more fully cultivated the awareness within me that I belong to a world community of learners with the responsibility to share what I have learned.

## REFERENCES CITED

- Ajzen, I. (2001). Nature and operation of attitudes. *Annual Review of Psychology*, 52, 27-58.
- Allan, R. E. (Ed.) (1990). *The concise Oxford dictionary of current English* (8<sup>th</sup> ed.). New York: Oxford University Press.
- Anderson, L. W., & Krathwohl, D. R. (2001). *A taxonomy of learning, teaching and assessing: A revision of Bloom's taxonomy of educational objectives*. New York: Longman.
- Angelo, T. A., & Cross, K. P. (1993). *Classroom assessment techniques: A handbook for college teachers*. (2nd ed.). San Francisco: Jossey-Bass.
- Bavis, R. W., Seveyka, J., & Shigeoka, C. (2000). Another strategy for teaching histology to A&P students: Classification versus memorization. *The American Biology Teacher*, 62(5), 365-369.
- Bloom, B. S. (1956). *Taxonomy of educational objectives: The classification of educational goals; Handbook I, cognitive domain*. New York: David McKay.
- Bloom, B. S. (1964). *Taxonomy of educational objectives: The classification of educational goals; Handbook 2: Affective domain*. New York: Longman.
- Bransford, J. D., Brown, A. L., & Cocking, R. R. (Eds.) (2000). *How people learn: Brain, mind, experience, and school*. Washington, DC: National Academy Press.
- Donovan, M. S., Bransford, J. D., & Pellegrino, J. W. (Eds.) (1999). *How people learn: Bridging research and practice*. Washington, DC: National Academy Press. Retrieved April 21, 2011, from <http://www.nap.edu/catalog/9457.html>.
- Doran, R., Chan, F., Tamir, P., & Lenhardt, C. (2002). *Science educator's guide to laboratory assessments*. Arlington, VA: NSTA Press.
- Flavell, J. H. (1979). Metacognition and cognitive monitoring: A new area of cognitive development inquiry. *American Psychologist*, 34(10), 906-911.
- Gardner, H. (2008a). *Five minds for the future*. Boston: Harvard Business Press.
- Gardner, H. (2008b). Frequently asked questions, multiple intelligences and related educational topics. Rev 07-2004, Howard Gardner. Retrieved April 30, 2010, from: <http://www.howardgardner.com/FAQ/FREQUENTLY%20ASKED%20QUESTIONS%20Updated%20March%202009.pdf>

- Gobalet, K. (2003). An alternative exercise for generating a dichotomous key to vertebrae. *The American Biology Teacher*, 65(9), 697-700.
- Goswami, U. (2008). Principles of learning, implications for teaching: A cognitive neuroscience perspective. *Journal of Philosophy of Education*, 42(3-4), 381-399.
- Jofili, Z., Geraldo, A., & Watts, M. (1999). A course for critical constructivism through action research: A case study from biology. *Research in Science and Technological Education*, 17(1), 5-17.
- Kagan, D. M. (1992). Implications of research on teacher belief. *Educational Psychologist*, 27(1), 65-90.
- Kearns, H., & Gardiner, M. (2007). Is it time well spent? The relationship between time management behaviours, perceived effectiveness and work-related morale and distress in a university context. *Higher Education Research and Development*, 26(2), 235-247.
- Kinchin, I. (2000). Concept mapping in biology. *Journal of Biological Education*, 34(2), 61-68.
- Kinchin, I. (2001). If concept mapping is so helpful to learning biology, why aren't we all doing it? *International Journal of Science Education*, 23(12), 1257-1269.
- Kitchen, E., Reeve, S, Bell, J.D., Sudweeks, R.R., & Bradshaw. W.S. (2007). The development and application of affective assessment in an upper-level cell biology course. *Journal of Research in Science Teaching*, 44(8), 1057-1087.
- Lauer, T. (2005). Teaching critical thinking skills using course content material: A reversal of roles. *Journal of College Science Teaching*, 34(6), 34-37.
- Mansour, N. (2008). Science teachers' beliefs and practices: Issues, implications and research agenda. *International Journal of Environmental & Science Education*, 4, 25-48.
- Middleton, J. (1991). Student-generated analogies in biology. *The American Biology Teacher*, 53(1), 42-46.
- Mintzes, J., Wandersee, J., & Novak. J. (2001). Assessing understanding in biology. *Journal of Biological Education*, 35(3), 118-124.
- Novak, J. D. (2004). Reflections on a half-century of thinking in science education and research: Implications from a twelve-year longitudinal study of children's learning. *Canadian Journal of Science, Mathematics, and Technology*, 4(1), 23-41.

- Novak, J. D., & Cañas, A. J. (2008). The theory underlying concept maps and how to construct them, technical report IHMC CMapTools 2006-01 Rev 01-2008, Florida Institute for Human and Machine Cognition. Retrieved May 3, 2010, from: <http://cmap.ihmc.us/Publications/ResearchPapers/TheoryUnderlyingConceptMaps.pdf>
- Orgill, M., & Bodner, G. (2007). Locks and keys: An analysis of biochemistry students' use of analogies. *Biochemistry and Molecular Biology Education*, 35(4), 244-254.
- Osborne, R., & Freyberg, P. (1985). *Learning in science: The implications of children's science*. Auckland: Heinemann Education.
- Rogers, W. D., & Ford, R. (1997). Factors that affect student attitude toward biology. *Bioscene*, 23(2), 3-5.
- Rose, N. S., Myerson, J., Roediger, H. L. III, & Hale, S. (2010). Similarities and differences between working memory and long-term memory: Evidence from the levels-of-processing span task. *Journal of Experimental Psychology: Learning, Memory, and Cognition*, 36(2), 471-483.
- Shavelson, R. J., Young, D. B., Ayala, C. C., Brandon, P. R., Furtak, E. M., & Ruiz-Primo, M. A. (2008). On the impact of curriculum-embedded formative assessment on learning: A collaboration between curriculum and assessment developers. *Applied Measurement in Education*, 21, 295-314.
- Šorgo, A. (2006). Dichotomous identification keys: A ladder to higher order knowledge about the human body. *Science Activities*, 43(3), 17-20.
- Venville, G. J., & Treagust, D. F. (1997). Analogies in biology education: A contentious issue. *The American Biology Teacher*, 59(5), 282-287.
- Watson, S., & Miller, T. (2009). Classification and the dichotomous key: Tools for teaching identification. *The Science Teacher*, 76(3), 50-54.

APPENDICES

APPENDIX A

SAMPLE APPROXIMATE ANALOGIES (CO-INTERVENTION STRATEGY)

## EVERYDAY EXAMPLES

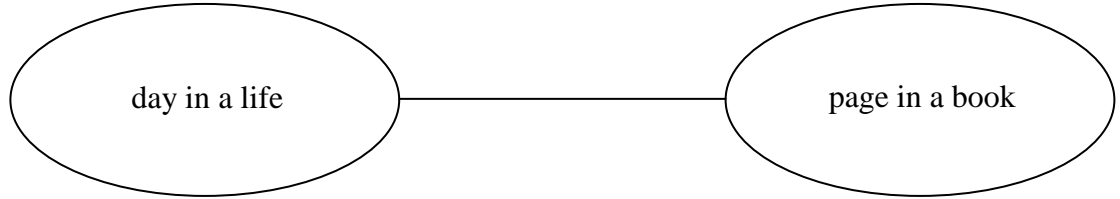

A day is to a life as a page is to a book.

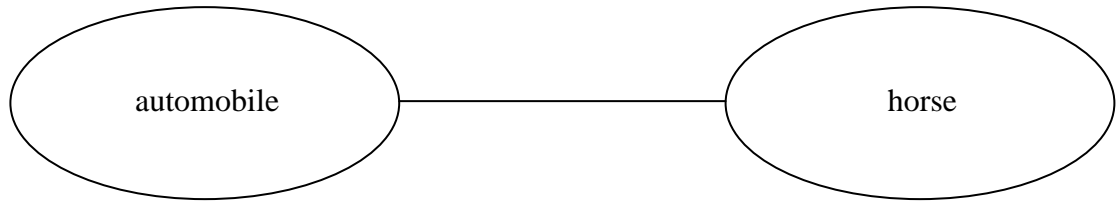

The automobile is to modern life as the horse was to the Old West.

## SCIENCE-RELATED EXAMPLES

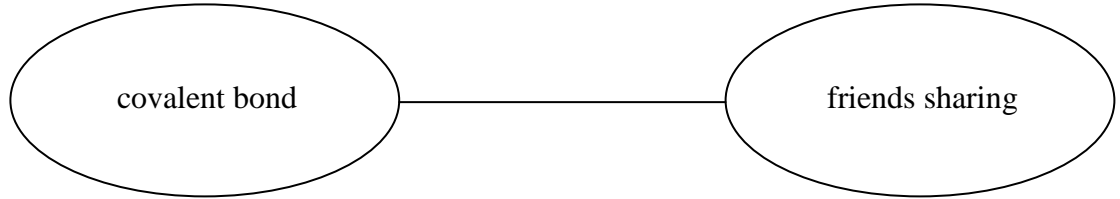

A covalent bond is to a compound of two non-metals as sharing is between close friends.

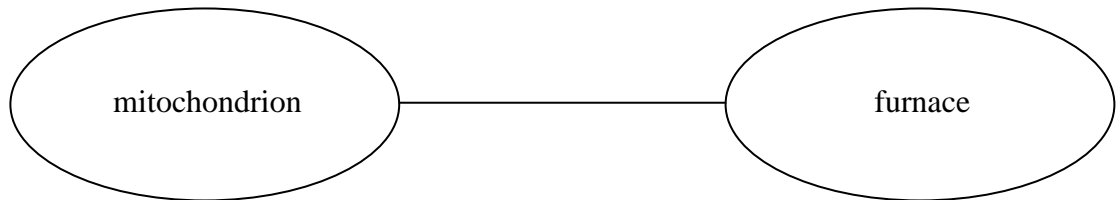

The mitochondrion is to a eukaryotic cell as a furnace is to a house.

APPENDIX B

SAMPLE DICHOTOMOUS KEY (MAIN INTERVENTION STRATEGY)

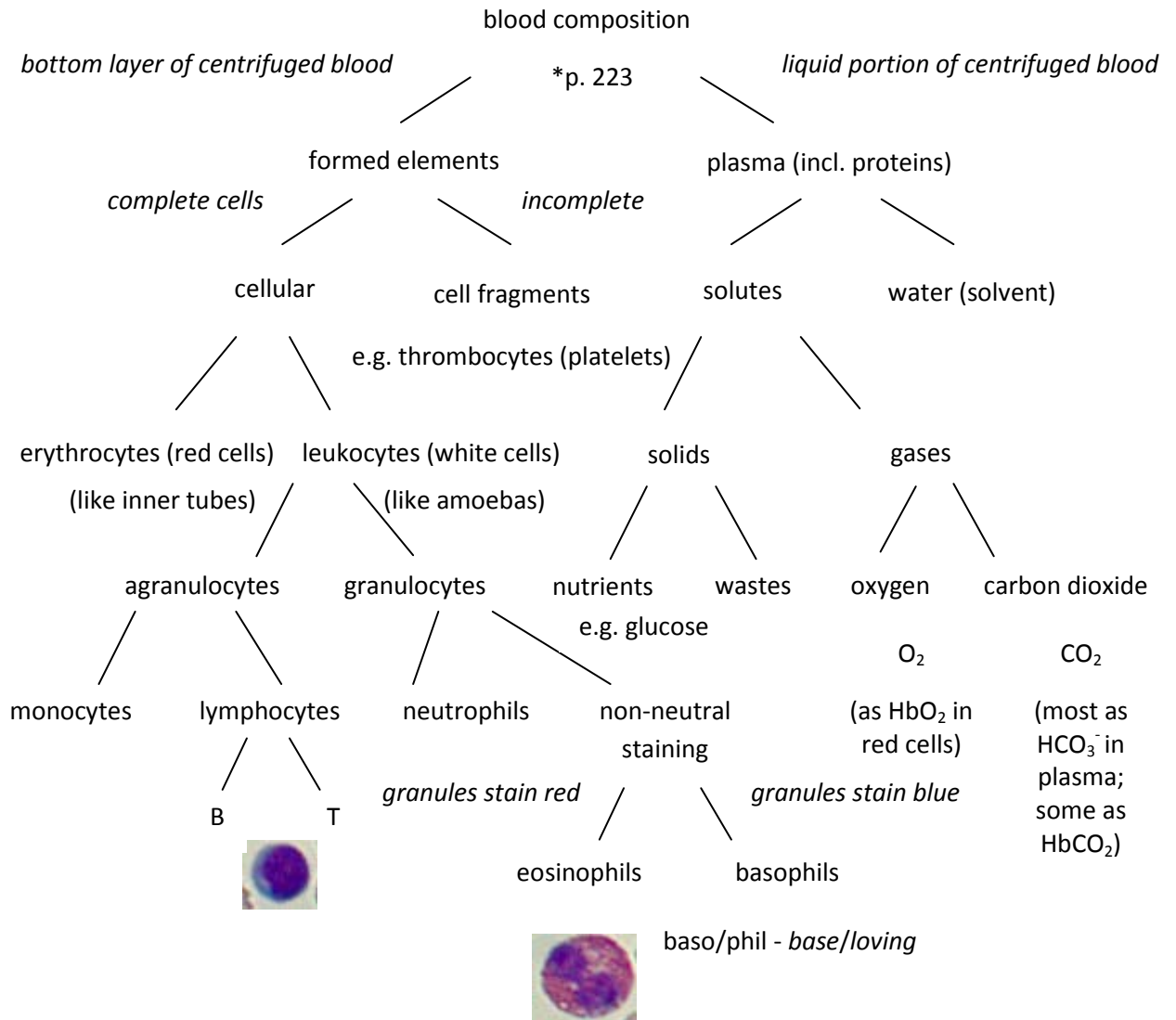

\*Mader, S. (2011). *Inquiry into Life* (13<sup>th</sup> ed.). New York: McGraw-Hill.

Photo Credits: R. Tillman

Note: I created this sample DI key to illustrate my intervention strategy to the reader. It contains several more branching levels than I expected my students to include in their first DI keys. Due to lack of space, I have omitted most of the criteria used to divide each category, as well as most analogies, examples, word origins, textbook page references, and sketches. This DI key is based on the level of understanding that a high-achieving student in my college-level introductory biology course should possess after completing the circulatory system chapter.

APPENDIX C

PROJECT DEFINITIONS AND FRAMES OF REFERENCE

### Relevant Project Subthemes

The literature recommends a shift in instructional approaches from having students memorize and recall factual knowledge to instead helping them develop their capacity to access this knowledge. This shift in instructional focus is in line with Gardner's (2008a) prescription to develop students' expertise in at least one discipline or way of thinking. In addition, brain research and multiple-intelligences theory provide insight into which teaching and learning practices are most effective in helping students learn and retain knowledge, including the use of concept maps in biology. Furthermore, I identified the following two trends in science education: the shift to an active learning approach and the use of frequent classroom assessment techniques. In order to improve students' cognitive skills, I also made their attitudes and motivation to learn a priority. This latter goal depends on my own attitude and time management strategies as an instructor given that my students are the beneficiaries of my work-related morale and feelings of self-efficacy.

### The Original and Revised Taxonomy of Knowledge

Anderson and Krathwohl (2001) update Bloom's taxonomy to reflect current terminology and research on the brain and learning, both by renaming and reordering the classes and by adding cognitive knowledge to the domain in recognition of the role of metacognition in learning (see Appendix D). Their revision acknowledges the interaction that occurs between the knowledge levels during higher-order learning tasks. The taxonomy sheds light on how I can plan my learning activities and assessments to specifically target students' complex thinking skills.

### Meaningful Understanding

*Understanding* refers to the ability to "construct meaning from instructional messages, including oral, written, and graphic communication" (Anderson & Krathwohl, 2001, p.31). According to the authors, this includes the processes of interpreting, exemplifying, classifying, summarizing, inferring, comparing, and explaining ideas (Anderson & Krathwohl, 2001). Understanding in turn corresponds to Bloom's (1956) *comprehension*, or "understanding of the literal message contained in a communication" (p.89). Although not intended as a prescription of teaching methods, Bloom provides teachers with a tool for choosing strategies which encourage critical thinking over rote memorization and the design of assessments that accurately measure the extent to which outcomes are achieved.

### Higher-order Thinking Skills

In their revision of Bloom (1956), Anderson and Krathwohl (2001) identify *evaluation* and *creation* of original works as the higher-order thinking skills (see Appendix D). Evaluation and creation, which follow *application* and *analysis* as transitional skills bridging lower- and higher-order thinking skills, require the making of "judgments based on criteria and standards" and putting "elements together to form a coherent or functional whole" (p.31). According to Anderson and Krathwohl, the processes involved in evaluating and creating are checking, critiquing, generating, planning, and producing

original works. Critical thinking and problem-solving skills are intentionally omitted because these abilities cut across the knowledge classes (Anderson & Krathwohl, 2001).

#### Long-term Memory, Working Memory, and Short-term Memory

According to Craik and Lockhart (1972, as cited in Rose, Myerson, Roediger, & Hale, 2010), long-term memory corresponds to secondary memory, that is, “memory of the distant past that must be brought back into consciousness by a retrieval process” (p.471). Long-term memory contrasts with primary, or short-term, memory, which “reflects the current contents of consciousness” (p. 471). The concept of working memory represents the interplay occurring between short-term and long-term memory when learning tasks involve more than approximately four chunks.

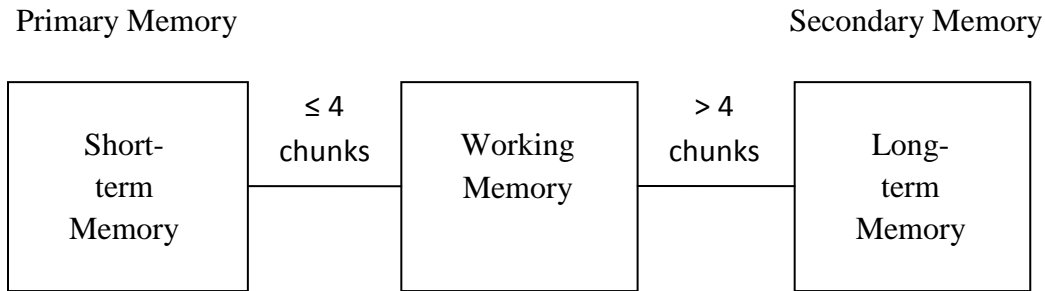

Adapted from recent models in psychology as described by Rose et al. (2010).

Note: A chunk refers to one piece of information such as one vocabulary word.

#### Brain Research

Research shows change in the brain’s organization during learning, evidence that “learning with understanding” requires new instructional approaches to facilitate meaning (Bransford et al., 2000, p.8). Recent brain research has shed light on the understanding of how the brain constructs meaning as novice readers learn. Goswami (2008) states that “a very active area of cognitive neuroscience is the study of which neural structures are active as the brain learns different inputs or performs different tasks” (p.383). Review of correlation-based results obtained using fMRI (functional magnetic resonance imaging) and EEG (electroencephalogram) technology to measure brain activity shows that activation of the visual word-forming area also recruits neurons used in spoken language and picture-naming. These findings support the broad principles underlying “important cumulative effects” (p.388) teachers have in structuring learning environments, namely that: (a) learning is incremental, experience-based, and social; (b) brain plasticity remains throughout life; and (c) multi-sensory input produces “stronger learning” (p.389). Goswami (2008) defines stronger learning as “represented across a greater network of neurons connecting a greater number of different neural structures, and accessible via a greater number of modalities” (p.389).

### Multiple Intelligences Theory

Gardner (2008b) presents the theory of multiple intelligences as a model to describe the various modes in which people learn. He identifies seven intelligences: linguistic, logical-mathematical, musical, spatial, bodily-kinesthetic, interpersonal, and intrapersonal, with recent addition of an eighth naturalistic intelligence (1991, as cited in Bransford et al., 2000). Teachers have applied Gardner's psychological theory by trying to develop each of these intelligences or by focusing on those traditionally undervalued. Gardner's work reveals that students experience the world through a unique set of filters and suggests teachers should select instructional approaches that appeal to a variety of learning styles. However, he cautions teachers against confusing learning styles with intelligences. Gardner (2008b) states that "educators are prone to collapse the terms intelligence and style", but that "style and intelligence are really fundamentally different psychological constructs" (p.2). While style refers to the "customary way in which an individual approaches a range of materials", intelligence refers to the "computational power or potential of an individual's particular neural network" (p.2). An implication of Gardner's work for my project is that students' learning styles, or preferences, while important to consider for reasons such as motivating students and maximizing their enjoyment of learning, are not at all the same as the thought-processing abilities individuals inherit.

### Students' Attitudes and Motivation

According to Bloom (1964), *attitude* is a commonly used term for a range of behaviors involving attending to, responding to, valuing, and conceptualizing a phenomenon, which represent objectives along a continuum of developing interest and motivation by internalizing worth. Bloom maintains that the affective level of *valuing* is "appropriate for many objectives that use the term *attitude*" (p.140). In a science context, Koballa and Crawley (1985, as cited in Rogers & Ford, 1997) define attitude as "a general and enduring positive or negative feeling about science" (p. 3). Allan (1990) defines *motivation* as a factor intended to "stimulate the interest of a person in an activity" (p.773).

### Teacher Attitude

According to Ajzen (2001), attitudes are "dispositions to evaluate psychological objects" (p.29). Given that such objects would include choice of teaching methods and the role of professional development in improving teaching and students' learning, I can reasonably conclude that my attitudes will influence my behavior as a teacher. A key behavior relevant to this project is my willingness to accurately and impartially evaluate, and then adopt, a new teaching approach if the data support my implementation strategy in part or in whole. According to the expectancy-value model, an overall positive or negative attitude about an object develops as we form beliefs consistent with our values, without conscious effort, through the interplay of our feelings (affects) and thoughts (cognition) (Ajzen, 2001). As a mid-career teacher, I already make use of a variety of established

teaching strategies that I have found work for me and many of my students. In addition, I have preconceived notions about my role as a science teacher based on my own experiences as a student who thoroughly enjoyed the transmission-style, chalk-and-talk lectures of the dedicated and inspiring teachers I was exposed to. Awareness of my pre-existing beliefs is especially relevant to my project in light of research findings that people in middle adulthood are least susceptible to attitude change and thus demonstrate the least flexibility of any age group (Visser & Krosnick, 1998, as cited in Ajzen, 2001). In addition, according to Ajzen, because frequency of past behavior tends to predict later actions, I need to be aware of the effects of habitual aspects on my classroom practice. Thinking about and writing down my personal reflections during my project implementation period is one way I can monitor my own attitudes throughout my study. By completing teacher attitude surveys prior to, and regularly throughout, my study, and by reflecting on, and disclosing, my thoughts in a daily journal using both prompts and free writing, I hope to discover, embrace, and ameliorate the effects of personal biases and selective memory on my attitudes during implementation of DI keys. I will also strive to model an attitude of sceptical optimism throughout the course of my study by letting the data and subsequent analysis speak for or against my intervention's effectiveness.

#### Time Management (Instructional Time and Teacher Time)

Kagan (1992) states that instructional tasks “appear to be the vehicles that translate teacher belief into classroom instruction” (p.81). The mismatch between a teacher's beliefs and classroom practice can be influenced by many factors beyond his or her immediate control such as student behavior, resources, course content, and time (Ajzen, 2002, as cited in Mansour, 2008). Consideration of these four factors has led me to conclude that neither student behavior nor resources are constraints in my biology class. On the other hand, real or perceived lack of instructional time, and the worry it causes me over covering the course material, is a major factor affecting my decision to shift to a more constructivist learning model. Mansour (2008) refers to institutional constraints as ‘frames’, or “anything that limits the teaching process and is ... outside the control of the teacher” (p.33). At least one externally imposed time constraint frames my own choice of teaching approach. Although my curriculum articulation body expects me to cover all of the foundational concepts and seven human body systems during the term, my survey of seven other provincial community colleges reveals that they provide from 84 to 120 hours of total instructional time for their equivalent 13- to 15-week introductory biology course; a mean of 105 hours places my 90-hour course at the low end of this range. My dilemma becomes how to best prepare my biology students for their receiving programs, whether by covering as much content in the available time as possible, or by focusing on fewer key concepts and studying them in greater detail. A third option available to me is to achieve a compromise between breadth and depth that maximizes students' learning while minimizing the time stress both I and my students feel to move quickly through the topics.

Time management is an external factor that influences my ability to translate belief into classroom practice. The scant literature available on the relationship between time management and perceived effectiveness in a university context suggests that instructors who have a clear purpose in their careers experience less work-related distress than those who do not. In a small-scale study of academic staff ( $N=59$ ), general staff, and students at a mid-sized Australian research university, Kearns and Gardiner (2007) found a significant positive correlation between use of time-management strategies on the one hand, and both perceived effectiveness and work-related morale on the other, as well as a significant negative correlation with work-related distress. Kearns and Gardiner (2007) collected data from a questionnaire specifically developed for use with the participants in a training course during a staff development unit. Of the four time-management behaviors they assessed (being organized, avoiding distractions, planning and prioritizing, and having a clear goal and purpose), Kearns and Gardiner found having a clear goal and purpose, followed by planning and prioritizing tasks, to be the two most important factors in predicting instructors' (and also notably students') effectiveness. The significance of this study to me as a college instructor is that both my own and students' attitudes are influenced by the degree of alignment between my purpose as an instructor and its translation into classroom practice. By choosing teaching approaches and learning strategies that reflect my own purpose and by modeling learning in a manner that makes the most effective use of the available instructional time, I may be able to reduce my own and students' time stress, as well as improve on the quality of the learning opportunities I create.

APPENDIX D

THE ORIGINAL AND REVISED TAXONOMY OF KNOWLEDGE

BLOOM (1956)	ANDERSON & KRATHWOHL (2001)
Knowledge (simple)	Remember (lowest-order)
Comprehension	Understand
Application	Apply
Analysis	Analyze
Synthesis	Evaluate
Evaluation (complex)	Create (highest-order)

COGNITIVE KNOWLEDGE
Factual (concrete)
Conceptual
Procedural
Metacognitive (abstract)

Note: The original taxonomy by Bloom (1956) divides each of the six knowledge classes into three subclasses, while the revision by Anderson and Krathwohl (2001) includes the concept of metacognition as described by Flavell (1979), thus bringing the total number of subclasses in the cognitive domain to four.

APPENDIX E

ANALOGY ASSESSMENT GUIDE AND RUBRIC

FOCUS	
CONCEPT	Is the biology concept difficult, unfamiliar or abstract?
STUDENT	What ideas do you already have about the biology concept?
ANALOG	Is the comparison something you are familiar with?
ACTION	
LIKES	What features are shared by the analog and the biology concept?
UNLIKES	How is the analog different from the biology concept?
REFLECTION	
CONCLUSION	Is the analogy clear and useful, or confusing?
IMPROVEMENTS	Refocus as above in light of your conclusion.

The FAR Guide created by Treagust et al. (1994, as cited in Venville & Treagust, 1997).

4	3	2	0
Clear and useful	Questionable	Fun	Confusing/missing
a structurally and functionally accurate analogy (textbook potential)	the analogy and target concept share significant similarities and differences	the comparison is a creative simile but lacks relevance to the target concept	the comparison is contradictory or misleading, or no analogy was attempted

Adapted from Angelo & Cross (1993).

APPENDIX F

TEACHER-GENERATED DICHOTOMOUS KEY RUBRIC

RANK			
4	3	2	0
Fully meets or exceeds all expectations	Meets all major criteria but may contain minor inconsistencies or omissions	Minimally meets expectations (contains one major or several minor inconsistencies and/or omissions)	Not handed in or does not meet minimum standards
FORMAT			
vertical or horizontal organization	vertical or horizontal organization	vertical or horizontal organization	GIVENS
contains the specified number ( ___ to ___ ) of concepts, or all concepts provided	contains the specified number ( ___ to ___ ) of concepts, or all concepts provided	contains at least half of the concepts provided	Title
contains the specified minimum of ___ to ___ branching levels	contains the specified minimum of ___ to ___ branching levels	contains at least ___ branching levels	Name
paired lines connect alternate concepts	paired lines connect alternate concepts	paired lines connect alternate concepts	Date
all branching criteria are identified	most branching criteria are identified	at least half of the branching criteria are identified	Neat
			Analogy
			OPTION
			Color
			(limit use)
CONTENT			
all concepts present and accurately depicted; no omissions	most concepts present and accurately depicted; omissions are minor	at least half of the concepts are present and accurately depicted	
all branching criteria are clear and accurate	most branching criteria are clear and accurate	branching criteria may be unclear or missing	
no spelling or grammatical errors	spelling accurate with few/no typos or errors	further editing required	
all concepts are represented by at least three or more of a(n): def'n, example, sketch, analogy, text reference, or word origin	most concepts are represented by one or two of a(n): def'n, example, sketch, analogy, text reference, or word origin	most concepts are represented by one of a(n): def'n, example, sketch, analogy, text reference, or word origin	

APPENDIX G

OBSERVER COMMENT SHEET (ALL UNITS)

Date: \_\_\_\_\_ Unit \_\_\_\_\_

Lesson or Activity –  Lecture  Lab Topic \_\_\_\_\_

Main Objective \_\_\_\_\_

(Above information to be provided by the teacher in advance)

Note: Focus all feedback regarding Treatment Units (2, 3, and 4) on the use of DI keys.

1. Was your impression of students' attitudes toward learning in this lesson *positive*?

Yes, I agree	No, I disagree
Evidence –           Overall Comments	

2. Was your impression of students' motivation to learn during this lesson *negative*?

Yes, I agree	No, I disagree
Evidence –           Overall Comments	



Yes, I agree	No, I disagree
<p>Evidence –</p>          <p>Overall Comments</p>	

Free-form Comments (Use the space below)

Please reflect on students' attitudes and motivation during this lesson in addition to my own attitude and use of instructional time. Is there anything else that you feel would be beneficial for me to know so I can improve my students' learning experiences with my teaching strategies in future lessons?

**PLEASE DO NOT WRITE IN THE SPACE BELOW.**

---

Teacher's comments regarding impact of the observer on student and teacher behavior:

## Definitions and Frames of Reference for Observer

### Attitude

Attitude is a range of behaviors involving attending to, responding to, valuing, and conceptualizing a phenomenon, which represent objectives along a continuum of developing interest and motivation by internalizing worth. Bloom (1964) maintains that the affective level of *valuing* is “appropriate for many objectives that use the term *attitude*” (p.140). According to Ajzen (2001), attitudes are “dispositions to evaluate psychological objects” (p.29). Thus, an attitude is a manifestation of the internal value an individual has ascribed to something.

### Motivation

Allan (1990) defines motivation as a factor intended to “stimulate the interest of a person in an activity” (p.773). Attitude therefore determines whether an individual is motivated to learn or displays interest in a concept.

### Positive (versus Negative)

With respect to attitude and motivation, the individual displays behaviors that demonstrate s/he values a concept or activity, for example, through attentive body language, verbal feedback, and personal involvement in the lesson.

### Effective (versus Ineffective)

The learning activities and teaching approach used achieve the outlined lesson objectives.

### Use of Instructional Time

The directions provided were clear and concise, the number and variety of learning activities was appropriate to the instructional time available and to the group of students present, and the teacher’s specific use of DI keys (if observing a treatment unit) provided all students with the opportunity to actively participate in the lesson.

APPENDIX H

SAMPLE NONTREATMENT LESSON (LECTURE AND LAB)

## Lecture Topic – Organic Compounds: Carbohydrates and Lipids

Materials: molecular models (water, glucose, glycerol, fatty acid), paper half-sheets

The following lesson objectives are included as part of a complete package of course learning outcomes distributed to students on the first day of regular classes:

### Learning Outcomes

- to distinguish between carbohydrates, lipids, proteins, and nucleic acids
- to recognize the empirical formula of a carbohydrate
- to distinguish between monosaccharides, disaccharides, and polysaccharides
- to distinguish between starch, cellulose, and glycogen
- to list the main functions of carbohydrates in the body
- to compare and contrast saturated and unsaturated fats in terms of molecular structure
- to list the functions of lipids (neutral fats, steroids, and phospholipids) in the body

### Introduction/Lesson Starter (5 minutes)

Begin with a chalkboard review of the previous lessons on acids, bases, buffers, and organic compounds (in general). Copy the following concepts onto the board:

$H^+$      $pH > 7$         base    neutralization    hydrocarbon    bra (*blue* → *red with acid*)  
 carbonic anhydrase    acid    ion     $pH < 7$          $pH = 7$         bitter    release  $H^+$   
 $H_2O$      $CO_2$      $H_2CO_3$         rbb (*red* → *blue with base*)     $OH^-$     sour    monomer  
 C forms \_\_\_ (4) covalent bonds        hydrophobic    asymmetrical → \_\_\_\_\_ (*polar*)

A combination of volunteers and selected students identify the correct concept from the example or definition read aloud by the instructor. Each word is circled, checked off, or erased by the instructor or student as it is covered.

### Prior Knowledge (5 minutes)

Give an example of a simple sugar and a complex sugar from your everyday experience.

### Lecture/Direct Instruction (75 minutes)

Notes on Chapter 2: 2.5 Carbohydrates, 2.6 Lipids

Notes are handwritten on the whiteboard and explained in real time and models are passed around the class as each concept is discussed. Oral questions are used to introduce the next subtopic. For example, how are fats and oils different and how are they similar?

### Minute Paper (5 minutes)

Students answer the following two questions anonymously on their paper half-sheets: What is the most important thing you learned today about biomolecules? What do you still want to know about these or other biomolecules? These questions are written on the whiteboard, responses are collected before students leave class, and the results are used to provide feedback at the start of the next lesson.

## Lab: Molecular Model Kits

Name: \_\_\_\_\_

25 marks

The purpose of this lab activity is to help you visualize molecules of life as well as the bonding and chemical reactions that make life processes possible.

Reference: Mader, S. (2011). *Inquiry into Life* (13<sup>th</sup> ed.). New York: McGraw-Hill. Ch 2.

Materials: Allyn & Bacon Molecular Model Kit

Legend:      white = H      red = O      black = C      blue = N

1. Build a water molecule: H<sub>2</sub>O.

Note its bent shape with an interior angle of 104.5°, a consequence of the unequal sharing of electrons between oxygen and two hydrogen atoms. The resulting polar covalent bond gives water all of the unique properties vital to life on Earth.

2. Build a second water molecule and arrange the two water molecules on your desk to show where a hydrogen bond would form between them (imagine as - - -).

Hydrogen bonding gives water its cohesiveness, or ability to stick to itself and other polar molecules. This allows water to be transported up thin tubes in plants from roots to leaves. Hydrogen bonds also hold the A, C, G and T bases in the DNA molecule together.

Before continuing, show your instructor and ask him/her to initial here:

(Now, disassemble.)

3. Build the glucose ring: C<sub>6</sub>H<sub>12</sub>O<sub>6</sub>. Start with the oxygen and form the 5-carbon ring around it. Make sure your glucose molecule has the H and OH groups in the correct up and down pattern around each carbon atom. Use this glucose molecule for step 4.

Glucose is a monosaccharide. It is blood sugar and fuel for the brain.

4. Join forces with another group to demonstrate a condensation synthesis reaction by removing water to form the disaccharide maltose. The summarized word equation is:

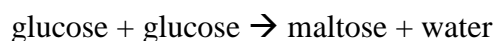

Before continuing, show your instructor and ask him/her to initial here:

(Now, disassemble.)

5. Build a generalized amino acid. Start with the central carbon atom and connect the other four groups to this atom. Note: Use a second white hydrogen to represent the R group. Save this amino acid for step 6.
6. Join forces with another group to demonstrate a condensation synthesis reaction by removing water to form a dipeptide with a peptide bond. The summarized word equation is:

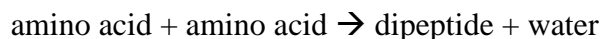

The order of amino acids in a protein is known as its primary level of structure.

Before continuing, show your instructor and ask him/her to initial here:

(Now, disassemble.)

7. Build a glycerol molecule by starting with a 3-carbon hydrocarbon chain and filling in with H and OH as necessary. Save this molecule for step 9.

Glycerol is one of the monomers of neutral fats.

8. Build a 4-carbon fatty acid molecule with or without a double bond. Start with the 4-carbon chain, add the  $-\text{COOH}$  functional group to one end, and fill in the rest of the bonding locations with H atoms. Save this molecule for step 9.

Three fatty acids are required in addition to glycerol to form a neutral fat.

Before continuing, show your instructor and ask him/her to initial here:

(Do not disassemble.)

9. Join forces with other groups and demonstrate the condensation synthesis reaction to form a neutral fat from one glycerol and three fatty acids. Your neutral fat should look somewhat like a capital letter "E".

How many water molecules were released during this reaction? \_\_\_\_\_

What effect does a double bond have on the shape of the molecule?

---

Before continuing, show your instructor and ask him/her to initial here:

### CHALLENGE

Try building lactic acid, the waste product generated by our muscle cells when oxygen is lacking. Lactic acid has the following chemical structure:

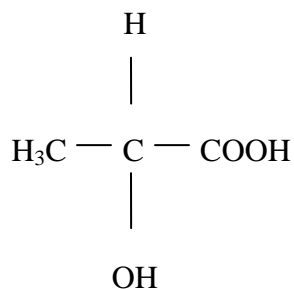

How is lactic acid's structure similar to that of an amino acid, and how is it different?

---

---

Disassemble your remaining model. Check the floor for any dropped connectors and atoms and sort all pieces into their appropriate storage area. Thank you.

(Please hand in this worksheet so your instructor can record your mark.)

APPENDIX I

A TRADITIONAL DICHOTOMOUS KEY FOR IDENTIFYING INSECTS

- 1a. Insect with wings .....2
- 1b. Insect without wings .....7
- 2a. Wings all fully transparent with wings clearly visible .....3
- 2b. Wings not all fully transparent .....10
- 3a. Front and hind wings present .....4
- 3b. Hind wings absent .....Housefly
- 4a. Hind wings about the same size as front wings ..... Dragonfly
- 4b. Hind wings smaller than front wings .....5

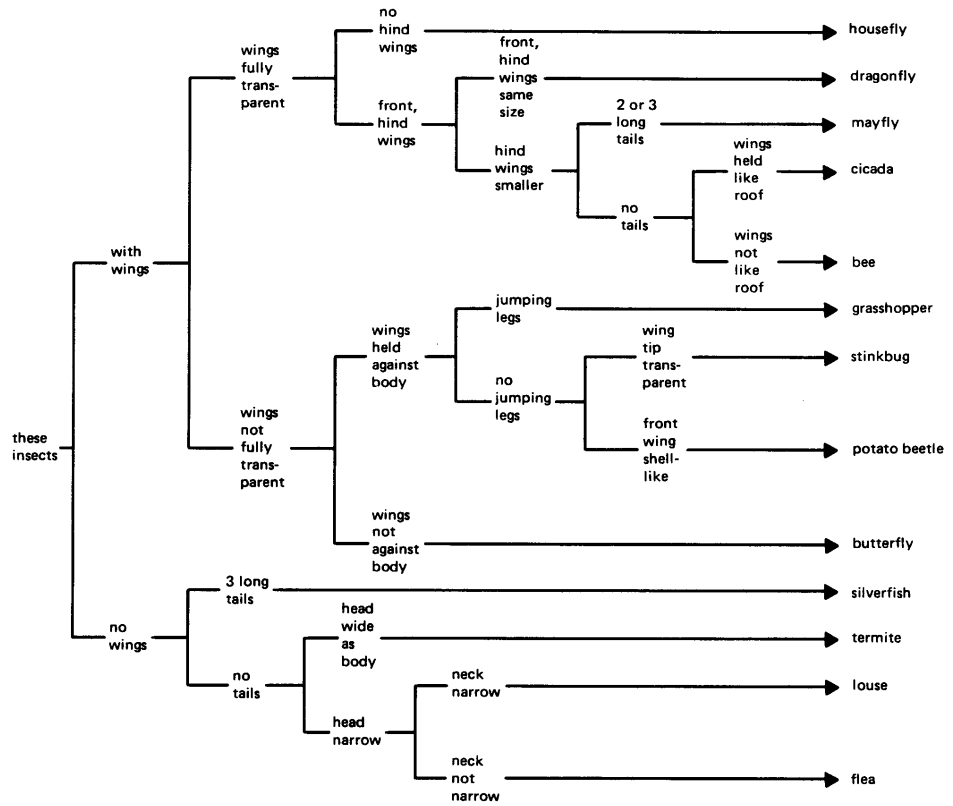

Note: Only enough paired alternate statements have been included in this sample to identify the housefly and dragonfly.

APPENDIX J

VOCABULARY CONCEPT LISTS

Nontreatment Unit (Concept Map)

(No Dichotomous Key)

**biological molecules**

hydrogen

water

inorganic

unsaturated

carbohydrate

ionic

lipid

covalent

protein

polar

RNA

nucleic acid

organic

simple sugar

ATP

nonpolar

amino acid

polypeptide

complex sugar

DNA

saturated

polysaccharide

bonding

helix (25 words)

## Treatment Unit 1 (Concept Map)

**cells**

mitochondrion  
 plasma membrane  
 multicellular  
 animal  
 eukaryotic  
 bacteria  
 plant  
 smooth ER  
 autotrophic  
 chloroplast  
 vacuole  
 protista  
 cell wall  
 unicellular  
 archaea  
 endoplasmic reticulum  
 Golgi apparatus  
 prokaryotic  
 fungi  
 nucleus  
 rough ER  
 heterotrophic  
 organelles (24 words)

## (Practice DI Key on Cells and Organelles)

**cells**

organelles  
 prokaryotes  
 eukaryotes  
 archaea  
 bacteria  
 heterotrophs  
 multicellular  
 protists  
 animals  
 fungi  
 plants  
 structural and control-based organelles  
 cell wall  
 plasma membrane  
 vacuole  
 nucleus  
 nucleolus  
 synthesis/transport/hydrolysis organelles  
 mitochondrion  
 chloroplast  
 ER/rough ER/smooth ER/free ribosomes  
 Golgi apparatus/vesicles/lysosomes

(Dichotomous Key on Membrane Transport)

**membrane transport**

passive

osmosis

diffusion

simple diffusion

facilitated diffusion

active

protein pumps

vesicles

exocytosis

endocytosis

phagocytosis

pinocytosis

coated vesicle (14 words)

(Practice DI Key on Cell Cycle)

**cell cycle**

apoptosis

cell division

somatic cells

interphase

S stage

G stages

G<sub>1</sub> stage

G<sub>2</sub> stage

M stage

mitosis

cytokinesis

meiosis

spermatogenesis

oogenesis

meiosis I

crossing over

independent assortment

meiosis II

## Treatment Unit 2 (Concept Map)

**catalyst**

enzyme

model

lock and key

organic

substrate

induced fit

coenzyme

inorganic

cofactor

product

inhibitor

active site

enzyme-substrate complex

activation energy

denaturation

protein (17 words)

## (Dichotomous Key on Catalysts)

**catalyst**

platinum

enzyme

increase reaction rate

decrease reaction rate

activation energy

limiting factor

substrate(s)

active site

cofactor deficiency

vitamin

mineral

stops reaction

extreme conditions

high temperature

extreme pH

competitive inhibitor

Treatment Unit 3 (Concept Map)

(Dichotomous Key on Metabolism)

**metabolic processes**

No vocabulary word list provided

chloroplast

(DI Key on Feedback Mechanisms)

fermentation

No vocabulary word list provided

aerobic cellular respiration

photosynthesis

stroma

cytoplasm

grana

matrix

mitochondrion

yeast

animal cells

ATP (12 words)

APPENDIX K

COMMENT SHEET FOR (PEER) REVIEW OF DICHOTOMOUS KEYS

Owner's(s') Name(s): \_\_\_\_\_, \_\_\_\_\_

1<sup>st</sup> Group's Comments (Names: \_\_\_\_\_, \_\_\_\_\_)

Strength(s) (use the rubric to identify a minimum of one) –

Suggestion(s) (use the rubric to identify a minimum of one) –

2<sup>nd</sup> Group's Comments (Names: \_\_\_\_\_, \_\_\_\_\_)

Strength(s) (use the rubric to identify a minimum of one) –

Suggestion(s) (use the rubric to identify a minimum of one) –

Instructor's Comments

Strengths –

Suggestions –

APPENDIX L

STUDENT ATTITUDE SCALE (ALL UNITS)

Date Stamp:

Code: \_\_\_\_

## General Preunit and Postunit Questions (Nontreatment and Treatment Units)

Complete the first two questions (1 and 2) by writing your comments in each of the spaces provided. Please **do not** leave any blanks. Your data will help me improve my teaching, this biology course, and other students' learning, so I would appreciate your honest feedback. Your explanation of each response is especially important to this study.

1. What do I *like* about learning biology? Please briefly explain.
  
2. What do I *dislike* about learning biology? Please briefly explain.

Complete the next two questions (3 and 4) by circling the response for each question that best describes your feelings at this time. Please **do not** leave any blanks or tied responses. Your explanation of each response is especially important to this study.

3. I feel *negative* about biology at this point in time.

Yes, I agree	No, I disagree
--------------	----------------

Please explain your answer:

4. I feel *motivated* to learn (more about) biology at this point in time.

Yes, I agree	No, I disagree
--------------	----------------

Please explain your answer:

5. Is there anything else you think I should know to better understand your feelings about biology as a subject and this biology class in particular, or is there something I should have asked you about but didn't that you want to comment on now? Please briefly explain in the space below.

## Supplementary Postunit Questions (Nontreatment and Treatment Units)

You have been studying the \_\_\_\_\_ for the last two weeks. I would like to know more about this unit from your perspective as a student. Complete this survey by circling the one number for each question that best describes your feelings at this time. Please **do not** leave any blanks or tied responses. Your data will help me improve my teaching, this biology course, and other students' learning, so I would appreciate your honest feedback. Your explanation of each response is especially important to this study.

**Note: For the next nine questions (6 to 14), please consider only the activities we did in class other than (ie. not including) dichotomous keys with analogies.**

## Understanding

6. The material and activities in this unit made it *more difficult* for me to understand the vocabulary words I was expected to learn.

Yes, I agree	No, I disagree
--------------	----------------

Please explain your answer:

7. The material and activities in this unit *did not help* me use the vocabulary correctly.

Yes, I agree	No, I disagree
--------------	----------------

Please explain your answer:

## Long-term Memory

8. The material and activities in this unit *helped* me to retain/remember the concepts I learned.

Yes, I agree	No, I disagree
--------------	----------------

Please explain your answer:

## Higher-order Thinking Skills

9. The material and activities in this unit *helped* me to think about the concepts in more complex ways.

Yes, I agree	No, I disagree
--------------	----------------

Please explain your answer:

#### Attitudes

10. I believe the topics I learned about during this unit *are relevant or important* to my life.

Yes, I agree	No, I disagree
--------------	----------------

Please explain your answer:

11. I *disliked* the lecture activities during this unit.

Yes, I agree	No, I disagree
--------------	----------------

Please explain your answer:

12. I *disliked* the lab activities during this unit.

Yes, I agree	No, I disagree
--------------	----------------

Please explain your answer:

#### Motivation

13. The lecture activities *motivated me* to learn more about biology.

Yes, I agree	No, I disagree
--------------	----------------

Please explain your answer:

14. The lab activities *motivated me* to learn more about biology.

Yes, I agree	No, I disagree
--------------	----------------

Please explain your answer:

**Note: For the next three questions (15 to 17), please consider only the dichotomous key with analogy activities we did in class during this unit (ie. not including any of the other learning activities).**

Dichotomous Keys with Analogies

15. I *like biology more* because of the dichotomous key with analogy activities we did during this unit.

Yes, I agree	No, I disagree
--------------	----------------

Please explain your answer:

16. The dichotomous key and analogy activities during this unit *did not motivate me* to learn about biology.

Yes, I agree	No, I disagree
--------------	----------------

Please explain your answer:

17. Is there anything else you think I should know to better understand your feelings about biology as a subject and this biology class in particular, or is there something I should have asked you about but didn't that you want to comment on now? Please explain.

Note: In order to decrease the effects of an agreement or a disagreement response bias in all of my surveys, I used a table of random values to select approximately half of the survey items for wording in the positive sense (e.g. I like). The remaining statements were then worded in the negative direction (e.g. I dislike). In so doing, I hoped to increase the accuracy of each survey item in eliciting a truthful response from my students instead of appealing to their tendencies to respond in a certain manner.\*

\*Rennie, L. J. (1982). Detecting a response set to Likert-style attitude items with the Rating Model, research note. *Education Research and Perspectives*, 9(1), 114-118. University of Western Australia. Retrieved April 28, 2011, from <http://www.rasch.org/erp9.htm>.

APPENDIX M

PRE, POST, AND DELAYED ASSESSMENT: INTRODUCTION TO BIOLOGY

(NONTREATMENT UNIT)

Date Stamp:

Code: \_\_\_\_

Remember- recognize and recall (LOTS)

1. Identify which of the following statements is least reliable to use when deciding if something is living or nonliving?
  - A. Organisms are able to acquire and transform energy.
  - B. Organisms are able to move.
  - C. Organisms are made up of one or more cells.
  - D. Organisms are able to grow, repair, and develop.

Briefly explain: \_\_\_\_\_

2. Which of the following taxonomic classes includes the greatest variety of species?
  - A. genus
  - B. family
  - C. phylum
  - D. kingdom

Briefly explain: \_\_\_\_\_

3. Which molecules are the building blocks of lipids?
  - A. monosaccharides
  - B. amino acids
  - C. glycerol and fatty acids
  - D. nucleotides

Briefly explain: \_\_\_\_\_

Understand- classify and explain (LOTS)

4. Which list correctly classifies human beings in order from domain to species?

A. eukaryotes, animals, chordates, mammals, primates, hominids, homo, homo sapiens

B. prokaryotes, animals, chordates, mammals, primates, hominids, *Homo*, *Homo sapiens*

C. *Homo sapiens*, *Homo*, hominids, primates, mammals, chordates, animals, eukaryotes

D. eukaryotes, animals, chordates, mammals, primates, hominids, *Homo*, *H. sapiens*

Briefly explain: \_\_\_\_\_

5. Why can we use potatoes as a food source but not wood?\*

\*Mader, Sylvia. (2011). *Inquiry into Life*. 13<sup>th</sup> ed. New York: McGraw Hill.

Apply- execute (HOTS)

6. Read the following facts. Water is *a*) a bent molecule with an interior angle of  $104.5^\circ$ , and *b*) has the chemical formula  $H_2O$ . *c*) A solid line represents the chemical bond between the two hydrogen atoms and a single oxygen atom, and *d*) a dashed line represents a hydrogen bond that forms between a hydrogen atom and oxygen atom of two nearby water molecules. Sketch a hydrogen bond between two adjacent water molecules.
7. An amino acid contains a central carbon atom bonded to a hydrogen atom, an R-group, an amine, and a carboxylic acid group. Sketch and label a generalized amino acid.

Analyze- differentiate

8. What features can be used to distinguish a carbohydrate from a lipid?

Evaluate- critique

9. A student in your biology class tells you that steroids aren't lipids because their chemical structure is different from other lipids. Briefly critique this claim.

Create- produce

10. Create labelled sketches to compare and contrast a protein's secondary alpha helix structure to a DNA molecule.

APPENDIX N

PRE, POST, AND DELAYED ASSESSMENT: CELL STRUCTURE AND FUNCTION

(TREATMENT UNIT 1)

Date Stamp:

Code: \_\_\_\_

Remember- recognize and recall (LOTS)

1. What is the function of mitochondria?
- A. They are the sites of photosynthesis in plants where glucose is produced.
  - B. They modify, package, import, and export substances from cells.
  - C. They produce energy to power many of the chemical reactions in cells.
  - D. They control all cell activities by coding for the proteins in the body.

Briefly explain: \_\_\_\_\_

2. A hypertonic solution has a(n) \_\_\_\_\_ concentration of dissolved solute \_\_\_\_\_ the cell than \_\_\_\_\_.
- A. higher, outside, inside
  - B. lower, outside, inside
  - C. higher, inside, outside
  - D. identical, outside, inside

Briefly explain: \_\_\_\_\_

Understand- classify

3. If the cell(s) of a particular organism has (have) a nucleus, cilia, and lysosomes, which of the following organisms could it be?
- A. *E. coli* bacterium
  - B. mushroom
  - C. broccoli
  - D. *Paramecium*
  - E. human cheek cell

Briefly explain: \_\_\_\_\_

4. Which of the following substances would need to pass through a plasma membrane by facilitated diffusion?
- A. water
  - B. carbon dioxide and oxygen
  - C. glucose and amino acids
  - D. lipids

Briefly explain: \_\_\_\_\_

Apply- execute

5. Place these organelles in the sequence required to synthesize a protein and transport it out of the cell.
- A. nucleus, rough ER, Golgi apparatus, vesicle, plasma membrane
  - B. rough ER, nucleus, Golgi apparatus, plasma membrane, vesicle
  - C. nucleus, smooth ER, Golgi apparatus, vesicle, plasma membrane
  - D. plasma membrane, vesicle, Golgi apparatus, rough ER, nucleus

Briefly explain: \_\_\_\_\_

Analyze- attribute (HOTS)

6. Which characteristics of plant cells help them survive in an environment with drastically changing water levels?
7. How does a channel protein regulate what enters and exits the cell?

Evaluate- check and critique

8. In the 1958 movie *The Blob*, a giant single-celled alien creeps around... attacking and devouring people. Why can't there be a real organism as large as the Blob?\*

\*Mader, Sylvia. (2011). *Inquiry into Life*. 13<sup>th</sup> ed. New York: McGraw Hill.

9. Is the plasma membrane a liquid or a solid? Briefly critique both sides of the argument and then make a decision based on your evidence.

Create- generate

10. Glands in the skin of freshwater fish secrete a slimy layer of mucus that makes their skin waterproof. Based on this information and your understanding of tonicity, write a hypothesis statement to explain the purpose of this mucus layer.

APPENDIX O

PRE, POST, AND DELAYED ASSESSMENT: CELL PROCESSES (TREATMENT  
UNIT 2)

Date Stamp:

Code: \_\_\_\_

Remember- recognize and recall (LOTS)

1. DNA replication occurs during:

- A. interphase.
- B. metaphase.
- C. prophase.
- D. telophase.
- E. anaphase

Briefly explain: \_\_\_\_\_

Understand- classify

2. Which type of cell would divide by meiosis?

- A. skin cell
- B. blood cell
- C. sex cell
- D. nerve cell
- E. muscle cell

Briefly explain: \_\_\_\_\_

3. Most enzymes are \_\_\_\_\_.

- A. nucleic acids
- B. proteins
- C. lipids
- D. carbohydrates
- E. inorganic compounds

Briefly explain: \_\_\_\_\_

## Apply- execute and implement

4. If a dog's body cells have 39 pairs of chromosomes, how many chromosomes in total would be found in a male dog's sperm cells? Assume no mutations occur.
5. An enzyme-catalyzed reaction is being monitored in a research lab. A scientist then decides to stop the reaction without denaturing the enzyme or changing the reaction temperature. What are his or her options?

## Analyze- differentiate (HOTS)

6. From an evolutionary standpoint, why is sexual reproduction advantageous for the continuation of the species?\*

\*Mader, Sylvia. (2011). *Inquiry into Life*. 13<sup>th</sup> ed. New York: McGraw Hill.

7. Distinguish between mitosis and meiosis.

## Evaluate- critique

8. A nurse takes a patient's temperature and records it on the chart as 40°C. From the standpoint of enzyme function, evaluate how her patient's fever could be regarded both as a positive or negative event?
9. Evaluate the following statement: An inhibitor works by denaturing an enzyme.

## Create- produce

10. Riboflavin (Vitamin B<sub>2</sub>) forms part of the coenzymes involved in chemical reactions like burning protein and fat. Write a hypothesis to explain how lack of riboflavin in the diet might result in dermatitis (skin problems), blurred vision, and growth failure.

APPENDIX P

PRE, POST, AND DELAYED ASSESSMENT: METABOLISM AND HOMEOSTASIS

(TREATMENT UNIT 3)

Date Stamp:

Code: \_\_\_\_

Remember- recognize and recall (LOTS)

1. Which reaction of aerobic cellular respiration occurs in the cytoplasm of the cell?
- A. glycolysis
  - B. Calvin cycle
  - C. Kreb's (citric acid) cycle
  - D. electron transport chain
  - E. dark reaction

Briefly explain: \_\_\_\_\_

2. Where do the light reactions take place?
- A. matrix
  - B. stroma
  - C. thylakoid membranes
  - D. stomata
  - E. cristae

Briefly explain: \_\_\_\_\_

3. Which of the following body factors is *not* at its normal homeostatic level?
- A. [blood glucose] 0.1%
  - B. core body temp 38 °C
  - C. [blood Na<sup>+</sup>] 0.9%
  - D. blood pH 7.4
  - E. resting heart rate 70 bpm

Briefly explain: \_\_\_\_\_

Understand- classify and explain

4. Identify the pros and cons of anaerobic respiration in animal cells and yeast cells using the grid below.

Cell Type	Pro	Con
Animal		
Yeast		

5. Define metabolism and briefly explain why it is important as a concept in understanding the human body.

Apply- execute

6. Outline the three steps required to synthesize 36 or 38 ATP molecules from one glucose molecule. Include the names of the processes involved, where they occur, and how many ATPs are produced.

Analyze- differentiate and organize (HOTS)

7. Distinguish between aerobic cellular respiration and fermentation.
8. Using the overall summarized chemical equations, what evidence is there that aerobic cellular respiration and photosynthesis are essentially opposite reactions?

Evaluate- critique

9. Critique the following statement: When compared using black and white electron micrographs, mitochondria and chloroplasts are similar structures in appearance.

Create- produce

10. Create a dichotomous key with approximately three levels to compare the two kinds of feedback mechanisms at work in the body.

APPENDIX Q

(CONCEPT) INTERVIEW QUESTIONS (ALL UNITS)

Date Stamp:

Code: \_\_\_\_

## General Preunit and Postunit Interview Questions (Nontreatment and Treatment Units)

1. What do you like about biology? Please briefly explain.
2. What do you dislike about biology? Please briefly explain.
3. I feel *negative* about biology at this point in time. Respond with one of the following:

Yes, I agree	No, I disagree
--------------	----------------

Please explain your answer:

4. I feel *motivated* to learn (about) biology at this point in time. Respond with one of the following:

Yes, I agree	No, I disagree
--------------	----------------

Please explain your answer:

(Motivation)

5. What specific factors in your life outside of school are motivating you to learn new concepts in biology?
6. What class activities make biology more enjoyable or help engage your interest?
7. Is there anything else you think I should know to better understand your feelings about biology as a subject (and this biology class in particular), or is there something I should have asked you about but didn't that you want to comment on now? Please briefly explain.

## Supplementary Preunit and Postunit Concept Interview Question (All Units)

HOTS

8.

Today you are going to create a hierarchical concept map based on the vocabulary you (will be) learned (learning) during the \_\_\_\_\_ unit. It is important to me that you think aloud while you do this task so I can understand your decision-making process in action. I will give you a list of vocabulary words on individual index cards for you to include in your concept map. Be sure to include your connecting phrases and propositions between the concepts. You may add additional terms. Here are the rest of the guidelines:

a) Rank order your list of concepts by placing the most general concept in the middle or at the top and the more specific concepts around or under this main theme:

Sample Concept Map:

most general concept (main theme) - eating utensils

more specific concepts - fork, spoon, knife, chopsticks

most specific concepts – dinner fork, salad fork, dessert fork, etc

b) As the sample map on the next page shows, begin with up to four of the more general concepts.

c) Try to include as many of the other remaining words as possible with the goal of showing how each concept is related to one or more of the others.

d) Rearrange any concepts to best show their interrelationships. Remove words from your concept map if you are unsure about how and where they fit into the scheme.

e) Sketch your final arrangement on paper and draw lines to show how the terms relate.

f) Identify and add any relevant cross-links (e.g. chopsticks to/from knife).

g) Use carefully-chosen linking words written on or beside each line to correctly describe how the connected concepts are related.

Note: There are many right answers and a good concept map is difficult to create.

Procedures for concept mapping were adapted from Novak and Cañas (2008).

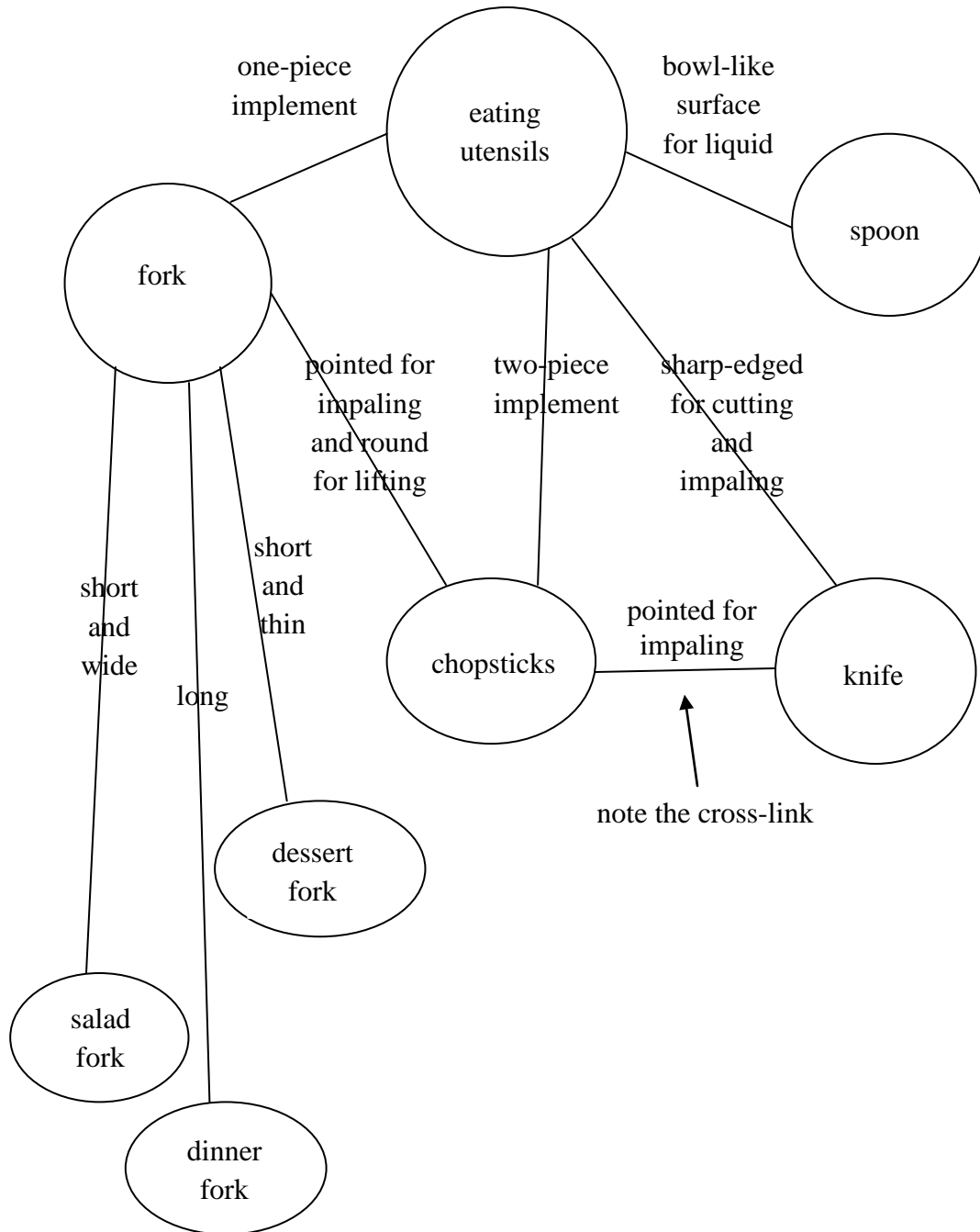

Supplementary Preunit and Postunit Concept Interview Questions (Nontreatment Unit)

Understand- compare and explain)

9. Compare the similarities and differences between prokaryotes and eukaryotes.

10. Define polypeptide and then briefly explain its importance in understanding how the human body works? In other words, what do polypeptides do?

(LTM)

11. Have dichotomous keys with analogies helped you to remember the concepts? Please briefly explain.
12. State the three points of the Cell Theory and list the characteristics that all living things share.

Supplementary Preunit and Postunit Concept Interview Questions (Treatment Units)

(Attitudes)

13. What did you like or dislike about the use of dichotomous keys and analogies with respect to this unit? Please explain.
14. Did the dichotomous keys with analogies or other class materials and activities during this unit make it easier or more difficult for you to learn the concepts? Please explain.
15. Did the class materials and activities during the unit make biology more or less interesting to you? Please explain.

(General)

16. Is there anything else you'd like me to know or is there another question you think I should have asked? Please answer the question you think I should have asked?

Supplementary Preunit and Postunit Concept Interview Questions (Treatment Unit 1)

(LOTS)

(Understand- compare and explain)

17. Compare the similarities and differences between mitochondria and chloroplasts.
18. Define active transport and then briefly explain its role in moving specific substances across the plasma membrane.

(LTM)

19. Have dichotomous keys with analogies helped you to remember the concepts? Please explain.
20. Define the terms fluid-mosaic model and osmosis.

(Attitudes)

21. Was this unit any different from the other unit(s) in terms of your like or dislike of biology? Please explain.

Complete interview with Question 16 and Interview Prompts

Supplementary Preunit and Postunit Concept Interview Questions (Treatment Unit 2)

(LOTS)

(Understand- compare and explain)

17. Compare the similarities and differences between mitosis and meiosis.
18. Define denaturation and briefly explain its importance as a concept in understanding how enzymes work.

(LTM)

20. Define the terms mitosis and enzyme.

Complete interview with Question 16 and Interview Prompts.

Supplementary Preunit and Postunit Concept Interview Questions (Treatment Unit 3)

(Understand- compare and explain)

(LOTS)

17. Compare the similarities and differences between aerobic and anaerobic respiration.
18. Define homeostasis and then briefly explain its importance as a concept in understanding human biology.

(LTM)

20. Define the terms metabolism and negative feedback.

Conclude each interview with Question 16.

Interview Prompts

*Tell me what you mean by...*

*Can you add anything else to that response?*

*Can you give a brief example?*

*Who, What, When, Where, Why, and How?*

APPENDIX R

QUANTITATIVE SCORING RUBRICS FOR CONCEPT-SPECIFIC QUESTIONS

### Marking Rubric for Open-ended Questions

4/4	3/4	2/4	0/4
fully meets or exceeds expectations	partially meets expectations	minimally meets expectations	does not meet minimum expectations
all relevant concepts are identified and the supporting explanation is accurate and complete	all relevant concepts are identified and the supporting explanation is on-target but incomplete	one or all relevant concept(s) is(are) identified but the supporting explanation is unclear, incorrect, or missing	response is off-topic or irrelevant, or no response was attempted

### Multiple-Choice Questions and Concept Maps

Multiple-choice questions were scored out of one point but were deemed correct only if they were accompanied by an explanation that verified the response was a product of the student's knowledge instead of a guess.

Concept maps were scored out of five points using the following holistic quantitative rubric I adapted from Mason (1992, as cited in Doran, Chan, Tamir, & Lenhardt, 2002):

Criteria	Poor 1	Fair 2	Good 3	Very Good 4	Excellent 5
Percentage of Concepts Used					
Concept Hierarchy					
Number of Valid Links					
Concept Cross Links					
Specific Examples					

Number of Concepts: includes all major concepts\*

Concept Relationships: concepts are located logically from general to specific

Number of Valid Links: includes appropriate linking words between concepts

Concept Cross Links: concepts extend in both directions of map

Specific Examples: examples are appropriate if and when included

Note: All answer keys and rubrics were developed or adopted before implementation.

\*Percentage of concepts was quantified as follows by adopting part of a rubric developed by Novak and Gowin (1984, as cited in Doran, Chan, Tamir, & Lenhardt, 2002):

Coverage of Concepts	0-20%	21-40%	41-60%	61-80%	81-100%
Points	1	2	3	4	5

APPENDIX S

TEACHER ATTITUDE SCALE (ALL UNITS)

Unit: \_\_\_\_\_

Date Stamp:

Note: Review the unit-specific student attitude scale, observer's comments, postunit concept interviews, and relevant teaching journal entries before completing this survey.

(Student-centered Questions)

## Understanding

1. The material and activities in this unit *enabled me* to present the vocabulary words in a way that my students could easily understand.

Yes, I agree	No, I disagree
--------------	----------------

Explanation:

## Long-term Memory

2. The material and activities in this unit *enabled me* to teach the biology concepts in a way that helped my students retain the concepts studied in class.

Yes, I agree	No, I disagree
--------------	----------------

Explanation:

## Higher-order Thinking Skills

3. The material and activities in this unit *did not* help my students think about the concepts in more complex ways.

Yes, I agree	No, I disagree
--------------	----------------

Explanation:

## Student Attitudes

4. As a group, I think my students have a *negative* attitude toward this biology unit.

Yes, I agree	No, I disagree
--------------	----------------

Explanation:

## Student Motivation

5. As a group, I believe that I was *unable* to motivate my students to both learn the unit concepts and develop a greater interest in biology.

Yes, I agree	No, I disagree
--------------	----------------

Explanation:

(Teacher-centered Questions)

## Teaching and Attitudes

6. I feel *positive* about this biology unit and that my teaching efforts were *very effective*.

Yes, I agree	No, I disagree
--------------	----------------

Explanation:

7. I feel *positive* about the lecture activities during this unit and that they were *very effective*.

Yes, I agree	No, I disagree
--------------	----------------

Explanation:

8. I feel *negative* about the lab activities during this unit; they were *very ineffective*.

Yes, I agree	No, I disagree
--------------	----------------

Explanation:

## Time Management

9. I was *unable* to teach the unit concepts in the preimplementation timeframe.

Yes, I agree	No, I disagree
--------------	----------------

Explanation:

10. What are my general thoughts about having taught this unit? Explain.

APPENDIX T

JOURNAL PROMPTS

Date:

Lesson or Activity –

“Clearest Point” of lesson –

“Muddiest Point” of lesson –

Feedback from students specific to: conceptual understanding; long-term memory; and higher-order thinking skills –

Student attitude and motivation to learn during lesson –

Impact of this lesson on my teaching –

My attitude regarding this lesson is *positive*.

Yes, I agree	No, I disagree
Explanation –	

My reflections on time management issues (preparation time and instructional time) –

General reflections on today’s lesson (free-writing) –

APPENDIX U

PROJECT TIMELINE

## NONTREATMENT UNIT

January 4: Nontreatment Unit Preunit Concept Assessment  
 January 5/6: Start Nontreatment Unit Preunit Concept Interviews  
 January 7  
 January 11: 1<sup>st</sup> Lecture Observation  
 January 12 (13): 1<sup>st</sup> Lab Observation  
 January 14

## INTERLUDE

January 18: Nontreatment Postunit Assessment; Start Nontreatment Postunit  
 (Non)Concept Interviews  
 January 19/20  
 January 21

## TREATMENT UNIT 1

January 25:  
 Treatment Unit 1 (Non)Concept Survey; Preunit Concept Assessment; Start  
 Preunit Concept Interviews  
 January 26 (27): 2<sup>nd</sup> Lab Observation  
 January 28/29: 2<sup>nd</sup> Lecture Observation  
 February 1: Nontreatment Delayed Concept Assessment; Start Nontreatment Delayed  
 Concept Interviews  
 February 2  
 February 4

## TREATMENT UNIT 2

February 8:  
 Treatment Unit 1 Postunit Concept Assessment; Postunit Concept Survey; Start  
 Postunit Concept Interviews  
 Treatment Unit 2 Preunit Concept Assessment; Preunit Concept Survey; Start  
 Preunit Concept Interviews  
 February 9/10  
 February 11  
 February 15: 3<sup>rd</sup> Lecture Observation  
 February 16 (17): 3<sup>rd</sup> Lab Observation  
 February 18  
 Treatment Unit 1 Delayed Concept Assessment  
 Treatment Unit 2 Postunit Concept Survey  
 Start Treatment Unit 1 Delayed Concept Interviews  
 Start Treatment Unit 2 Postunit Concept Interviews

Feb 21-25 Reading Break (No Classes)

TREATMENT UNIT 3

March 1:

Treatment Unit 2 Postunit Concept Assessment; Postunit Survey; Start Postunit Concept Interviews

Treatment Unit 3 Preunit Concept Assessment; Preunit Concept Survey; Start Preunit Concept Interviews

March 2/3

March 4:

Treatment Unit 2 Delayed Concept Assessment; Start Treatment Unit 2 Delayed Concept Interviews

March 8: 4<sup>th</sup> Lecture Observation

March 9 (10): 4<sup>th</sup> Lab Observation

March 11

March 15: END IMPLEMENTATION

Treatment Unit 3 Postunit Concept Assessment

Treatment Unit 3 (Non)Concept Survey

Start Treatment Unit 3 Postunit (Non)Concept Interviews

March 29:

Treatment Unit 3 Delayed Concept Assessment; Start Treatment Unit 3 Delayed Concept Interviews

APPENDIX V

PREIMPLEMENTATION AND IMPLEMENTATION TIMELINE COMPARISON

Wk	Pre-implementation Term (Fall 2010)	Implementation Term (Winter 2011)
1	Lecture in Lab (Ch 1; Ch 2*)	Lecture in Lab (Ch 1; Ch 2)
	Ch 2 Biochemistry	Ch 2
2	Ch 2	Ch 2
	Molecules of Life	Molecules of Life
	Ch 2	Ch 2
3	Ch 2	Ch 2
	Intro to the Microscope	Intro to the Microscope
	Ch 3 Cells	Ch 2
4	Ch 3	Ch 3
	Plant & Animal Cells	Plant & Animal Cells
	Ch 4 Membrane Transport	Ch 3
5	Ch 4	Ch 4
	Osmosis & Diffusion; Onion Root Mitosis	Osmosis & Diffusion; Onion Root Mitosis
	Ch 4	Ch 4
6	Ch 5 Cell Division	Ch 5
	Enzyme-Substrate Model; DI Keys Intro	Enzyme-Substrate Model
	Ch 6 Enzymes	Ch 6
7	Ch 6	Ch 6
	Dichotomous Key Pilot Review Activity	Dichotomous Key Review Activity
	Ch 6	First Midterm Exam (Chapters 1 to 6)
8	Ch 7 Cellular Respiration	READING BREAK (No Classes)
	Yeast Respiration Demo & Blood Lab	
	First Midterm Exam (Chapters 1 to 6)	
9	Ch 8 Photosynthesis	Ch 7; Ch 8
	Pig Lab 1	Yeast Respiration Demo & Blood Lab
	11.5 Homeostasis	Ch 8; 11.5
10	NO CLASSES (Remembrance Day)	11.5
	Pig Lab 2	Pig Lab 1
	Ch 14 Digestive System	Ch 14

\*Mader, S. (2011). *Inquiry into Life* (13<sup>th</sup> ed.). New York: McGraw-Hill.

Labs



One-week Interlude



Treatment Units



APPENDIX W

ASSUMPTIONS AND LIMITATIONS OF QUANTITATIVE ANALYSIS

### Assumptions

- 1) The level of difficulty of the course content for all four units is equal.
- 2) There is no carryover of knowledge from a prior unit to a subsequent unit.
- 3) Student numbers for the four units will remain constant to optimize paired  $t$ -tests.

### Limitations

- 1) Personal experience and recent random interviewing of students indicates that introductory biology students find certain concepts more difficult than others (2010 data). For example, my students find the biochemistry (Chapter 2) covered in the Nontreatment Unit and tonicity (Chapter 4) covered in Treatment Unit 1 to be difficult concepts. These differences can be minimized through deliberate pairing of a more difficult chapter with a simpler one within all four units. For example, Chapter 2 is paired with Chapter 1 on characteristics of life and taxonomy, while Chapter 4 is paired with Chapter 3 on cells and organelles because chapters 1 and 3 are considered simpler based on prior students' feedback. I also attempted to balance the difficulty of the units by structuring my assessments according to the revised taxonomy (Anderson & Krathwohl, 2001). I developed and/or chose the same number of questions from both the lower- and high-order thinking skills categories for all four units.
- 2) There is always carryover of content from one unit to the next during the teaching and learning process as students build on prior knowledge to understand new concepts. In terms of my unit assessments, I have attempted to minimize the impact of carryover by choosing and wording the concept-specific questions so that students need only use the current unit's knowledge to make a correct response.
- 3) My student numbers may decrease during project implementation due to withdrawals from the course or unexpected circumstances. By eliminating scores when paired data is unavailable, I can maintain the validity of any subsequent paired  $t$ -tests.

### Suggestions for Improvement

I would suggest the following significant improvements to my methodology if I were to repeat my implementation of DI keys in the future. First, I would consult with administration and registration to schedule two separate introductory biology classes of the same course to be offered simultaneously with both the lecture and lab components to be taught by me. Then, I would randomly select one class as the treatment group to receive instruction using DI keys while the other class experiences only my nontreatment teaching methods.

APPENDIX X

QUANTITATIVE DATA ANALYSIS PLAN

## Paired Two-tailed t-tests

where D = Postunit or Delayed Unit, minus Preunit, Percent Difference in Scores

D1 = Nontreatment Unit      D2 = Treatment Unit 1

D3 = Treatment Unit 2      D4 = Treatment Unit 3

Treatment to Nontreatment Comparisons		
	Understanding/HOTS/LOTS	LTM
D1	Post minus Pre	Delayed minus Post
D ( ————— )	D minus D1	D minus D1

HOTS/LOTS = Higher- and Lower-order Thinking Skills, LTM = Long-term Memory

Comparisons Within Units		
	Understanding/HOTS/LOTS	LTM
D1	Post minus Pre	Delayed minus Post
D2	Post minus Pre	Delayed minus Post
D3	Post minus Pre	Delayed minus Post
D4	Post minus Pre	Delayed minus Post

Comparisons Between Units		
	Understanding/HOTS/LOTS	LTM
	Post minus Pre	Delayed minus Post
	D2 minus D1	D2 minus D1
	D3 minus D2	D3 minus D2
	D4 minus D3	D4 minus D3
	D3 minus D1	D3 minus D1
	D4 minus D2	D4 minus D2
	D4 minus D1	D4 minus D1
Plot graph with mean percent difference on the y-axis versus unit of study on the x-axis.		

Chi-square Table (for Yes/No Responses on All Attitude Scales)

	Yes (better)	No (worse)	Total
Postunit Nontreatment	a	b	a+b
Postunit Treatment 3	c	d	c+d
Total	a+c	b+d	$N = a+b+c+d$

Note: This contingency table for chi-square analysis is an example specific to my Student Attitude Scale that I will use to compare students' pretreatment and posttreatment attitudes (see Appendix L).

The lack of fit between observed and expected values will be measured using one degree of freedom. Yates' correction will be used, as  $N$  (the total number of students in my biology class) will likely be less than 30. There is disagreement among statisticians as to when and if Yates' correction should be applied. I chose to use Yates' correction because my chi-square analysis involved both one degree of freedom and the use of a 2x2 contingency table.

APPENDIX Y

SAMPLE CALCULATIONS

## Sample Percent Difference and Percent Change Calculations

N = 20 Student	Individual Score /28		Nontreatment Unit		
	Post Score	Pre Score	% Post	% Pre	% Difference
84	8	1	28.6	3.6	<b>25.0</b>
87	15	3	53.6	10.7	<b>42.9</b>
10	21	6	75.0	21.4	<b>53.6</b>
71	3	1	10.7	3.6	<b>7.1</b>
86	18	5	64.3	17.9	<b>46.4</b>
89	16	1	57.1	3.6	<b>53.6</b>
99	3	0	10.7	0.0	<b>10.7</b>
02	18	3	64.3	10.7	<b>53.6</b>
65	14	4	50.0	14.3	<b>35.7</b>
77	15	4	53.6	14.3	<b>39.3</b>
14	2	5	7.1	17.9	<b>-10.7</b>
30	17	4	60.7	14.3	<b>46.4</b>
61	11	1	39.3	3.6	<b>35.7</b>
62	5	1	17.9	3.6	<b>14.3</b>
59	13	2	46.4	7.1	<b>39.3</b>
69	17	5	60.7	17.9	<b>42.9</b>
40	3	4	10.7	14.3	<b>-3.6</b>
50	11	4	39.3	14.3	<b>25.0</b>
49	7	1	25.0	3.6	<b>21.4</b>
60	6	4	21.4	14.3	<b>7.1</b>
<b>Means</b>	<b>11.2</b>	<b>3.0</b>	<b>39.8</b>	<b>10.5</b>	
			<b>Mean of Percent Differences</b>		<b>29.3%</b>
			<b>Mean of Percent Changes</b>		<b>278%</b>

where Percent Change

=

---



---

## Sample t-test Calculation (Microsoft Excel®)

	<i>Treatment</i>	<i>Nontreatment</i>
	<i>Mean</i>	<i>Mean</i>
Mean	30.478	29.285
Variance	388.5526316	386.6613421
Observations	20	20
Pearson Correlation	0.520276239	
Hypothesized Mean Difference	0	
Df	19	
<b>t Stat</b>	<b>0.28176313</b>	
P(T<=t) one-tail	0.390585571	
t Critical one-tail	1.729132792	
<b>P(T&lt;=t) two-tail</b>	<b>0.781171143</b>	
<b>t Critical two-tail</b>	<b>2.09302405</b>	

**t Stat 0.282 < 2.093 t Crit two-tail**

**not sig**

Rationale for Calculating *t*-tests Using Percent Difference

Hypothetical Student	Raw Scores out of 10 (%)		Percent Change (Post%-Pre%)/Pre%
	Posttest	Pretest	
A	4 (40%)	0 (0%)	(40%-1%)/1% = 39%*
B	7 (70%)	3 (30%)	(70%-30%)/30% = 133%
			<b>Mean Percent Change = 86%</b>
			Percent Difference (%Post-%Pre)
			40%-0% = 40%
			70%-30% = 40%
			<b>Mean Percent Difference = 40%</b>

\*APA Guidelines specify the use of 1% to avoid division by a zero denominator when calculating percent change. Comparing the data using percent difference eliminated the need to alter affected students' preunit assessment scores. In addition, by basing *t*-tests on the percent difference, I was able to minimize the bias I inadvertently introduced by designing assessments worth different numbers of total marks (28, 25, 28, and 31 points, respectively).

## Sample Chi-square Calculation (Yates' Corrected)

Chi-square test      **Long-term Memory**  
 $N = 20$        $df = 1$

Observed			
<b>Table 1</b>	Yes	No	<b>Total</b>
Post-D1	15	5	<b>20</b>
Post-D4	17	3	<b>20</b>
<b>Total</b>	<b>32</b>	<b>8</b>	<b>40</b>

Expected			
<b>Table 2</b>	Yes	No	<b>Total</b>
Post-D1	16	4	<b>20</b>
Post-D4	16	4	<b>20</b>
<b>Total</b>	<b>32</b>	<b>8</b>	<b>40</b>

Yates' Corrected			
<b>Table 3</b>	Yes	No	<b>Total</b>
Post-D1	a=15.5	b=4.5	<b>a+b=20</b>
Post-D4	c=16.5	d=3.5	<b>c+d=20</b>
<b>Total</b>	<b>a+c=32</b>	<b>b+d=8</b>	<b>N=40</b>

$$\sum X^2_{\text{Yates}} = 0.156 < 3.841 \sum X^2_{\text{Stat}} \quad \text{not sig}$$

Step 1: Observed values from the pretreatment and posttreatment attitude scales were entered into Table 1.

Step 2: Hypothetical expected values were entered into Table 2 by multiplying any one cell's column total from Table 1 by the same cell's row total in Table 1, and then dividing by N. For example,  $(32 \times 20) / 40$  gives 16. Table 2 was rebalanced to maintain the original row and column totals shown in boldfaced type.

Step 3: Refer to Table 3. Yates' correction was applied by comparing the observed values in Table 1 to the expected values in Table 2. First, 0.5 was added to the observed cell values in Table 1 that were lower than their corresponding expected values in Table 2 (e.g.  $15 < 16$  so  $15 + 0.5 = 15.5$ ). These corrected values were entered into Table 3. Next, Table 3 was rebalanced to maintain the original row and column totals shown in boldfaced type. The Yates' chi-square statistic was then calculated using the following formula:

---

APPENDIX Z

COMPARISON OF BIOLOGY STUDENTS' MEAN SCORES BETWEEN UNITS  
(UNDERSTANDING AND LONG-TERM MEMORY)

My first comparison of the data between units isolated conceptual understanding, which consisted of analyzing my students' responses to both the lower- and higher-order questions combined. The p-values I obtained for these respective paired two-tailed *t*-tests are summarized in Table 8 as significant or insignificant. A lower p-value indicates a higher level of significance in students' postunit over preunit assessment mean scores.

Table 8

*Comparison of Students' Mean Scores between Units (Understanding), (N = 20)*

Description of Data	Nontreatment	Treatment 1	Treatment 2	Treatment 3
Percent Change (%)	278	263	591	87
Percent Difference (%)	29	28	34	14
Unit	<i>t</i> -statistics			
Nontreatment	-	<i>t</i> = 0.20	<i>t</i> = 0.83	<i>t</i> = 4.34
Treatment 1	-	-	<i>t</i> = 1.20	-
Treatment 2	-	-	-	-
Treatment 3	-	<i>t</i> = 3.35	<i>t</i> = 4.05	-
Unit	Corresponding p-values			
Nontreatment	-	p = 0.84	p = 0.42	p < 0.001
Treatment 1	-	-	p = 0.25	-
Treatment 2	-	-	-	-
Treatment 3	-	p < 0.05	p < 0.001	-

Results indicate no significant difference between students' postunit and preunit assessment mean scores when the first two treatment units ( $M = 28.40\%$ ;  $M = 33.75\%$ ) are each compared to the nontreatment unit ( $M = 29.29\%$ ). Neither was a significant difference found between the first two out of three treatment units when compared to each other ( $M = 28.40\%$ ;  $M = 33.75\%$ ). However, a significant decrease was observed between each of the previous units of study and Treatment Unit 3 ( $M = 14.35\%$ ) (see Table 8). That is, with respect to conceptual understanding, my teaching approach had no discernible impact on the increases observed in the mean scores from the nontreatment unit to the treatment period up to, and including, Treatment Unit 2, but my students' performance during the third and final treatment unit actually deteriorated relative to all preceding units.

The second comparison of the data between units consisted of a similar analysis of my interviewed students' preunit and postunit assessment mean scores across the four units of study taught. These data are separated by achievement category and can be found in Table 9.

Table 9  
*Comparison of Interviewed Students' Mean Scores between Units by Achievement Category (Understanding), (N = 6)*

Description of Data	Nontreatment	Treatment 1	Treatment 2	Treatment 3
High				
Percent Change (%)	84	456	803	30
Percent Difference (%)	32	48	51	16
Middle				
Percent Change (%)	15	412	232	-8
Percent Difference (%)	6	41	42	-4
Low				
Percent Change (%)	100	197	283	56
Percent Difference (%)	36	45	48	28

Results indicate the greatest increase in postunit assessment knowledge occurred from the nontreatment unit to Treatment Unit 1 for students in all three achievement categories. These results suggest that my treatment methods had a positive effect on my low, middle, and high-achieving students' understanding of the biology concepts in first stage of implementation.

The third comparison of the data between units compared my biology students' delayed unit mean scores to their postunit assessment results as a group by pairing the four units with each other in all six combinations. The results of these paired two-tailed *t*-tests are summarized in Table 10.

Table 10  
*Comparison of Students' Mean Scores between Units (Long-Term Memory), (N = 20)*

Description of Data	Nontreatment	Treatment 1	Treatment 2	Treatment 3
Percent Change (%)	-12	14	6	-2
Percent Difference (%)	-5	5	2	-1
Unit	<i>t</i> -statistics			
Nontreatment	-	<i>t</i> = 3.38	<i>t</i> = 1.49	<i>t</i> = 0.92
Treatment 1	-	-	<i>t</i> = 0.72	-
Treatment 2	-	-	-	-
Treatment 3	-	<i>t</i> = 1.96	<i>t</i> = 0.78	-
Unit	Corresponding <i>p</i> -values			
Nontreatment	-	<i>p</i> < 0.05	<i>p</i> = 0.15	<i>p</i> = 0.37
Treatment 1	-	-	<i>p</i> = 0.48	-
Treatment 2	-	-	-	-
Treatment 3	-	<i>p</i> = 0.065	<i>p</i> = 0.44	-

Results indicate a significant increase in students' delayed unit mean scores between the nontreatment unit ( $M = -4.64\%$ ) and Treatment Unit 1 ( $M = 5.40\%$ ),  $t(20) = 3.38$ ,  $p < 0.05$ . These results suggest that my treatment methods also contributed to an improvement in my students' concept retention skills during the earliest stage of implementation.

Similarly, I compared my interviewed students' mean scores on the postunit and delayed unit assessments to isolate any differences in their concept retention across the four units of study. These data are found in Table 11 according to student achievement category.

Table 11

*Comparison of Interviewed Students' Mean Scores between Units by Achievement Category (Long-Term Memory), (N = 6)*

Description of Data	Nontreatment	Treatment 1	Treatment 2	Treatment 3
	High			
Percent Change (%)	-39	7	14	-6
Percent Difference (%)	-29	4	8	-4
	Middle			
Percent Change (%)	-17	7	-17	<b>-27</b>
Percent Difference (%)	-8	4	-10	<b>-13</b>
	Low			
Percent Change (%)	-4	6	-17	-20
Percent Difference (%)	-3	4	-12	-17

*Note.* Boldfaced Type = Data Incomplete (based on only one student)

Results indicate students in all three achievement categories retained, and made gains, in their unit-specific knowledge after Treatment Unit 1, with my high-achieving students continuing to achieve gains through Treatment Unit 2. These data provide further evidence that my treatment teaching approach positively impacted students' long-term memory during the initial stage of implementation.

APPENDIX AA

COMPARISON OF BIOLOGY STUDENTS' MEAN SCORES BETWEEN UNITS  
(LOWER- AND HIGHER-ORDER THINKING SKILLS)

Table 19 displays the results of paired two-tailed *t*-tests used to measure the effects of my treatment teaching methods on biology students' lower-order thinking skills as a group.

Table 19

*Comparison of Students' Mean Scores between Units (Lower-Order Questions), (N = 20)*

Description of Data	Nontreatment	Treatment 1	Treatment 2	Treatment 3
Percent Change (%)	134	950	393	79
Percent Difference (%)	29	57	37	18
Unit	<i>t</i> -statistics			
Nontreatment	-	<i>t</i> = 3.84	<i>t</i> = 1.36	<i>t</i> = 2.00
Treatment 1	-	-	<i>t</i> = 1.88	-
Treatment 2	-	-	-	-
Treatment 3	-	<i>t</i> = 4.96	<i>t</i> = 2.02	-
Unit	Corresponding p-values			
Nontreatment	-	p < 0.01	p = 0.19	p = 0.060
Treatment 1	-	-	p = 0.07	-
Treatment 2	-	-	-	-
Treatment 3	-	p < 0.001	p = 0.058	-

Results indicate a significant increase in my students' mean scores on the lower-order questions from the nontreatment unit (M = 29.38%) to Treatment Unit 1 (M = 57.00%), and a significant decrease between Treatment Units 1 (M = 57.00%) and 3 (M = 18.00%), respectively,  $t(20) = 3.84$ ,  $p < 0.01$ ;  $t(20) = 4.96$ ,  $p < 0.001$ . These data provide evidence for both: (a) an improvement in students' lower-order thinking skills during the initial stage of implementation due to my treatment teaching methods, and (b) a subsequent decrease in lower-order thinking skills due to subject fatigue.

The second part of this analysis consisted of the same comparisons being drawn between all units of study with respect to my students' performance on the higher-order questions as a group. These data can be found in Table 20.

Table 20

*Comparison of Students' Mean Scores between Units (Higher-Order Questions), (N = 20)*

Description of Data	Nontreatment	Treatment 1	Treatment 2	Treatment 3
Percent Change (%)	663	116	936	106
Percent Difference (%)	32	17	33	11
Unit	<i>t</i> -statistics			
Nontreatment	-	<i>t</i> = 2.70	<i>t</i> = 0.25	<i>t</i> = 4.47
Treatment 1	-	-	<i>t</i> = 2.86	-
Treatment 2	-	-	-	-

Treatment 3	-	$t = 0.83$	$t = 3.83$	-
Unit		Corresponding p-values		
Nontreatment	-	$p < 0.05$	$p = 0.80$	$p < 0.001$
Treatment 1	-	-	$p < 0.01$	-
Treatment 2	-	-	-	-
Treatment 3	-	$p = 0.41$	$p < 0.01$	-

Results indicate a significant decrease in my students' mean scores on the higher-order questions between the nontreatment unit ( $M = 31.50\%$ ) and both Treatment Units 1 ( $M = 16.75\%$ ) and 3 ( $M = 10.94\%$ ), respectively,  $t(20) = 2.70$ ,  $p < 0.05$ ;  $t(20) = 4.47$ ,  $p < 0.001$ . In contrast, no significant difference was observed between the mean scores of the nontreatment unit ( $M = 31.50\%$ ) and Treatment Unit 2 ( $M = 32.75\%$ ),  $t(20) = 0.25$ ,  $p > 0.05$ . If compared alongside the results in Table 19, these data suggest that my treatment teaching methods may have increased my students' lower-order thinking abilities at the expense of their higher-order thinking skills during Treatment Unit 1.

APPENDIX AB

STUDENT-GENERATED DICHOTOMOUS KEYS

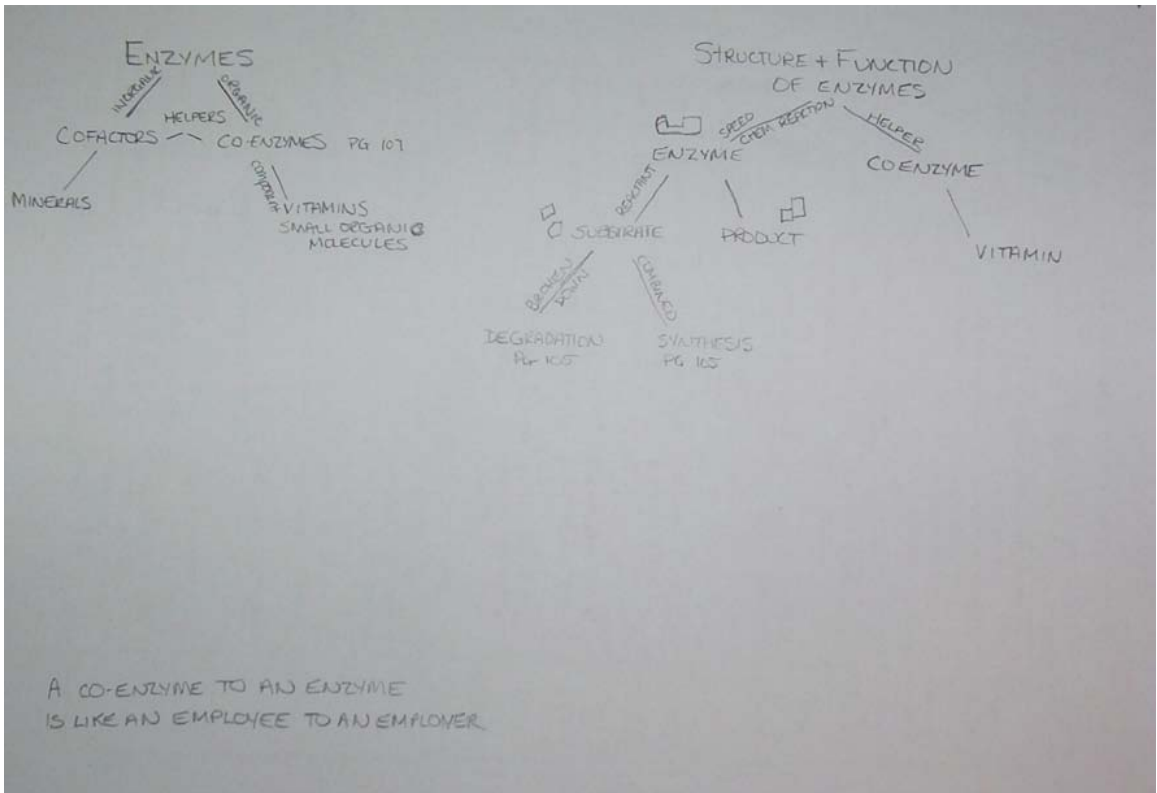
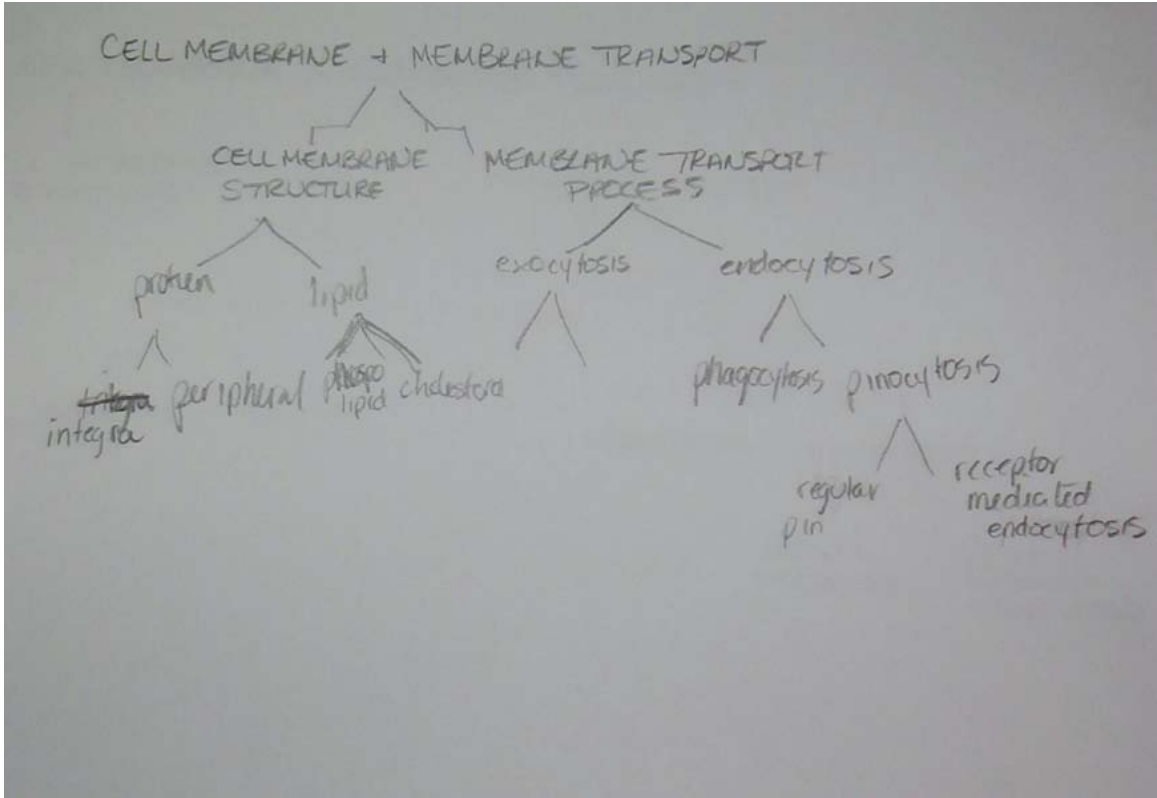

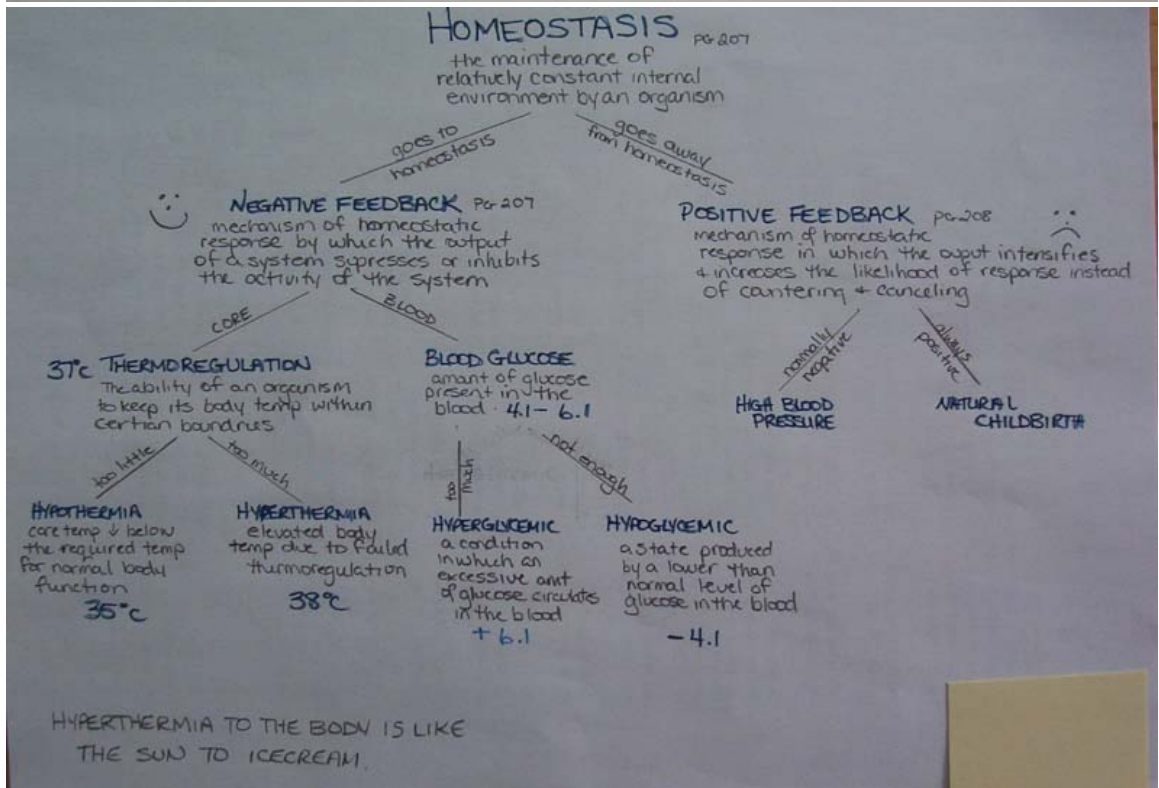
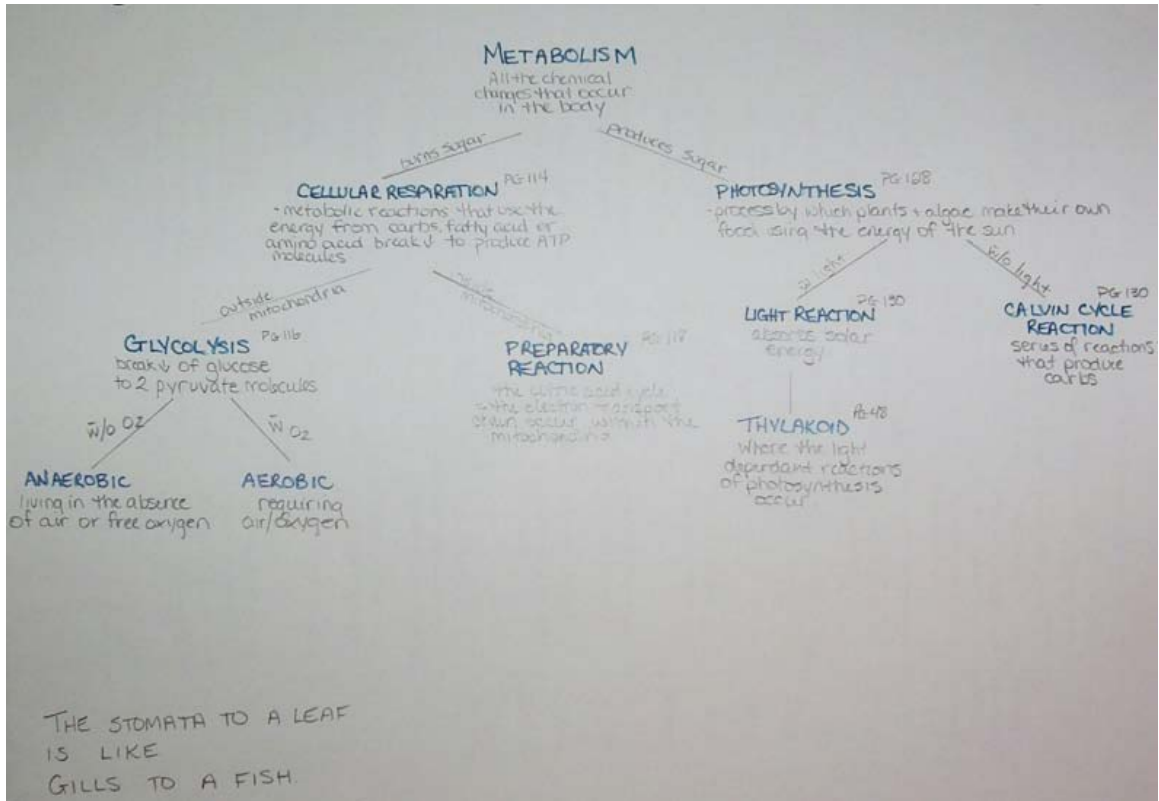

Series 1 (above): Treatment 1, Treatment 2, Treatment 3 (two samples)

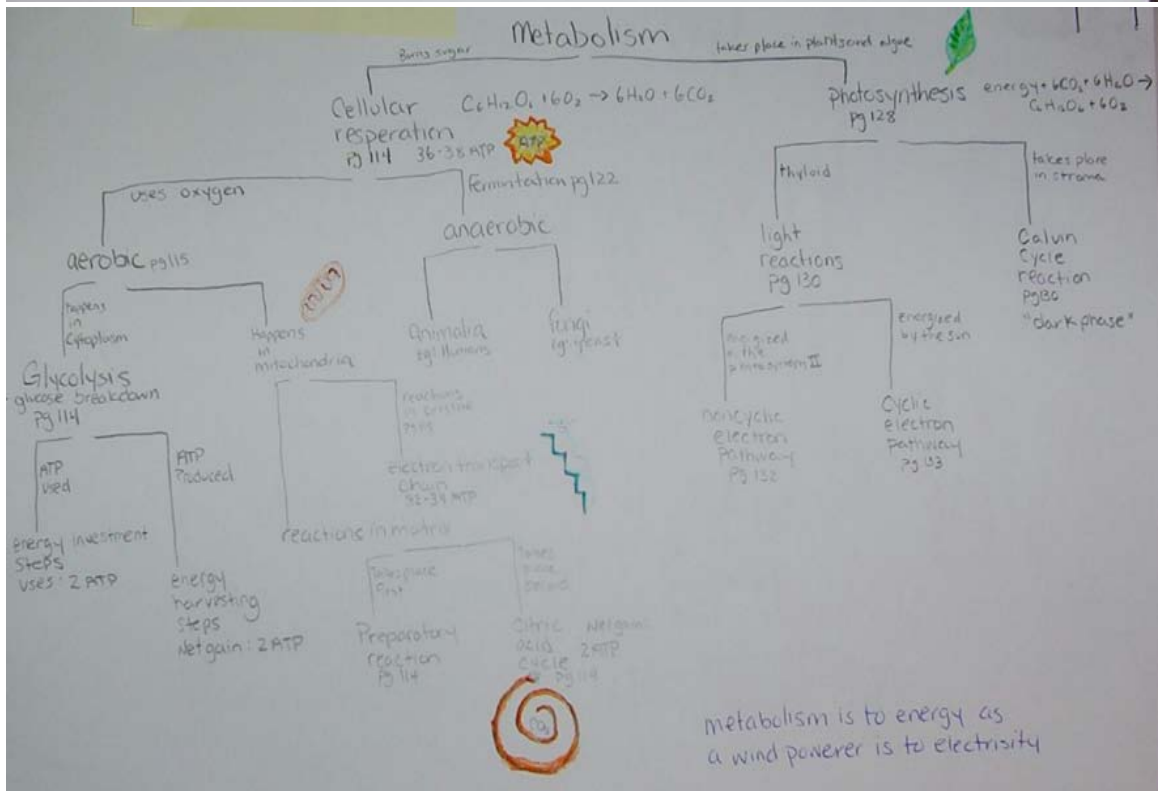
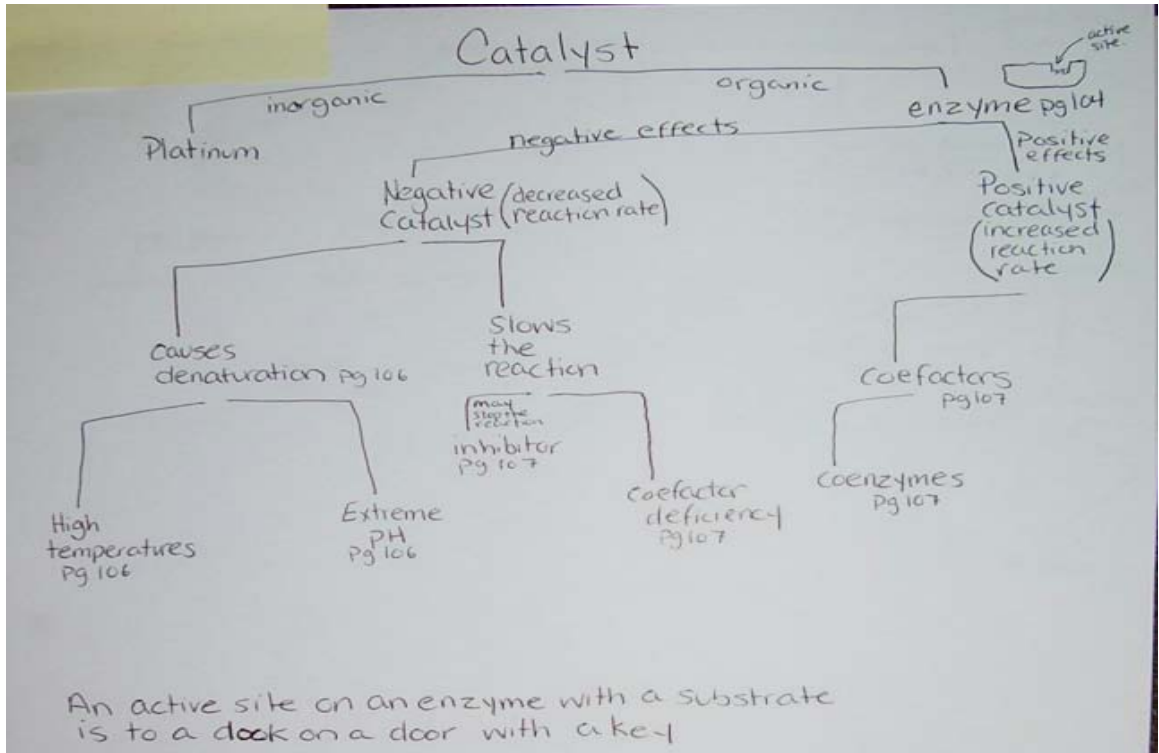

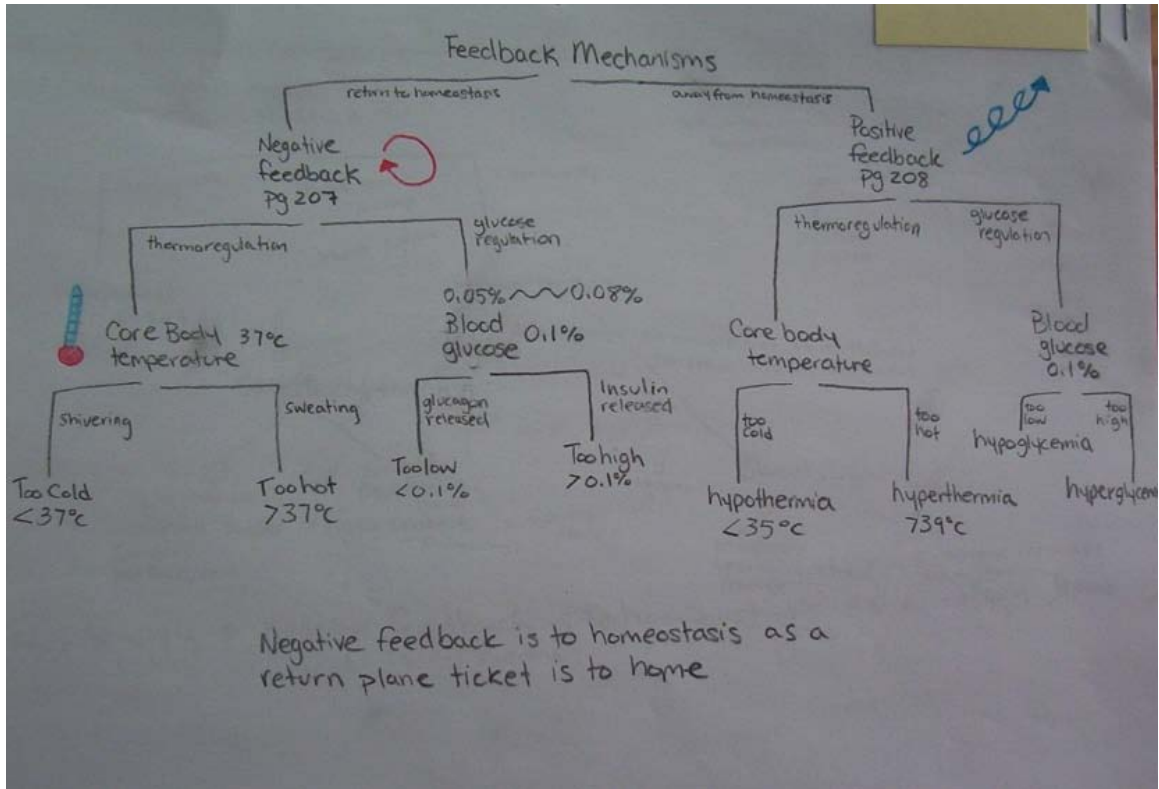

Series 2 Interviewed Student (above): Treatment 2, Treatment 3 (two samples)

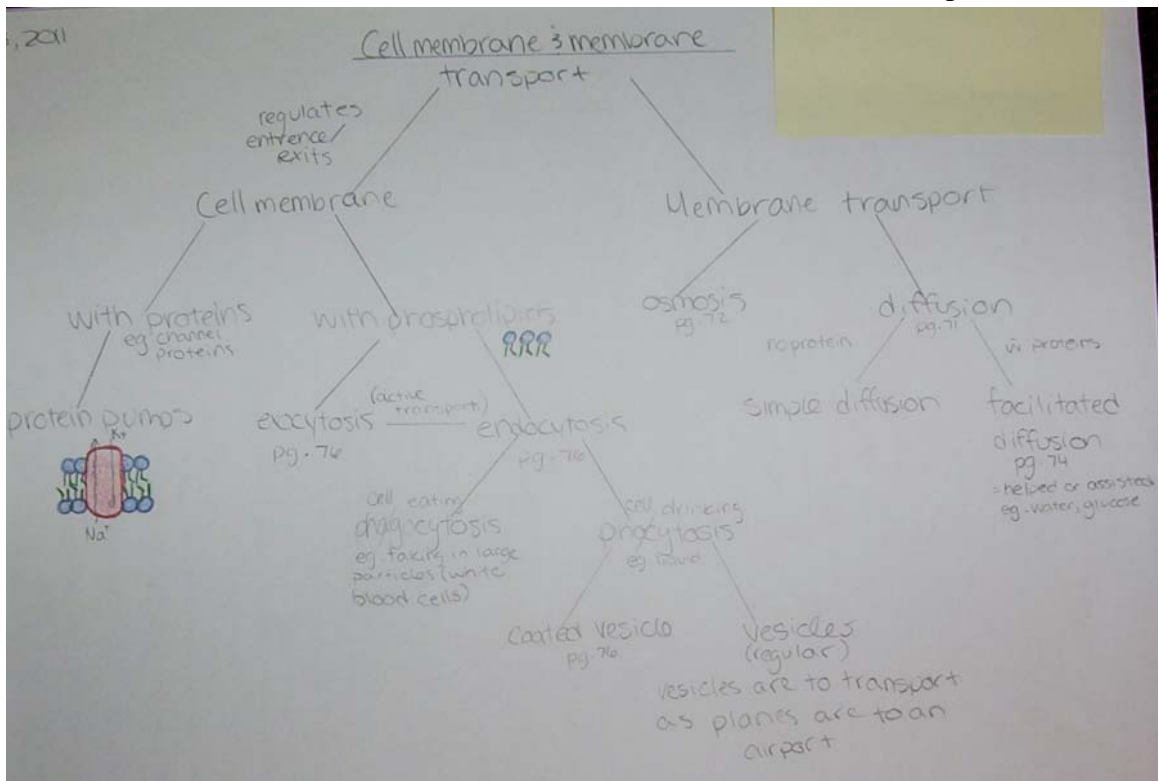

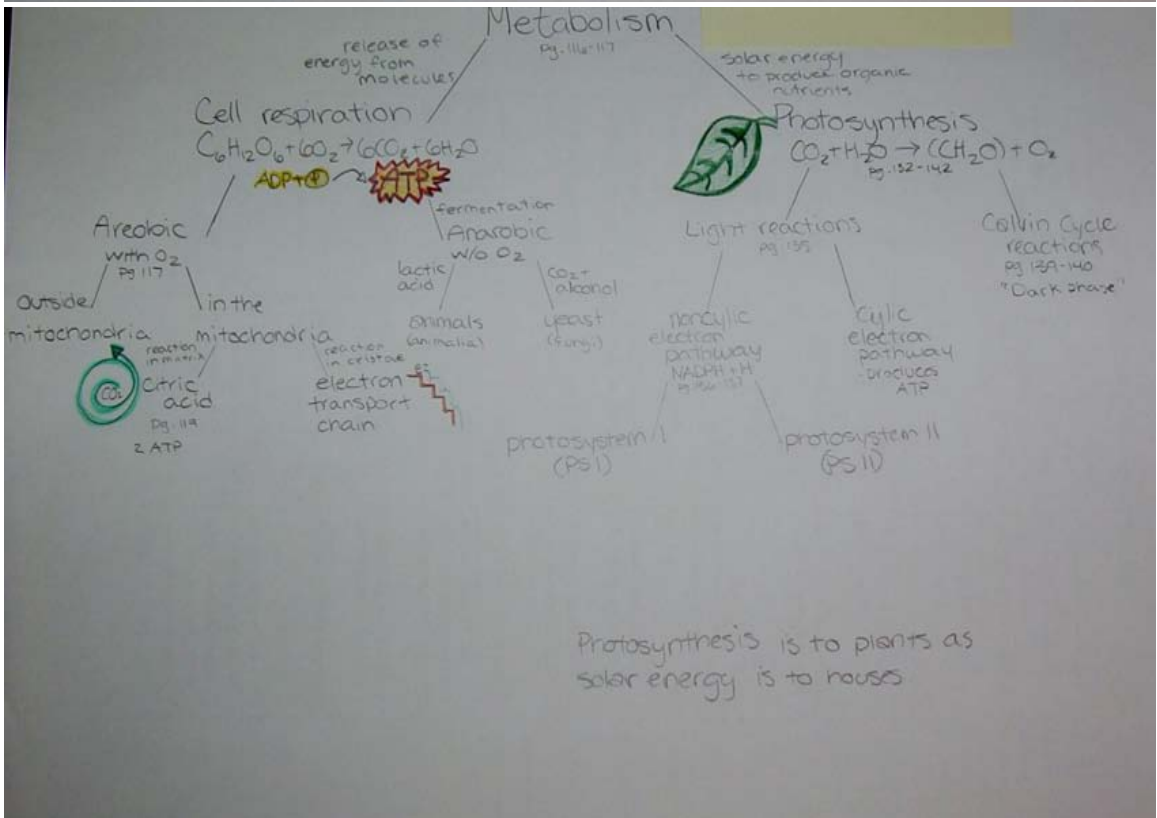
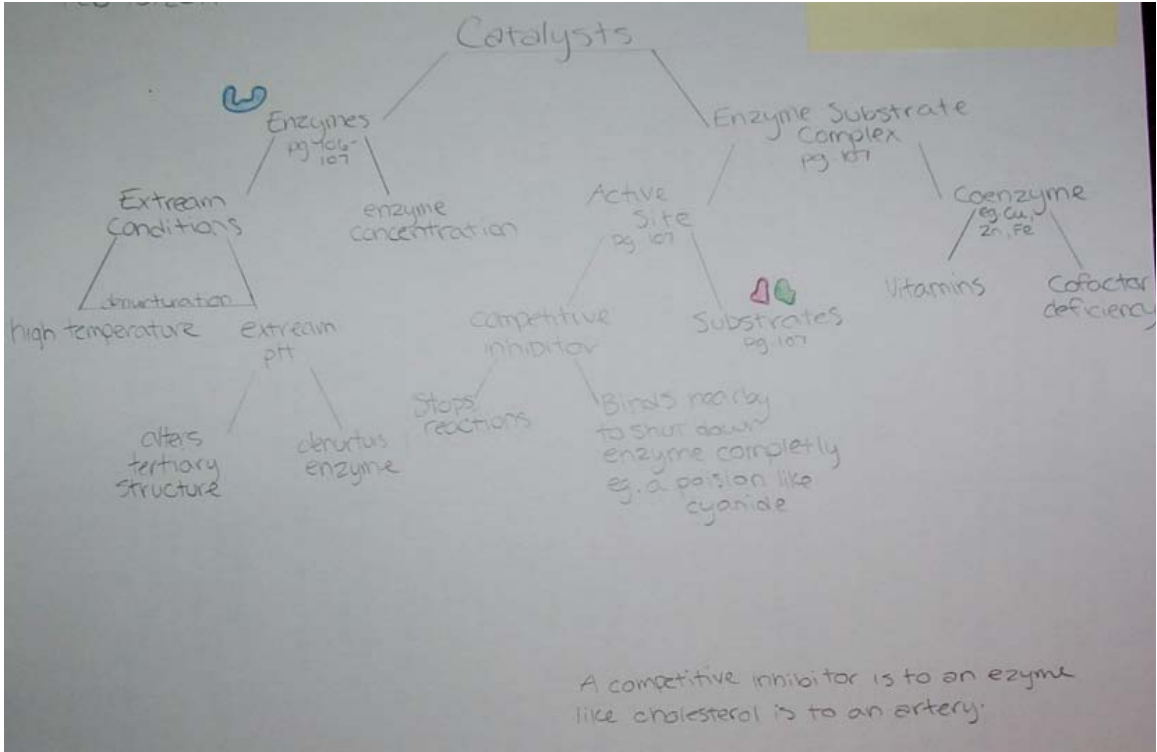

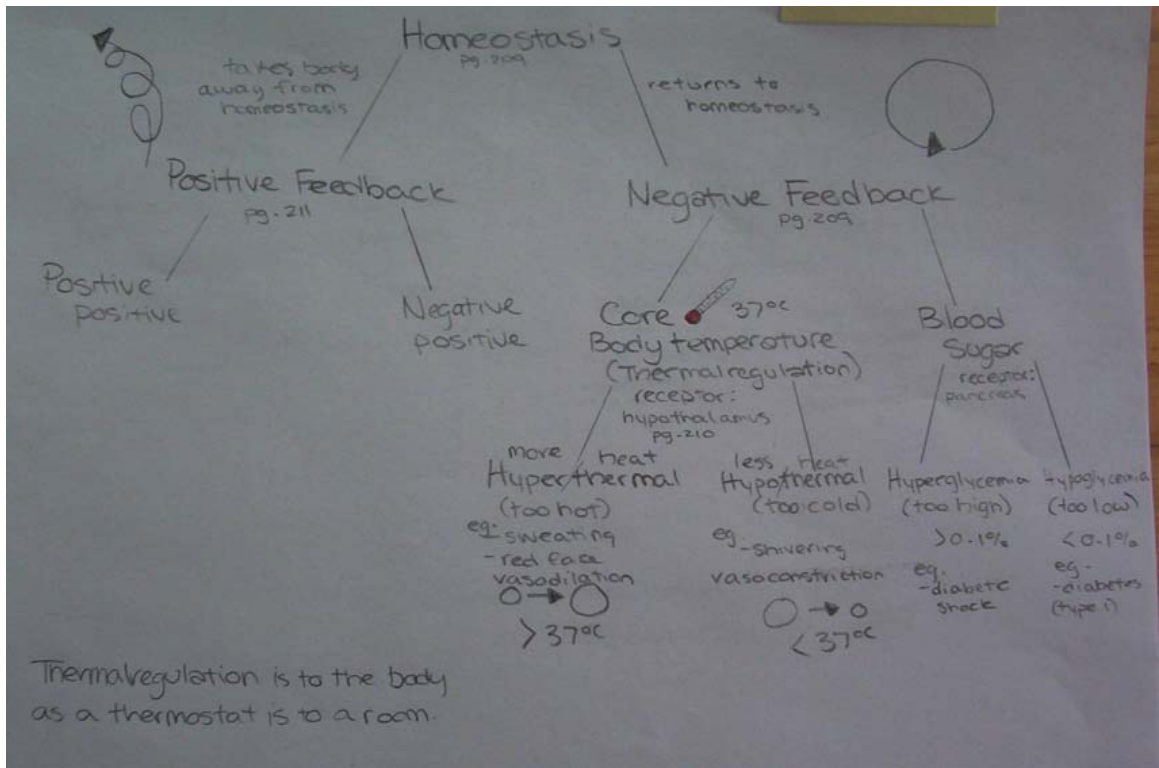

Series 3 Interviewed Student (above): Treatment 1, Treatment 2, Treatment 3 (two samples)

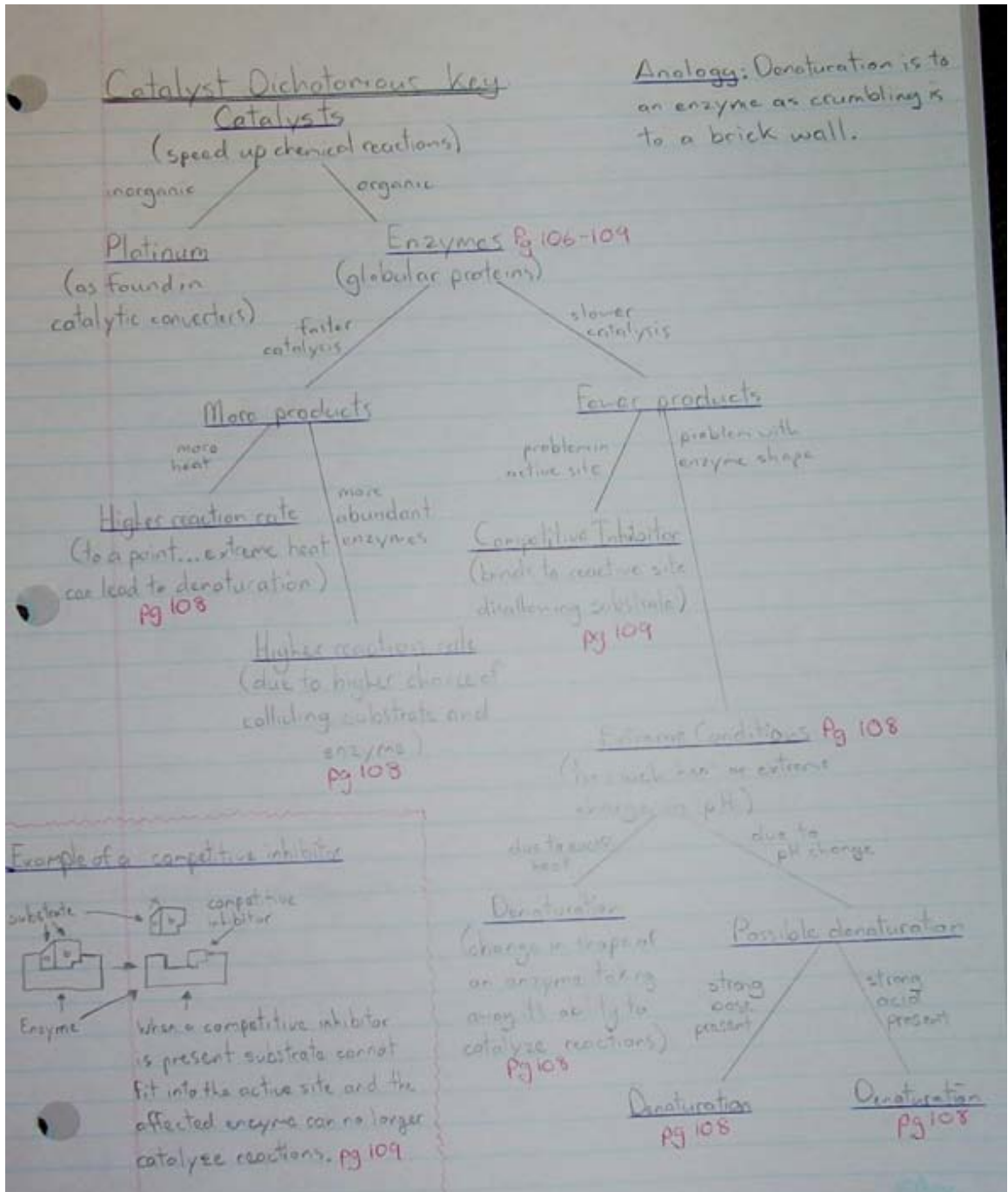

Analogy: Denaturation is to an enzyme as crumbling is to a brick wall.

Example of a competitive inhibitor



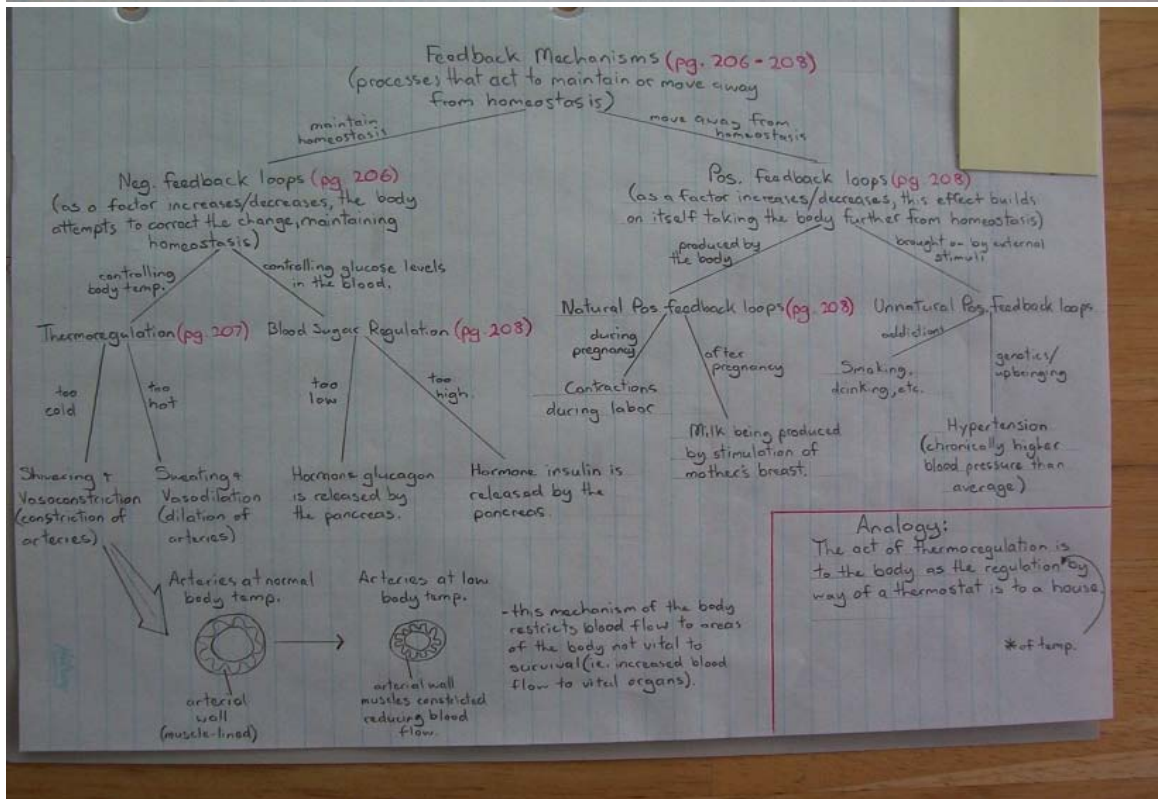
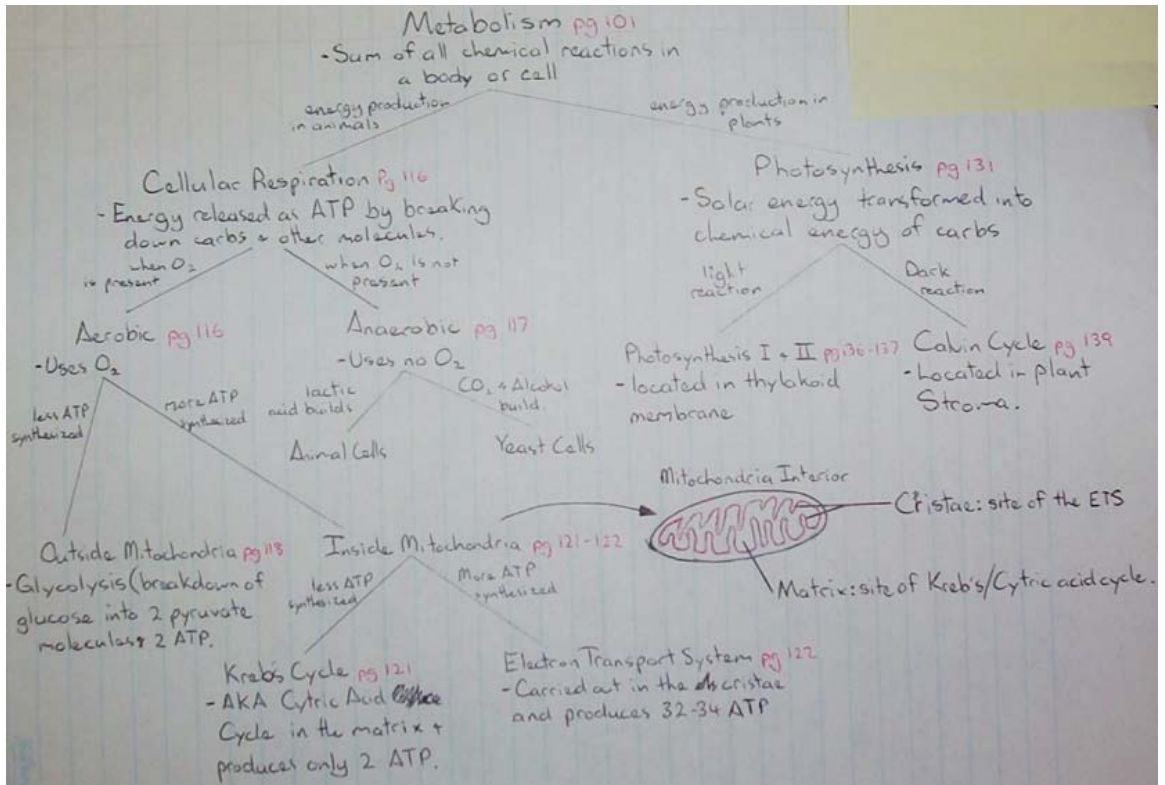

Series 4 (above): Treatment 2, Treatment 3 (two samples)

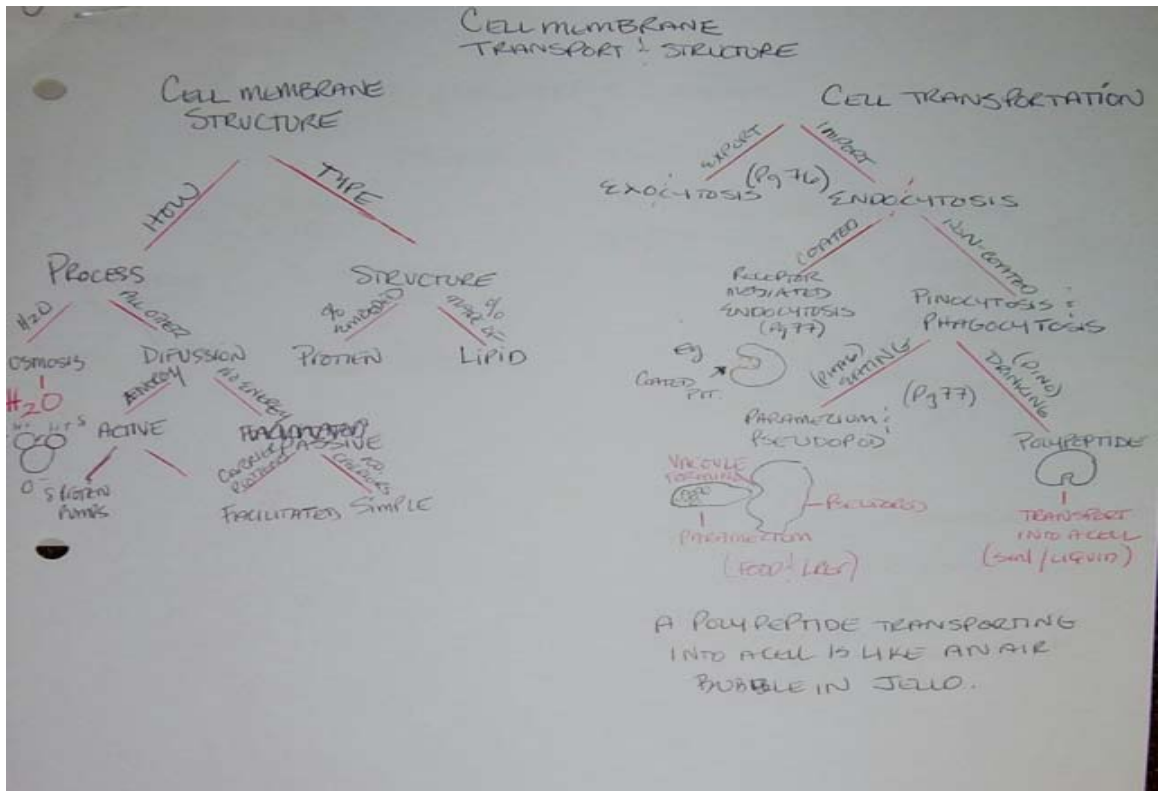

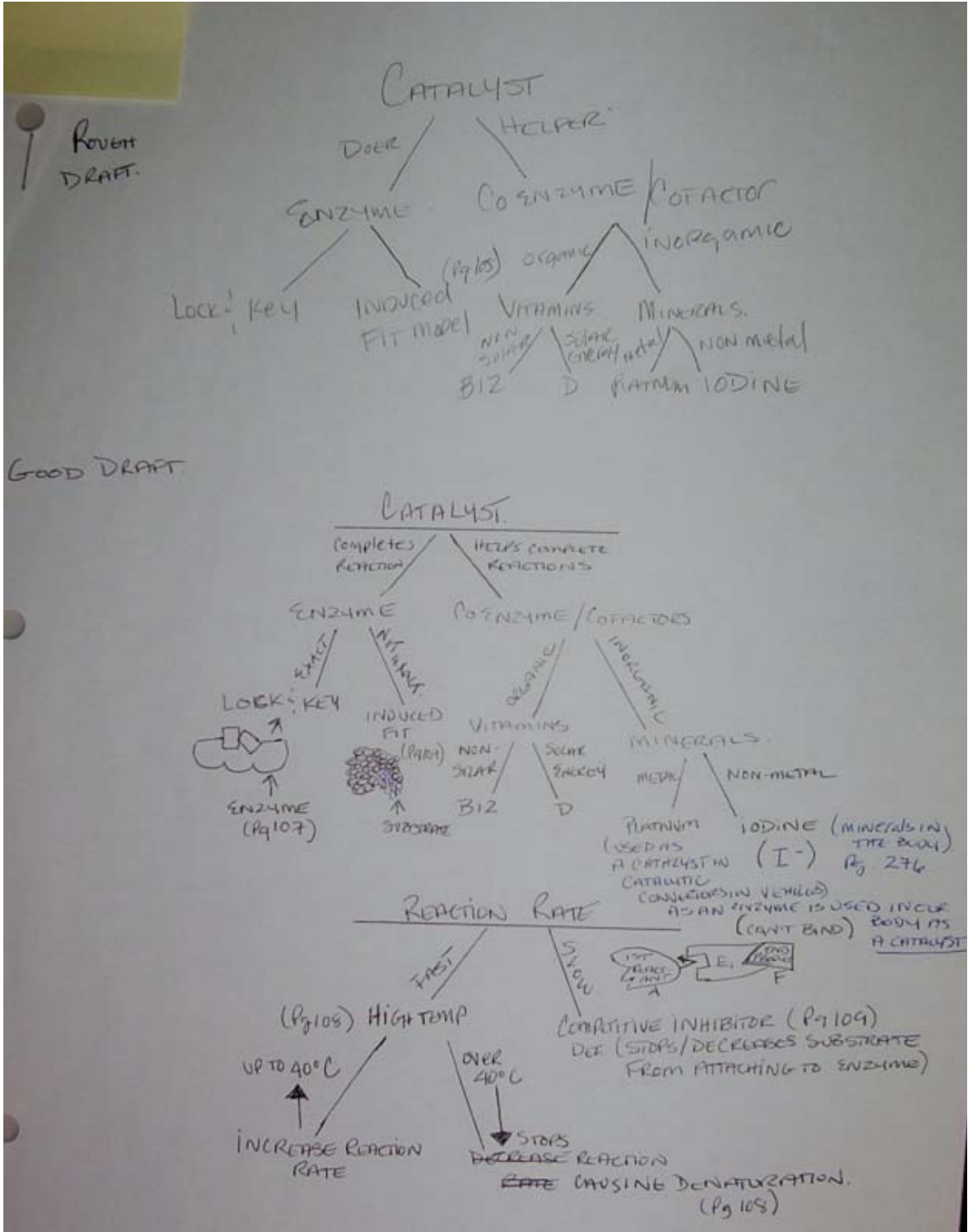

**METABOLIC PROCESSES**

$C_6H_{12}O_6 + 6O_2 \rightarrow 6CO_2 + 6H_2O$

EXERGONIC  
ENERGY OUT

PROCESSES IN WHICH PLANTS AND ALGAE MAKE THEIR OWN FOOD USING ENERGY OF THE SUN

**PHOTOSYNTHESIS (Pg. 134)**

$6CO_2 + 6H_2O \rightarrow C_6H_{12}O_6 + 6O_2$

ENDERGONIC  
ENERGY IN

Metabolic reactions that break down glucose use energy to break into motion breakdown to produce ATP

**CELLULAR RESPIRATION (Pg. 117)**

**CELLULAR RESPIRATION**

Breathing Down / Building Up

GLUCOSE OXIDATION (CATABOLISM)      ATP SYNTHESIS (ANABOLISM)

**CELLULAR RESPIRATION**

Breathing Down / Building Up

GLUCOSE OXIDATION (CATABOLISM)      ATP SYNTHESIS (ANABOLISM)

**CELLULAR RESPIRATION**

THYLAKOID MEMBRANE      STROMA

**LIGHT REACTIONS (Pg. 135)**      **CALVIN CYCLE REACTIONS (Pg. 134)**

Both PSII, I      ONLY PSI

NON CYClic      CYClic

PSII      PSI

PORTION OF LIGHT-DRIVEN REACTIONS OF PS THAT INVOLVES BOTH PSII + PSI MAKES ATP + NADPH (Pg. 136)

PORTION OF LIGHT REACTIONS INVOLVES ONLY PSI MAKES ATP (Pg. 137)

**CALVIN CYCLE**

REDUCING CO<sub>2</sub> REACTION      REGENERATING REGENERATION OF RUBP

I'm stuck now?

ANALOGY: A METABOLIC REACTION IN OUR BODY IS AS AN SMALL DOWNLOAD, ENERGY IS REQUIRED FOR BOTH TO HAPPEN AND THE OUTPUT OR END RESULT ALSO REQUIRES DIRECTION FROM THE MOTHER BOARD TO TO SPEAK ANY SENSE.

Series 5 (above): Treatment 1, Treatment 2, Treatment 3

APPENDIX AC

STUDENTS' POSTTREATMENT COMMENTS ABOUT DICHOTOMOUS KEYS

### Negative Feedback

\*“I liked how this class started out in the first couple of weeks.”

“Dichotomous keys confuse me. I didn’t like how we could only do two branches.”

“They did not help me as a study tool.”

“They frustrated me, so I did not do them.”

“Things got left out and unlearned when dichotomous keys were assigned. I felt negatively towards them because they are based on how that individual feels things should be grouped. Mine would be very different from another’s, and so on.”

“The dichotomous keys did not help me with studying. Mind maps would be better.”

### Neutral Feedback

\*“They got me to open my text, but after the third, they felt a little repetitive.”

### Positive Feedback

“I did enjoy dichotomous keys when vocabulary was included. I struggled with creating my own vocabulary [list].”

“They made me read ahead and know some of the information before class.”

“At first I hated them, but after I got the hang of it, I looked forward to them.”

“It really helped me learn the vocab.”

“They helped to an extent. I’m a notes learner in a way, so the lack of notes did startle me at one point.”

“The dichotomous keys were helpful and fun, but quite time-consuming.”

“Like it [biology] more? No. Understand it more? Probably. In researching vocabulary for the dichotomous keys, more information opened up. They were helpful to pick up the vocabulary (definitions and usage), and the analogies helped to give a reference.”

\*Note: I classified each comment as negative, neutral, or positive based on which of two response options (‘Yes, I agree’ versus ‘No, I disagree’) each student had selected for a specific statement on my posttreatment survey (see Appendix L). Given that half of the questions were worded positively (ie. like) and the others negatively (ie. dislike), my determination also depended on each student’s accurate interpretation of the question. According to my own criteria, the student whose feedback I classified as neutral actually responded positively; I categorized the response as neutral because it was neither as positive nor as negative as the other comments I included in this sample.